

Fitting Instructions #3095IS

Subaru WRX GH

Front Lower Control Arm Rear Bushing

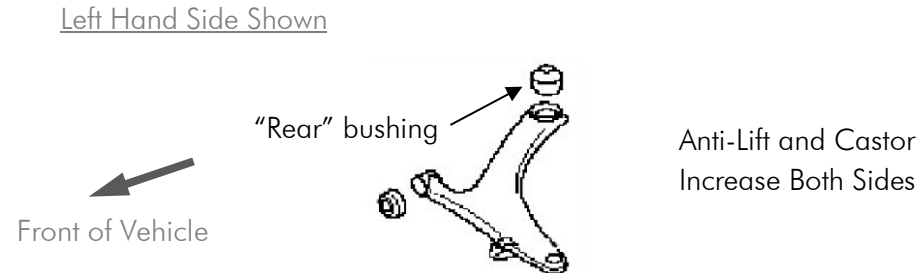

Note: Polyurethane bushes must be fitted to both sides of the vehicle.

- Wheel align the vehicle before the job is started and note castor settings. Remove the control arms from the vehicle;
- Remove original shell part from the control arms with the use of a hydraulic press and suitable pressing tools;
- With reference to the diagrams, align the bushing in the control arms, so that the hole in the bushing is positioned to give the desired castor result;
- Using the grease supplied, generously lubricate the outside of the steel tube, the polyurethane inside of the steel shell parts, and the inside of the polyurethane spacer washers. Push the steel crush tubes into the bushes. A hand press may be required to insert the steel tube, as there can be significant crush;
- Grease the faces of the polyurethane spacer washers, and push them onto the tubes. The spacers are to be arranged as depicted in the diagram below;
- With the use of a 15mm spanner remove the locating pegs from the chassis rail – remove the O.E. alloy spacers and replace them with the 2 larger spacers supplied in this kit, clean the threads then apply thread lock to the upper section of the peg and refit to the chassis rail;
- Refit the control arms with the new bushes and washers into the vehicle. Use the new alloy blue profiled plates to space the bracket to chassis rail, and replace the rear O.E. bolts with the bolts and washers supplied in this kit;
- Wheel align vehicle and check new settings;
- All mounting bolts are to be tightened to manufactures specifications with the vehicle at ride height.

Fitting Instructions #3095IS

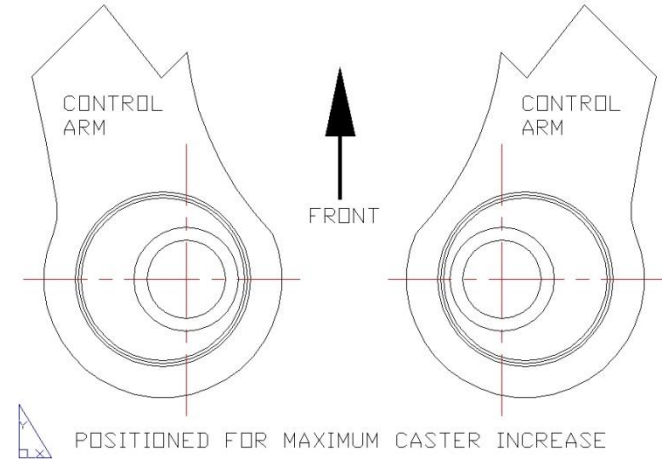

Section View – LHS

