

Instructions

Front Strut Tops - Complete with Caps

NOTE: These components must be fitted by qualified persons only, to factory specifications, as per the factory service manual. Photos are an indication and may vary slightly in appearance from the actual product

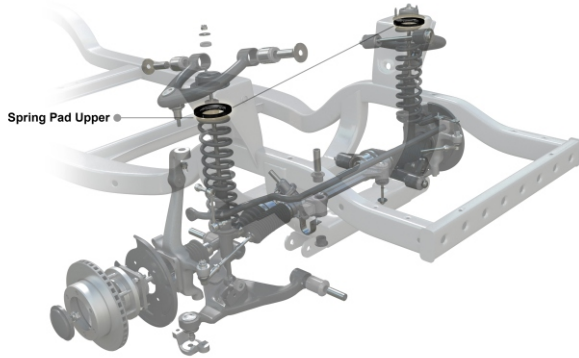

Application - Mitsubishi Pajero NM-NX
- 2000-2022

Always refer complete catalogue listing

Contents - bushing 2994 x1
- bushing 4646 x1
- bushing 4647 x1
- steel top x1
- steel tube 16x10.0x50 x1
- M10 x 1.25 nuts x3
- cupped washer 50x12x4 x1
- shock dust boot x1
- grease

- Raise vehicle evenly and safely support.
Never rely on a jack only
- Proceed to disconnect upper control arm ball joint. Complete removal of the arm may be necessary to remove the strut.
- Next, un-bolt complete strut from vehicle. Note orientation of the 3 (or 4) studs verse the wheel . This will help with re-fitting strut to vehicle. Note below LH image.
- Compress the spring to remove the upper top. Fit up new top with new shock bushings and spring pad. Re-use OE shock shaft dust cover. Re-use OE upper shock nut.

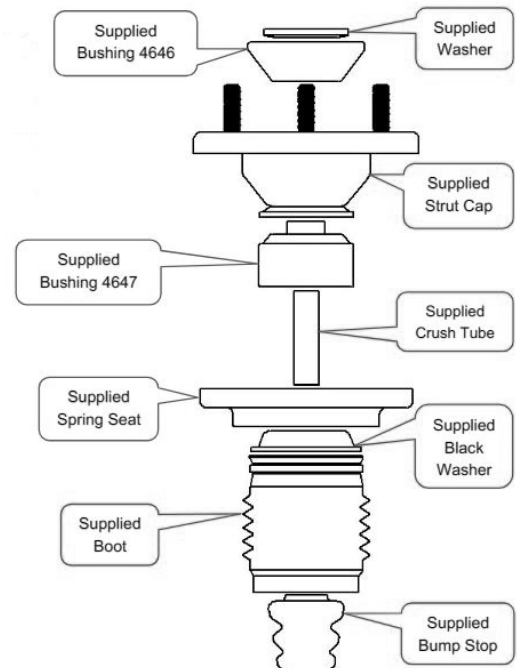
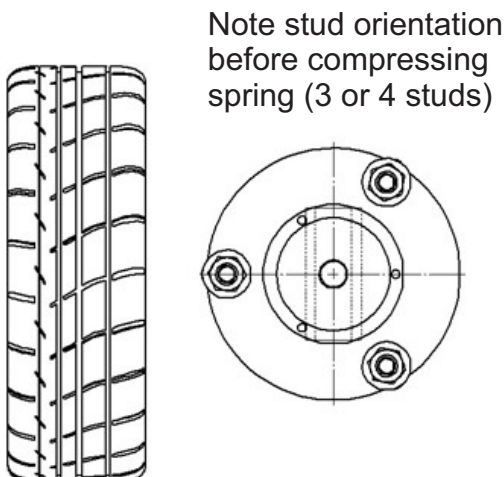

It is recommended that a licenced workshop or trades person carry out the above procedure and that workshop manual and relevant safety procedures are followed in addition to the above.