

Install Guide

Front Upper Control Arms

- Live Adjustable Camber and Caster



Application - Toyota Prado 120 series
 - Toyota Prado 150 Series
 - Toyota FJ Cruiser 2009-on
 - Lexus GX 2009-on

(Always refer current catalogue listing)

Contents - 2x complete upper A arms
 - with adjustable ball joints
 - 4x flat washers
 - grease



WHITELINE recommends checking current tyre wear patterns in addition to noting current wheel alignment settings prior to dismantling.

- Raise vehicle evenly and safely support. Never rely on a jack only.
- Start by removing front wheels.
- Locate the ABS wire. Un-bolt from top side of control arm.
- Next, remove the “R” clip from the ball joint pin.

Refer RH image.

Refer page 2 -

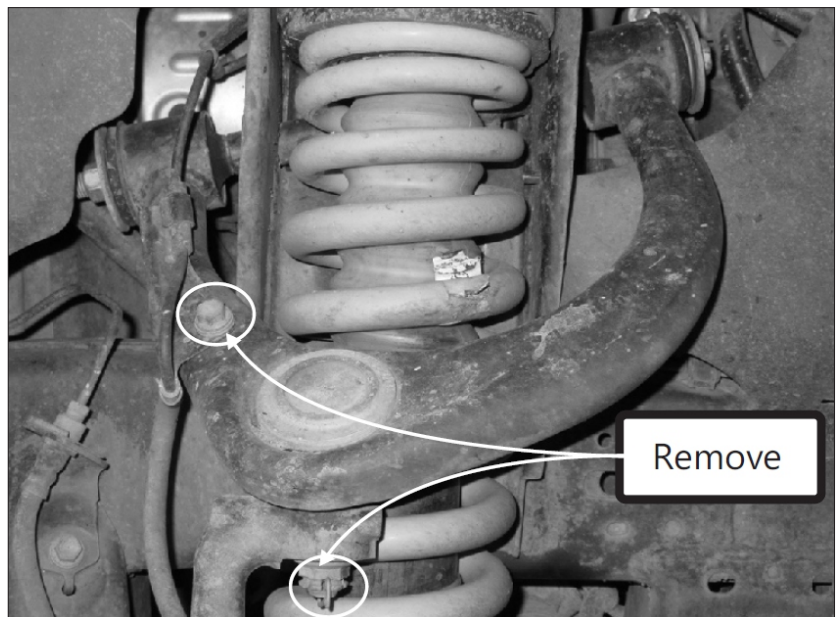

It is recommended that a licenced workshop or tradesperson carry out the above procedure and that workshop manual and relevant safety procedures are followed in addition to the above.

Install Guide

Front Upper Control Arms

- Live Adjustable Camber and Caster

- Next, loosen ball joint nut - but don't remove just yet.
- Strike hub/up-right with hammer to break taper.
- Remove nut and lift arm up.

Refer RH image.

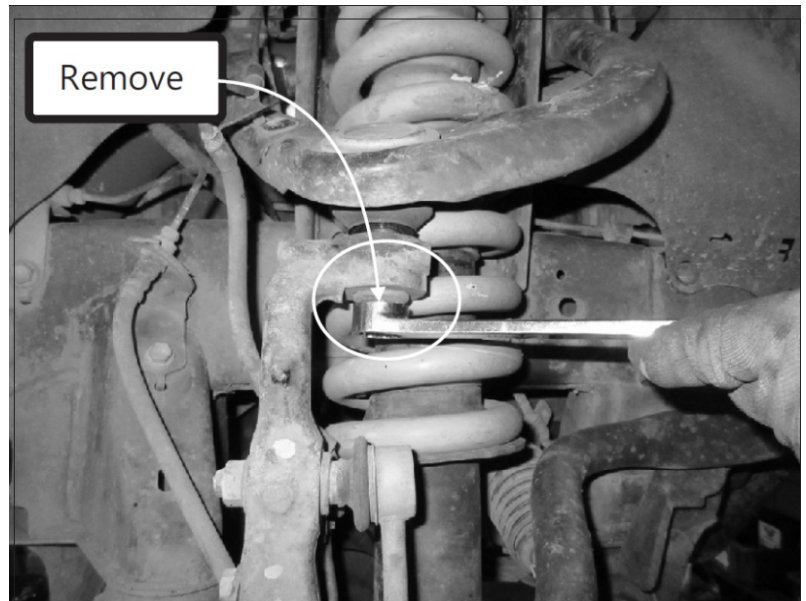

Note - the RH control arm may be challenging to remove without removing some engine bay items. Lift bonnet to review. In some instances, there may be extra batteries.

Also - the A/C pipe next to chassis rail (RHS) may need to be slightly pushed (approx 5-10mm)

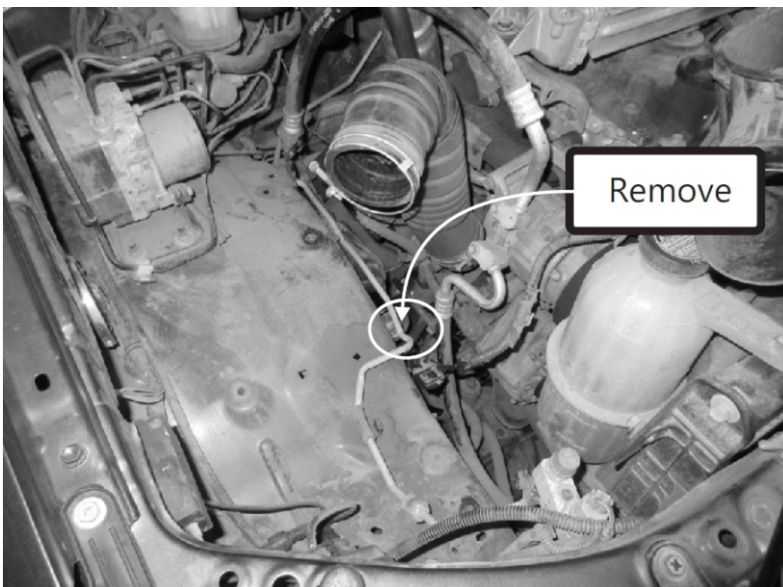

- Remove air mass sensor clip and wiring harness.
- Next, un-bolt air box via the 2 mounting bolts.
- The air filter housing should lift out of the way.

This will make room for the long inner control arm bolt.

Refer LH image.

Refer page 3 -

It is recommended that a licenced workshop or tradesperson carry out the above procedure and that workshop manual and relevant safety procedures are followed in addition to the above.

Install Guide

Front Upper Control Arms

- Live Adjustable Camber and Caster

- Proceed to bolt up new control arms.

Note - grease bushings with supplied grease only.

Also, place the original Toyota outer washer as per the RH image.

- Bolt up new ball joint with new supplied nut and split pin.

Note - the ball joint is pre-set for a desired camber/caster setting for a 40-50mm lift.

Please refer to below and next page for further adjustments.

Tip - the bushing supplied being free spinning offer the ability to tighten the long bolt while the wheels are hanging.

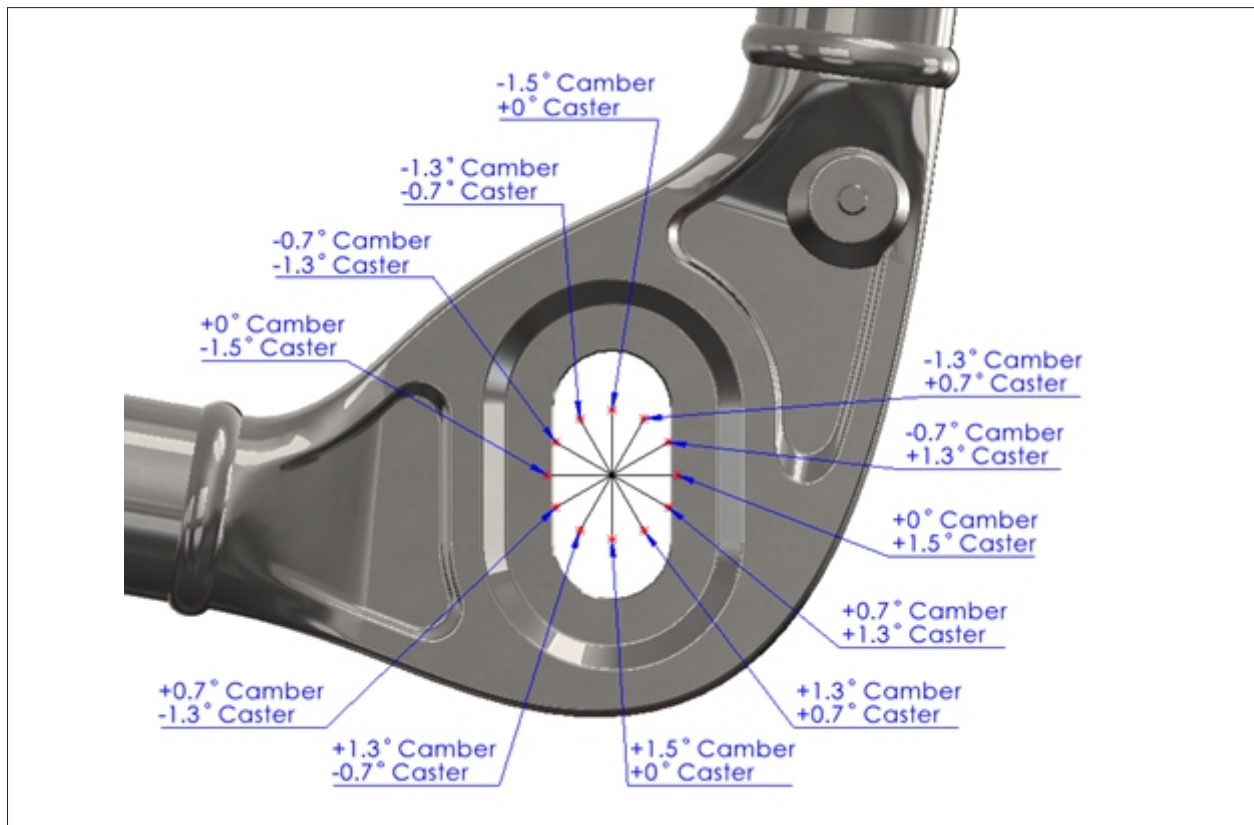
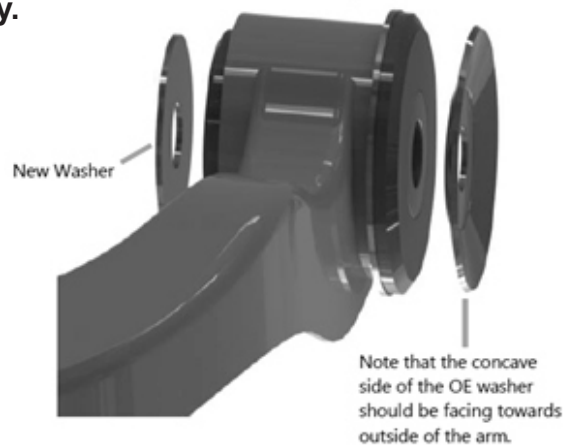

It is recommended that a licenced workshop or tradesperson carry out the above procedure and that workshop manual and relevant safety procedures are followed in addition to the above.

Install Guide

Front Upper Control Arms - Live Adjustable Camber and Caster

WHITELINE adjustable arms offer the ability to fine tune the wheel alignment - to suit vehicles with large tyres, coils and/or if the vehicle is not quite square.

Tip - as a guide, for Toyota 8mm of ball joint movement will offer approx. 1 deg of camber or caster change.

IMPORTANT - the large upper nut must be tensioned to 143Nm.

- Test drive vehicle post wheel alignment.
- Re-check all bolts after 500kms.

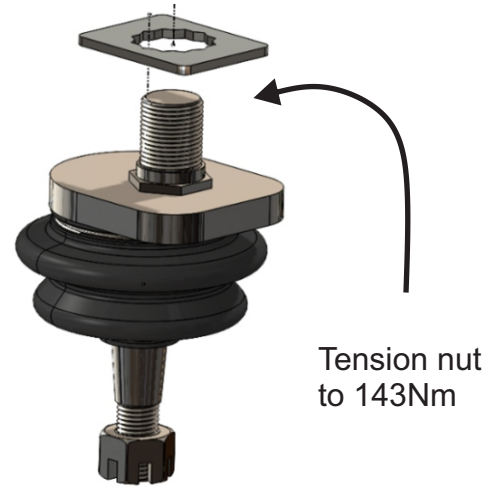

Recommended settings for 50mm lift (2")	Recommended settings for 75mm lift (3")
<p>Position the ball joint pointing straight inwards and slide the ball joint 4mm from the outside.</p>	<p>Position the ball joint to the first position angled rearward and slide the ball joint 7.5mm from the outside.</p>
<p>This configuration roughly equates to the following changes over the OE UCA: Camber: -0.5 deg Caster: +1.8 deg</p>	<p>This configuration roughly equates to the following changes over the OE UCA: Camber: -0.7 deg Caster: +2.6 deg</p>

It is recommended that a licenced workshop or tradesperson carry out the above procedure and that workshop manual and relevant safety procedures are followed in addition to the above.