

# Instructions

## Lower Control Arm Bushings

**N.B:** This instruction sheet should be used in conjunction with the workshop manual and proper safety procedures followed.

1. Raise vehicle evenly and safely support.

**Application:** Holden Colorado RG - on  
Isuzu D-Max MP - on

**Removing old bushings - this is best achieved with a Air-hacksaw and if required, an Oxy.**

**Contents:** 4x bushings with bonded washer  
4x steel tubes  
2x grease

2. The outer steel shell will need to be cut.  
You may wish to heat up the inner steel tube and remove this prior to cutting the rubber and outer steel shell.

**Note - make the cut near the welded side of eyelet.**

3. Once bushings removed - clean eyelets.

4. Push supplied bushings in from outside in - refer image below. Grease bushing ID and face.

5. Tighten bolts to Manufacturers specs, then carry out a wheel alignment.

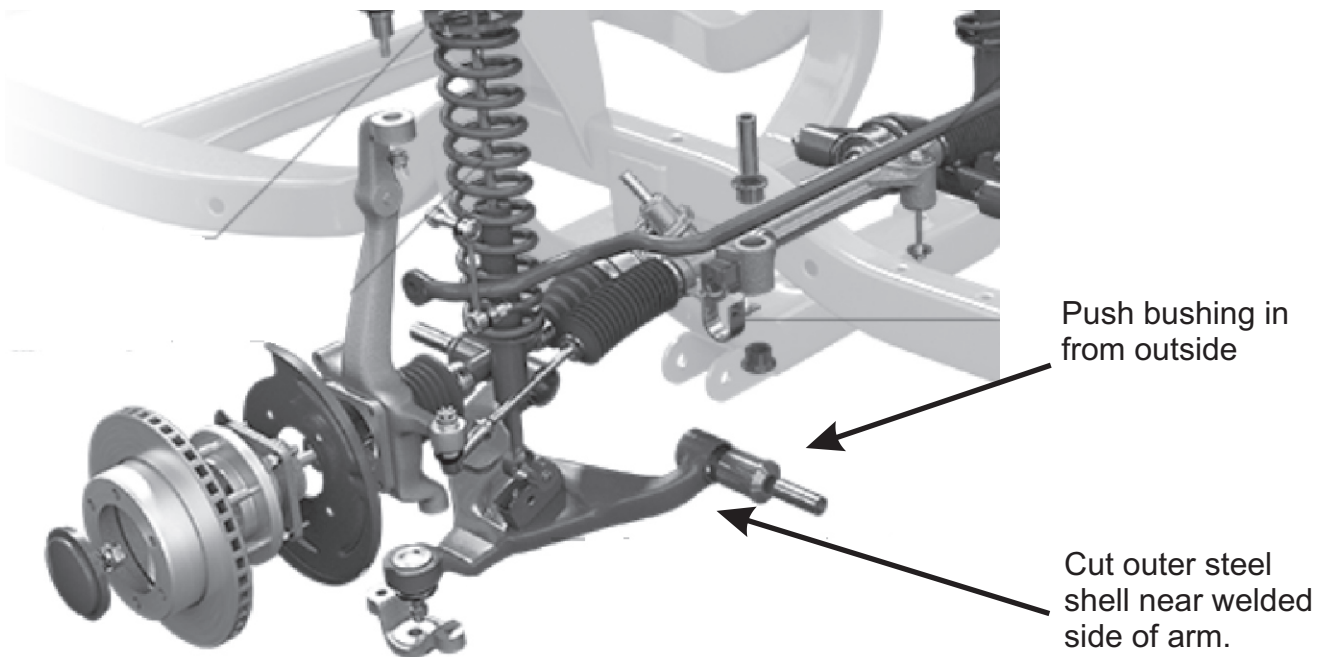

**N.B:** It is recommended that a licenced workshop or tradesperson carry out the above procedure and that workshop manual and relevant safety procedures are followed in addition to the above.