

FITTING INSTRUCTIONS

Steering Coupling

WARNING: If vehicle is fitted with aftermarket extractors we do not recommend using urethane steering couplings unless a heat shield is fabricated to protect from excessive direct heat. If used without heat shield damage may be caused to the coupling resulting in steering failure.

N.B: These instructions should be used in conjunction with workshop manual.

1. Remove the original steering coupling and column from the vehicle as recommended in the workshop manual.
2. Grind or drill the heads from the rivets and punch remainder from assembly to allow disassembly of steering coupling, take particular note of safety brackets and reinstall it their original position on reassembly of coupling.
3. Clean any rubber deposits from the assembly.
4. Inspect all of the steering components for damaged, bent, or worn components and replace as necessary.
5. Install new replacement coupling (ensure that the below sequence is carried out for correct installation).
6. When assembling the coupling the bolts supplied are longer than necessary. The over length threaded sections will act as the safety drive pegs. Take particular care to have the bolts facing in the correct direction, these bolts replace the riveted pegs discarded from the original unit.

N.B: In all applications the bolt heads and lock nuts must seat on the original metal flange or the washer supplied, at no time must a bolt head or nut seat directly against the coupling

7. Re-assemble the steering coupling and column as recommended in workshop manual
Tighten all components to manufactures recommended torque settings.

CORRECT ASSEMBLY SEQUENCE

CRUSH TUBE & BOLT ASSEMBLY

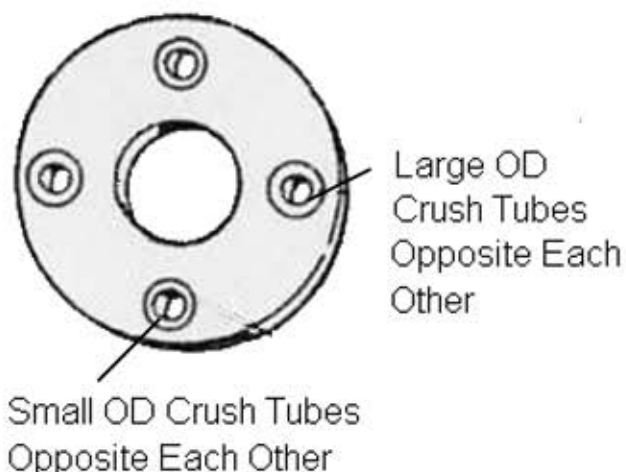
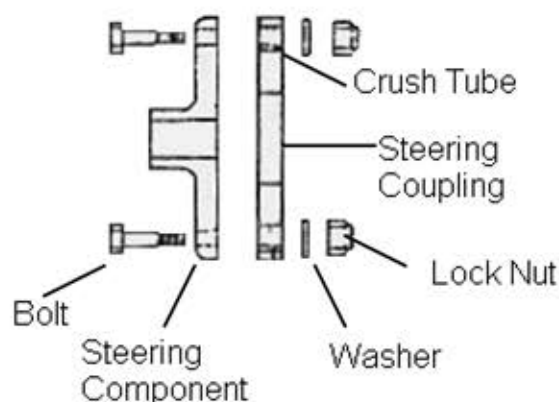

N.B: It is recommended that a licenced workshop or trades person carry out the above procedure and that workshop manual and relevant safety procedures are followed in addition to the above.