



# TOWBAR INSTALLATION INSTRUCTIONS

PART NUMBER 03343RW

KIA CARNIVAL YP MY19 CL4



## PRODUCT DETAILS:

Part Number:	03343RW	Maximum Towing Braked:	2000	kg
ECU Number:	04826	Maximum Towing Unbraked:	750	kg
Tail Harness Length Required:	1200 mm	Maximum Static Ball Load:	200	kg
TBM/Lug Part Number:	21148			
Wiring Part Number:	102334-WL			

## FITTING DETAILS:

Towbar Installation Time:	60 Mins.	Vehicle Coding Required:	NO
Wiring Installation Time:	45 Mins.	RPA Disable/Other:	YES
Total Installation Time:	105 Mins.	Note:	
Bumper Cut Required:	Yes		<ul style="list-style-type: none"><li>Electric brake blue wire location next to grommet</li></ul>



# TOWBAR INSTALLATION INSTRUCTIONS

PART NUMBER 03343RW

KIA CARNIVAL YP MY19 CL4

**ENSURE THAT INSTRUCTIONS ARE UNDERSTOOD PRIOR TO FITMENT.**

## **i** BEFORE YOU START:

Hayman Reese recommends that instructions are read completely prior to fitment. Check all hardware items have been included refer to assembly diagram. Please ensure this towbar is only fitted to vehicle models as per Hayman Reese application guide ([www.haymanreese.com.au](http://www.haymanreese.com.au)).

### **Bumper Cuts**



Vehicle and bumper variations can and do occur during vehicle manufacture after initial towbar design. Fitment of towbar to vehicle and accuracy of bumper cut must be assessed prior to any bumper modifications made. Incorrect bumper cuts are not covered under Hayman Reese warranty.

**NOTE: Bumper cuts need to be approached with care, refer to notes below.**

- Bumper centreline – where the centreline of the bumper needs to be determined, the installer must assess centre point by measurement of bumper width or determining two symmetrical reference points to give centreline.
- Bumper edge – To assist with accurate bumper cut measurement, reference to the start of the bumper edge is now being commonly used.
  - Measure from bottom edge along bumper and around corner to the 70 mm point (Figure 1).
  - Do not measure from visible bumper front of corner, upwards (Figure 2).

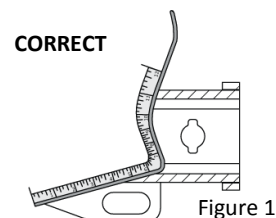

Figure 1

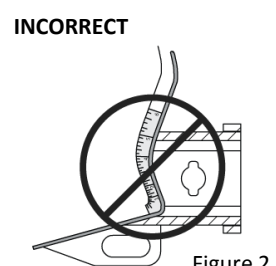

Figure 2

### **Drilling**

- For any required drilling during installation, ensure that the area is clear of fuel, electrical & other components that may be damaged.
- All holes drilled into the body panels shall have all burrs & swarf removed then coated with a suitable rust preventative paint.

### **Bolts/Fasteners**

- Ensure that all hardware is fastened to correct torque as specified in this fitting instruction.
- All fasteners supplied with this product are used to achieve a specified clamp loading. If replacement is required ensure that fasteners of the same grade and class are used.



**NOTE: Achieving correct torque is critical to proper installation and responsibility of the installer. Towbar failures attributed to tension issues from over tightening or under tightening are not covered by Hayman Reese warranty.**

### **Product Labels**

- a. Towbar load rating sticker provided with this product shall be conspicuously located on inside rear end of the driver's door.
- b. Powertrain Control Module (PCM)/Body Control Module (BCM) upgrade warning label will be provided in towbar kit for vehicles as required. Affix warning label in door and owner's handbook.

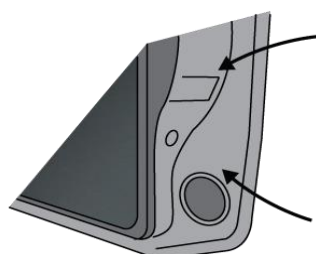

Place **Load Rating sticker** inside driver's door here

Place **Vehicle PCM/ BCM upgrade warning label** in door AND on front cover of owner's service handbook

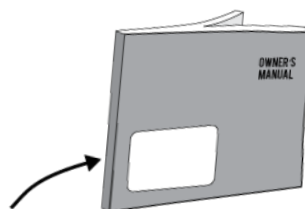

## **WARNING:**

**Do not, drill, cut, weld or otherwise modify the towbar.**

**FOR TOWING PURPOSES ONLY - This towbar is designed and tested by Hayman Reese to adhere to ADR 62/02 which provides only for the expected load demands of towing.**



# TOWBAR INSTALLATION INSTRUCTIONS

PART NUMBER 03343RW

KIA CARNIVAL YP MY19 CL4

## **i** TOWBAR ASSEMBLY DIAGRAM

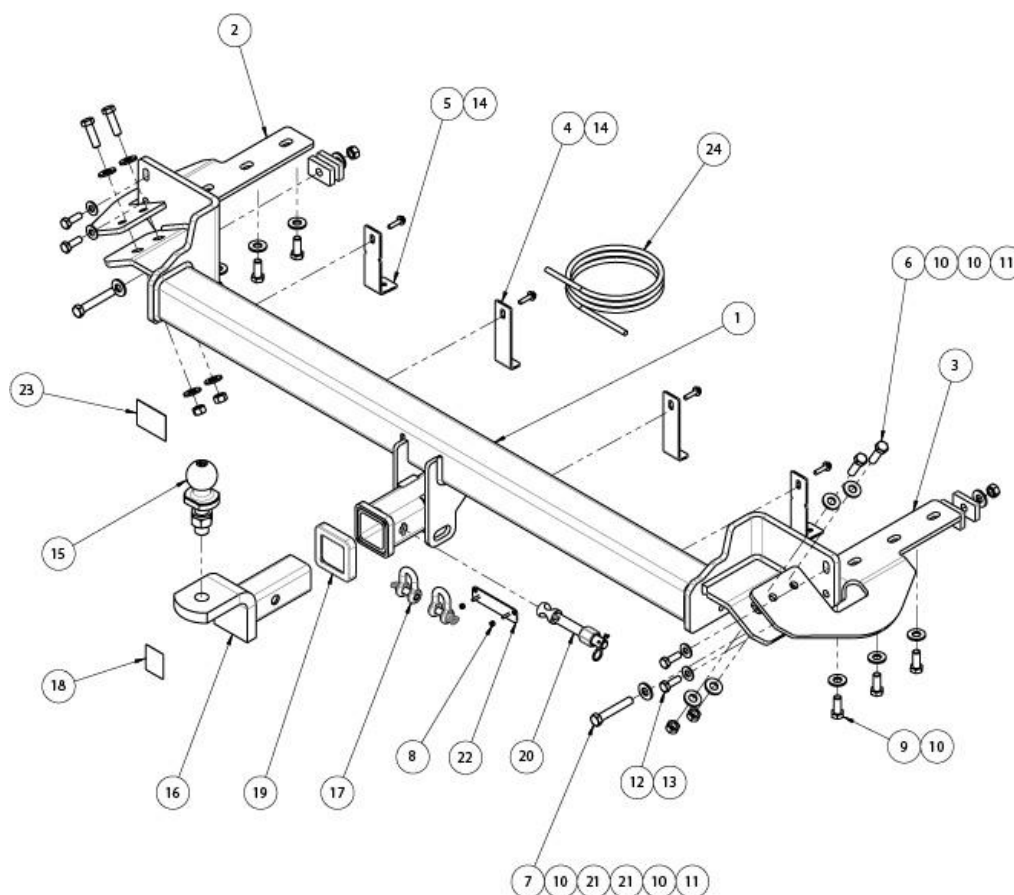

ITEM	DESCRIPTION	QTY
1	KIA CARNIVAL YP CL4	1
2	SIDE ARM – LHS	1
3	SIDE ARM – RHS	1
4	INNER BUMPER TAB	2
5	OUTER BUMPER TAB	2
6	BOLT HEX HD M12x40x1.25P	4
7	BOLT HEX HD M12x75x1.25P	2
8	NUT NYLON LOCK HEX M4x0.7P	2
9	SET SCREW HEX HD M12x30x1.25P	6
10	WASHER FLAT M12	18
11	NUT HEX M12x1.25P	6
12	SET SCREW HEX M10x30x1.25P	4

ITEM	DESCRIPTION	QTY
13	WASHER PLAIN M10x23x2	4
14	TEK SCREW 14-20 HEX HD 22mm	4
15	TOWBALL 50mm	1
16	TRAILER BALL MOUNT	1
17	"D" SHACKLE 10mm	2
18	HAYMAN REESE LOGO STICKER	1
19	HITCH BOX COLLAR COVER	1
20	SMART PIN	1
21	LOOSE PLATE 50x32x10	4
22	PLUG BRACKET	1
23	ACRYLIC COMPLIANCE LABEL	1
24	WIRING LOOM	1



# TOWBAR INSTALLATION INSTRUCTIONS

PART NUMBER 03343RW

KIA CARNIVAL YP MY19 CL4

1. Carefully remove cover surrounding tail light.

Repeat for opposite side of vehicle.

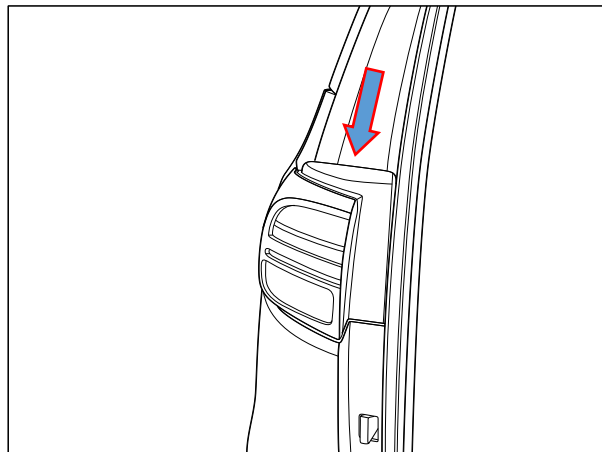

2. Remove 2 x screws that were concealed under tail-light covers.

Repeat for opposite side of vehicle.

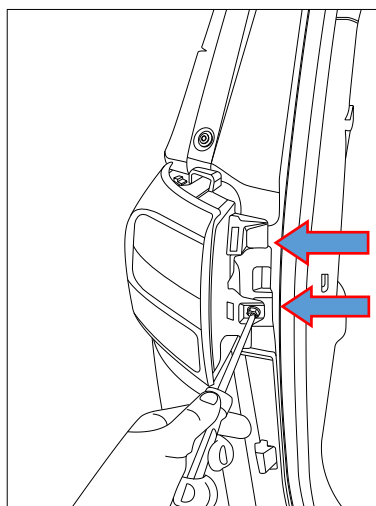

3. Carefully remove and disconnect tail light from vehicle.

Repeat for opposite side of vehicle.

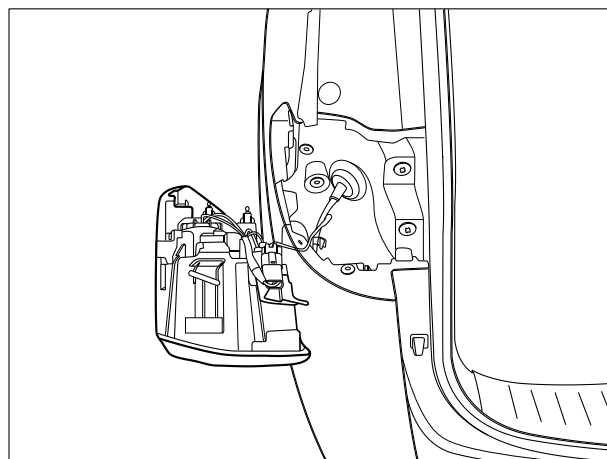



# TOWBAR INSTALLATION INSTRUCTIONS

PART NUMBER 03343RW  
KIA CARNIVAL YP MY19 CL4

4. Remove 1 x scrivet from top of the bumper in light cavity.

Repeat for opposite side of vehicle.

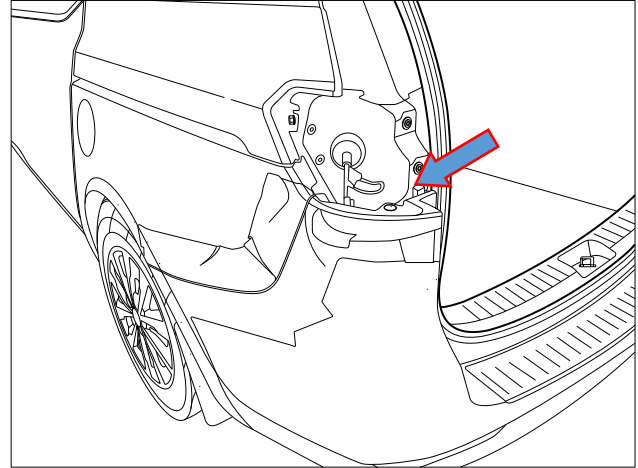

5. Remove 3 x screws from around wheel arch and 1 x scrivets from underneath mud flap. Remove mud flap.

Repeat for opposite side of vehicle.

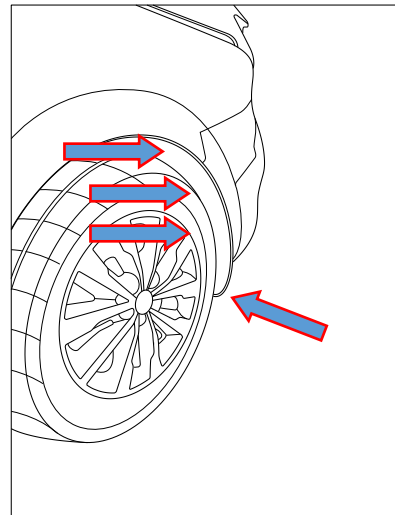

6. Remove 1 x screw at the top of the wheel arch.

Repeat for opposite side of vehicle.

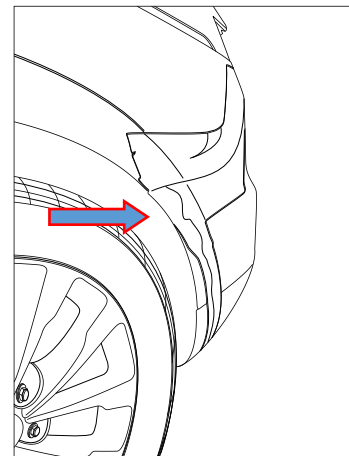

7. Remove 9 x scrivenets located on the underside of the bumper.

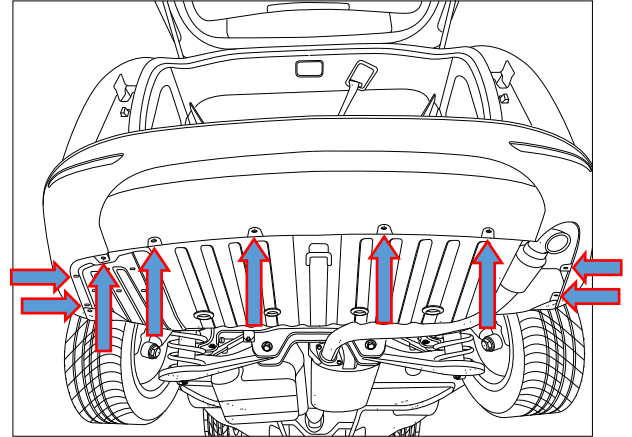

8. Carefully unclip and remove rear bumper, peeling bumper from edge of wheel.

Disconnect parking sensor loom where applicable.

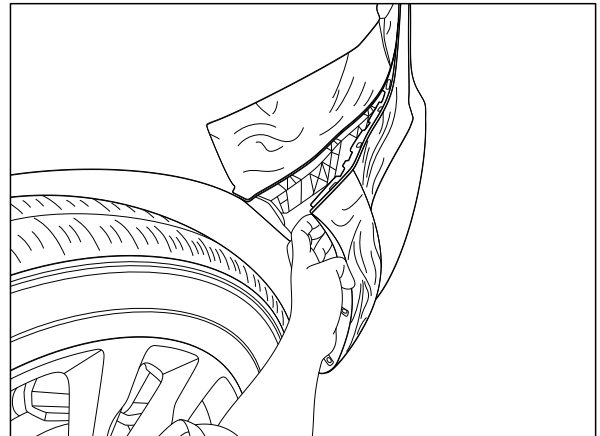

9. Remove 6 x hex head bolts (3 per side) securing the rear impact beam to the rear panel of the vehicle; carefully remove and discard rear impact beam and bolts.

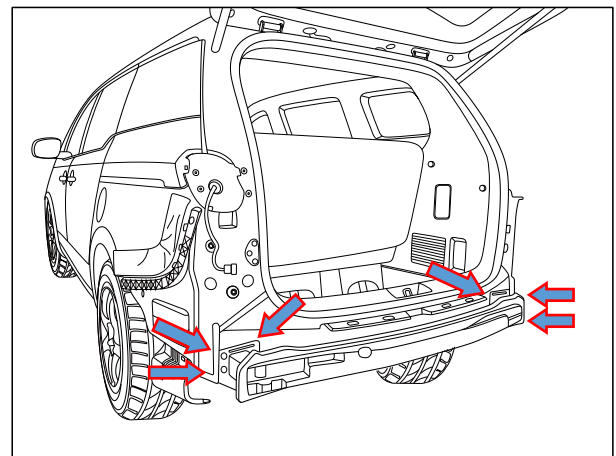



# TOWBAR INSTALLATION INSTRUCTIONS

PART NUMBER 03343RW

KIA CARNIVAL YP MY19 CL4

10. Remove guard on side of vehicle by unscrewing 2 x M10 screws.

Repeat for opposite side of vehicle.

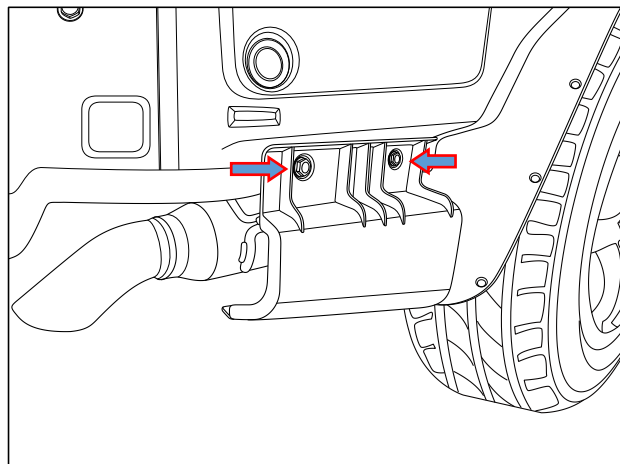

11. Supporting the rear end of exhaust, disconnect exhaust mount bracket from rubber exhaust hanger to allow access to the chassis rail.

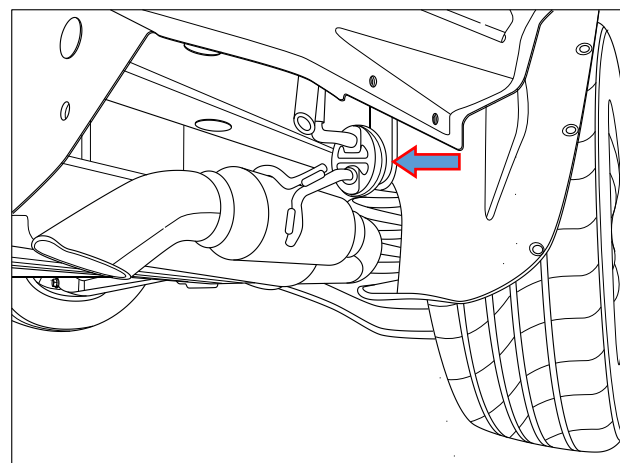

12. Remove cover from forward hole in chassis rail under vehicle and discard.

Repeat for opposite side of vehicle.

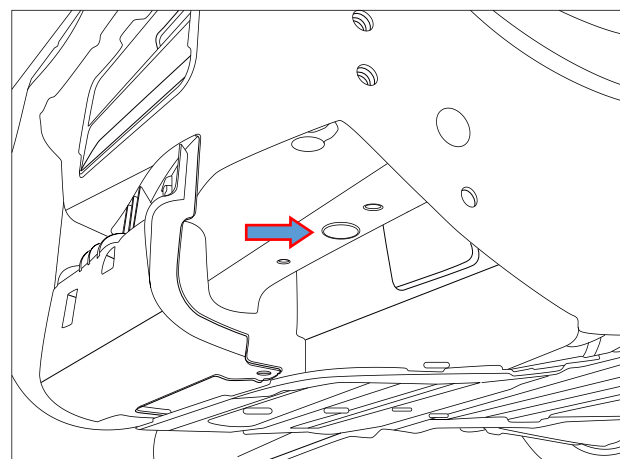



# TOWBAR INSTALLATION INSTRUCTIONS

PART NUMBER 03343RW

KIA CARNIVAL YP MY19 CL4

13. Loosely secure one side arm of towbar to the underside of the chassis rail using 3 x M12 x 30 bolts complete with 1 x M12 flat washer per bolt.

Repeat for opposite side of vehicle.

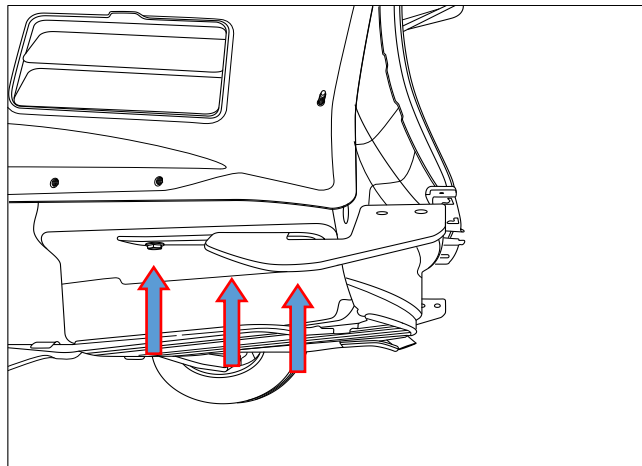

14. Loosely secure bumper tabs onto towbar welded assembly using 4 x tek screws provided.

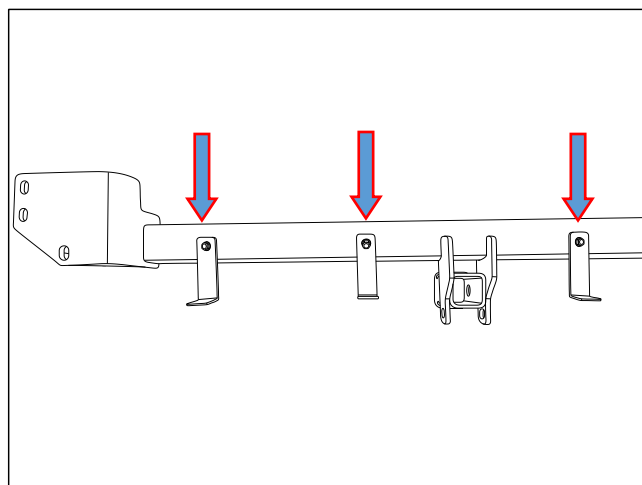

15. Loosely secure welded towbar assembly to rear panel of vehicle using 4 x M10 x 30 hex head bolts (2 per side) complete with 1 x M10 flat washer per bolt.

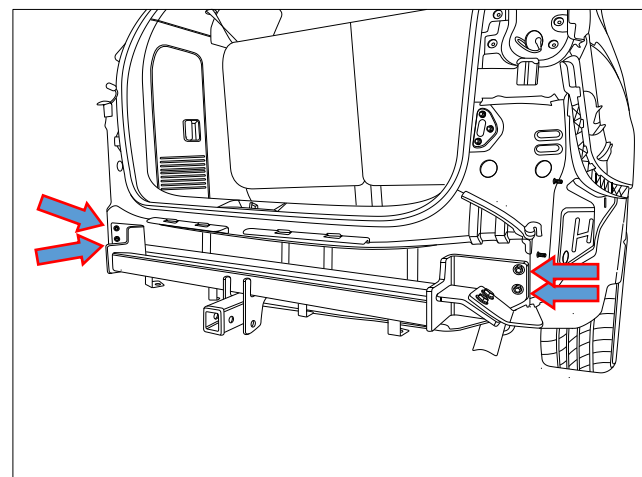



# TOWBAR INSTALLATION INSTRUCTIONS

PART NUMBER 03343RW

KIA CARNIVAL YP MY19 CL4

16. Loosely secure both side arms to towbar welded assembly using 4 x M12 x 40 bolts (2 per side arm), complete with 2 x M12 flat washers and 1 x M12 nut per bolt.

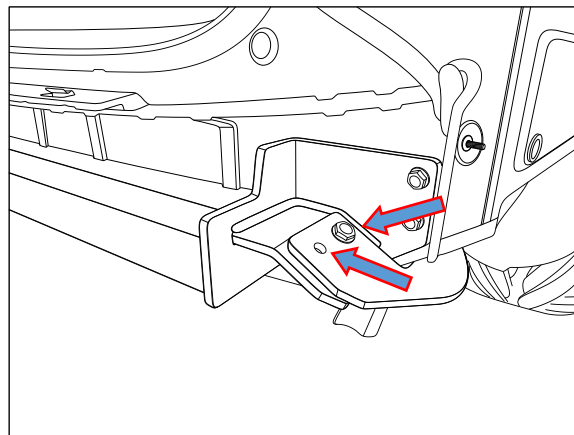

17. Loosely secure towbar welded assembly to side arm through rear panel of vehicle with 2 x M12 x 75 bolts (1 per side), complete with 2 x M12 flat washer, 1 x M12 nut and 2 x 10mm spacer plates (placed between rear panel of vehicle and side arm) per bolt.

Tighten all fasteners to the torques listed below:

**M12- 89Nm**

**M10- 48Nm**

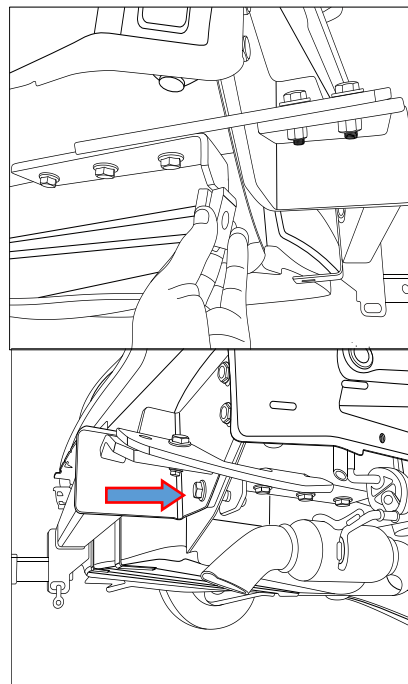

18. Identify the centre of the bumper and cut out a 200mm tall x 85mm wide rectangle, starting from the bottom edge of the bumper, as measured following the outer edge of the bumper.

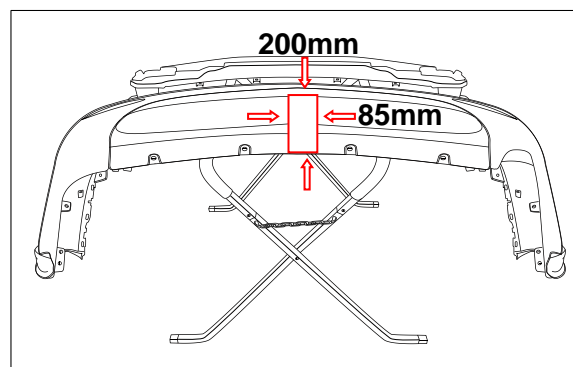



# TOWBAR INSTALLATION INSTRUCTIONS

PART NUMBER 03343RW

KIA CARNIVAL YP MY19 CL4

19. Mark out and drill 2 x Ø5mm holes 69mm apart on bumper skin to support plug bracket. Feed bracket through drilled holes prior to reinstalling bumper.

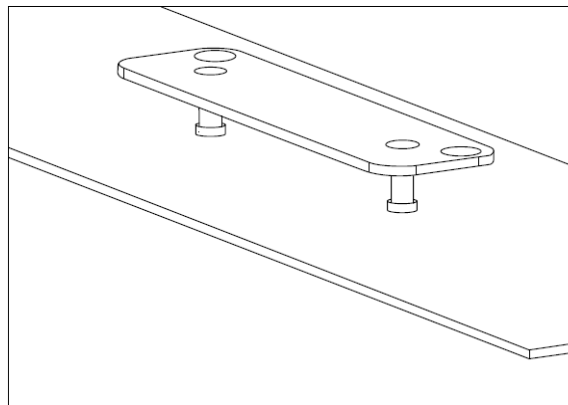

## IMPORTANT

Due to possible vehicle variations, always confirm any noted vehicle colour wires with a multi-meter to ensure the correct function is identified before soldering or scotch locking. For vehicle wires denoted with two colours (example; RED/GREEN) the first colour will always be the main wire colour while the second colour is the thinner trace colour on the wire.

20. Inside the luggage compartment, remove the floor carpet (1) and then remove the rear trim (2) by removing two fasteners (3) (one fastener shown).

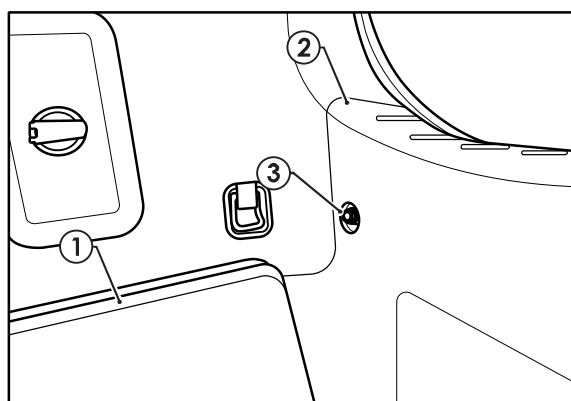

21. Remove the LHS upper 'D' pillar trim bolt (1) and then dislodge the trim (2).  
**Repeat for the RHS.**

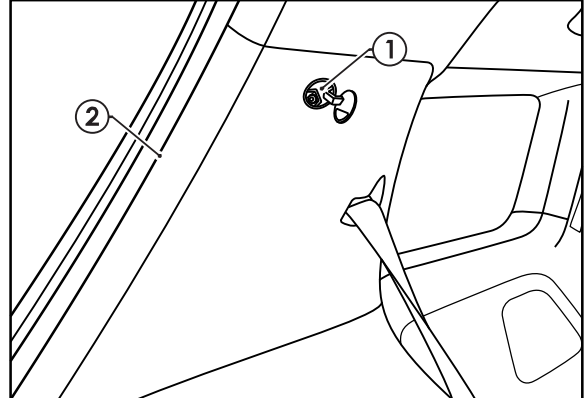

22. Underneath the 'D' pillar trim area, remove the exposed fastener (1) from the RHS luggage compartment trim (2) and then dislodge enough of the trim to gain access to the vehicle wiring.  
**Repeat for the LHS.**

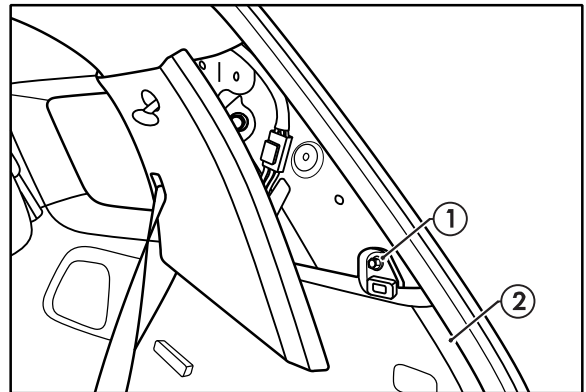

23. At the exterior RHS rear quarter of the vehicle, remove the vehicle grommet (1) and confirm grommet hole diameter is  $\varnothing 30\text{mm}$ . If not, drill out grommet hole to  $\varnothing 30\text{mm}$ .  
**Ensure the interior area behind the drilling location is clear of any obstructions before drilling.**

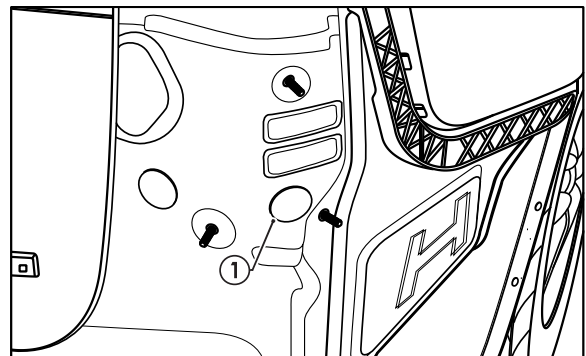



# TOWBAR INSTALLATION INSTRUCTIONS

PART NUMBER 03343RW

KIA CARNIVAL YP MY19 CL4

24. From the inside of the vehicle, feed the Blue connector, the power connector and the tail light patch through the previously removed 30mm grommet blank (1) to the outside of the vehicle.
25. Seat the grommet on the trailer patch harness (102334-WL) in the 30mm hole.
26. Route the tail light patch connectors (2) up to the RHS tail light connector and patch in between the vehicle wiring (3) and tail lamp connector.

**Note: Ensure grommet is seated correctly and makes a good seal.**

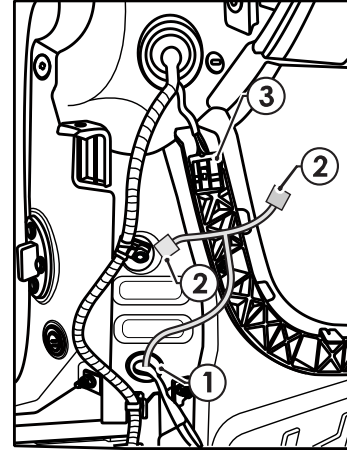

27. In the RHS interior rear quarter, locate an area on the vehicle sheet metal suitable to mount the ECU (1) (P/No: 04826). Using an alcohol wipe (not supplied), clean the sheet metal area where the ECU will be mounted (2).
28. Connect the trailer patch ECU connector (3) to the ECU (1).
29. Adhere the supplied double sided tape to the ECU (1) and mount to the cleaned area on the vehicle sheet metal.

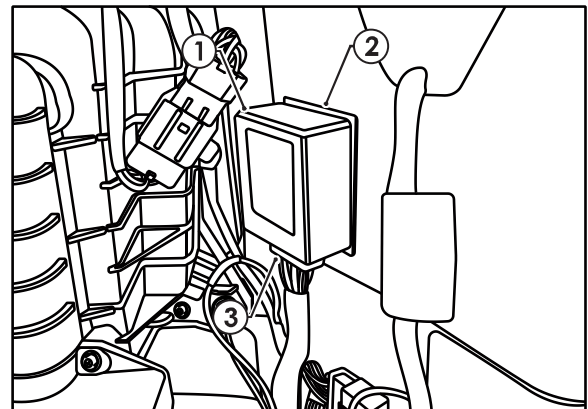

30. Route the trailer patch harness (1) across to the LHS tail light area.

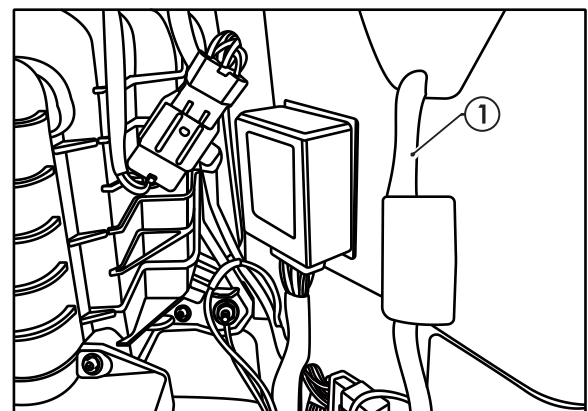



# TOWBAR INSTALLATION INSTRUCTIONS

PART NUMBER 03343RW  
KIA CARNIVAL YP MY19 CL4

31. At the LHS exterior, locate the tail light harness GREY wire. Trace this wire back to the interior LHS luggage compartment area.

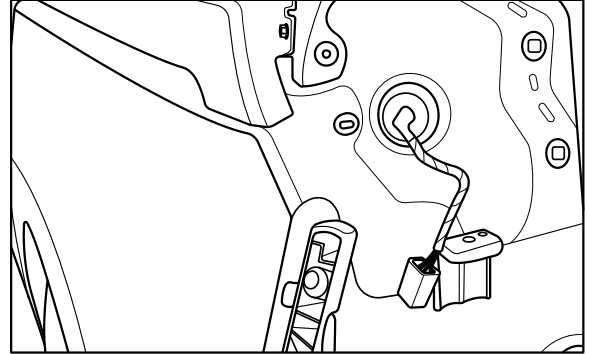

32. Secure the supplied Ezy-Tap (1) onto the vehicle harness GREY L.IND wire (2) and connect the trailer patch YELLOW/BLACK wire terminal (3) to the scotch lock (1).

Vehicle Wire	Trailer Patch	Function
GREY	YELLOW / BLACK	L. IND

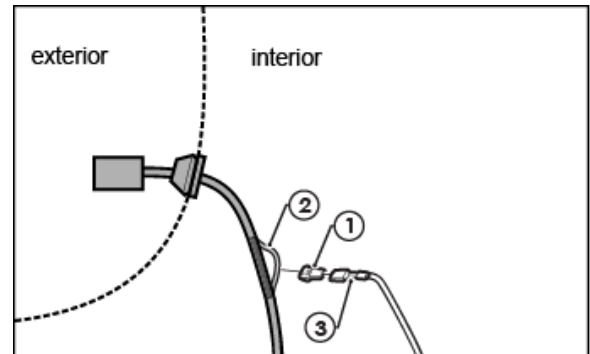

33. At the rear exterior of the vehicle, mount the tail harness socket (1) to the towbar mounting bracket using M4 fasteners (not supplied).
34. Route the tail harness (tail length: 1200mm) (2) across the RHS towards the blue connector.

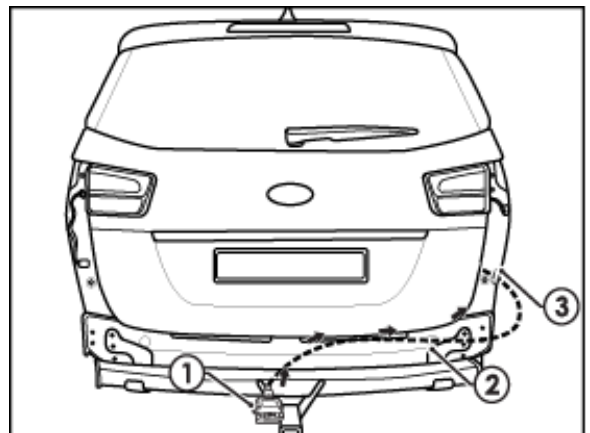

35. Connect the tail harness 8-way connector (1) to the trailer patch 8-way mating connector (2).  
Using electrical greaser water proof the connector.

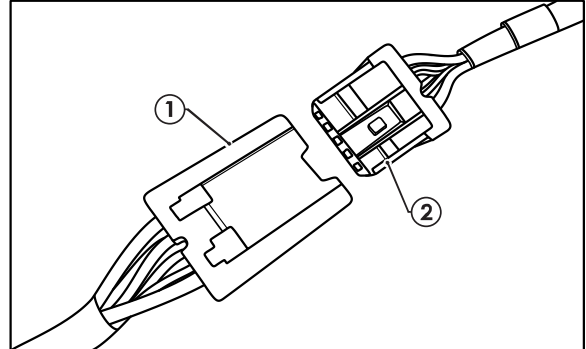

36. Connect the trailer patch ORANGE wire 1-way connector (1) to the power harness (P/No: 04825) 1-way connector.

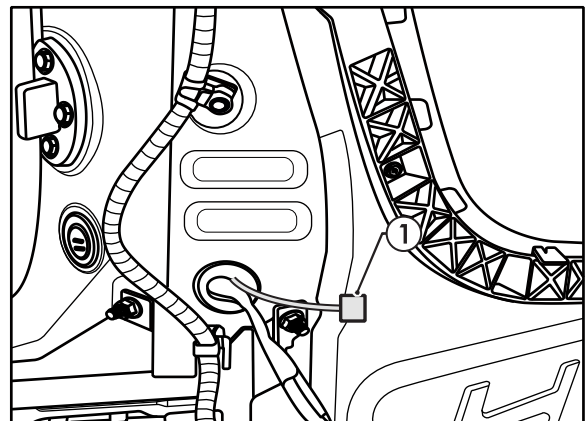

37. Route the power harness (1) underneath the RHS of the vehicle following the chassis rail all the way to the engine bay battery. Secure the harness to the vehicle using cable ties (not supplied) at 200mm intervals. Ensure to keep harness clear of any areas of extreme heat, moving parts or sharp surfaces.

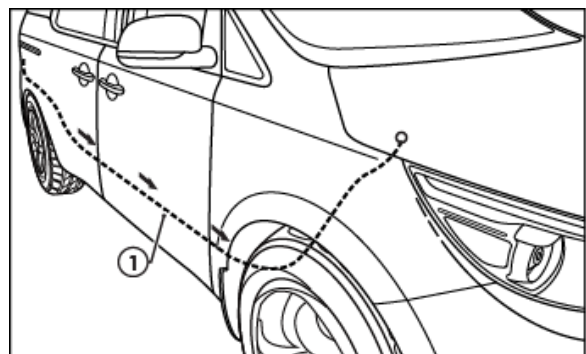



# TOWBAR INSTALLATION INSTRUCTIONS

PART NUMBER 03343RW

KIA CARNIVAL YP MY19 CL4

- 
38. In the engine bay, secure the power harness ring terminal (1) to the battery positive terminal mounting point (2).

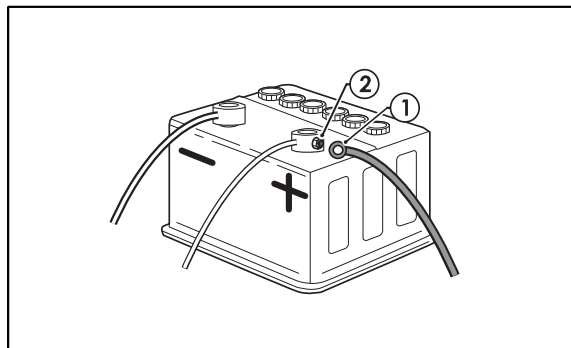

- 
39. Reconnect the battery negative terminal.  
40. Reconnect the rear tail lights.  
41. Test the trailer harness functions using a light board or multi-meter.  
42. Secure all harnesses using cable ties (not supplied).  
43. Re-fit removed parts and secure all fasteners, ensuring there are no squeaks or rattles.  
44. Place the instructions in the glove box after fitment.

- 
45. Reinstall exhaust mount, bumper, mud flap and fasteners following steps 1 to 11 in reverse.  
46. Align holes below bumper with bumper tabs on towbar. Once aligned tighten tek screws and replace scrivets
-



# CUSTOMER INFORMATION

PLACE THESE INSTRUCTIONS IN THE  
VEHICLE'S GLOVEBOX AFTER INSTALLATION

**THANK YOU FOR PURCHASING HAYMAN REESE.  
WITH CORRECT MAINTENANCE AND CARE THIS PRODUCT WILL PROVIDE A  
LIFETIME OF TROUBLE-FREE OPERATION.**

## **i** TOWBAR MAINTENANCE AND CARE:

1. Hayman Reese recommend that the towbar LUG or TBM (tow ball Mount) Pull Pin and R-clip are removed and stored when not in use. Removal of LUG or TBM (tow ball mount) is advisable when not in use to assist with any of the following.
  - Ensure rear number plate is not obscured.
  - Allow maximum available departure angle and prevent any potential interference.
  - Prevent possible interference with vehicles reverse sensors or camera detecting a tow ball mount as an obstruction during reversing.
  - Removes towball mount as an obstruction for when moving around the rear of the vehicle.
2. Hayman Reese recommends routine inspection of your towbar to ensure trouble free towing.
  - Bolt security and tension should be regularly inspected and checked for correct tension. Replace any worn or defective parts with suitable grade & class fasteners. Inspection should be requested to coincide with vehicle major services.
3. It is the owner's responsibility to ensure towing and down ball weight capacities of the towing vehicle are not exceeded.
  - Towing and down ball weights allowable may differ according to model variations. Please refer to owner's manual or vehicle dealer to confirm exact rating for your vehicle model variant.
  - It is not uncommon for the vehicle tow rating to differ from the towbar rating. When this occurs, the lesser rating must be adhered to.
  - For vehicles fitted with enhanced vehicle functions that may be altered/changed when towing i.e Trailer sway mitigation, blind spot detection, adaptive cruise control etc. Please consult owner's manual to understand changes enabled when towing and after towing.

## **i** WARRANTY INFORMATION:

Hayman Reese Towbars are covered by a Lifetime Warranty.

Our goods come with guarantees that cannot be excluded under the Australian Consumer Law. You are entitled to a replacement or refund for a major failure and for compensation for any other reasonably foreseeable loss or damage. You are also entitled to have the goods repaired or replaced if the goods fail to be of acceptable quality and the failure does not amount to a major failure.

For further details please visit [www.haymanreese.com.au/warranty](http://www.haymanreese.com.au/warranty) or contact customer service on 1800 812 017 or [info@haymanreese.com.au](mailto:info@haymanreese.com.au).



# CUSTOMER INFORMATION

PLACE THESE INSTRUCTIONS IN THE VEHICLE'S GLOVEBOX AFTER INSTALLATION

## HAYMAN REESE SMART PIN

Your Hayman Reese towbar is equipped with Smart Pin technology to help reduce towbar tongue rattle in most driving conditions. Please ensure below instructions are understood and routine maintenance is carried out to ensure best towing experience.

**i** Regularly inspect for wear and check the tightness of the Smart Pin Nut. Follow instructions below to re-tighten the nut as necessary when movement and noise in the tow ball mount is noted.

- Before towing, ensure R-Clip is properly installed and Smart pin nut is installed and tensioned. Replacement parts are available from your Hayman Reese Distributor.

## TOWBALL MOUNT REMOVAL/INSTALLATION

### STEP 1

Insert Trailer Ball Mount (TBM) (a) into towbar hitchbox (b), aligning hole in TBM shank (c) with hole in hitchbox (d) (Fig. 1)

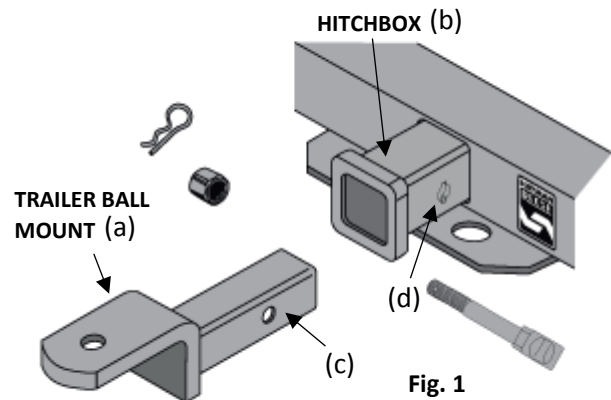

### STEP 2

Insert Smart Pin (e) through hole in hitchbox and hole in TBM shank (g); ensure the locators are inserted into the notches in the hitchbox (Fig. 2)

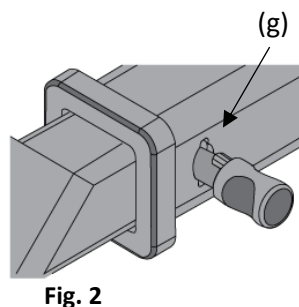

### STEP 3

Screw Smart Pin Nut (f) onto Smart Pin (g); tighten Smart Pin Nut until finger tight, ensuring TBM is restrained from up and down movement.

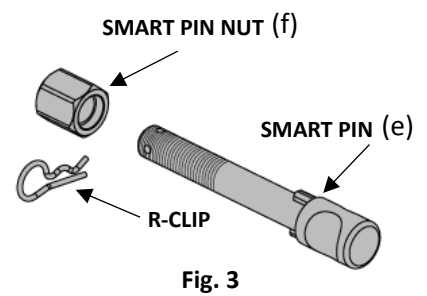

### STEP 4

Tighten Smart Pin Nut by turning nut a further 1/8th of a turn in the clockwise direction using a 24mm spanner (Fig. 4).

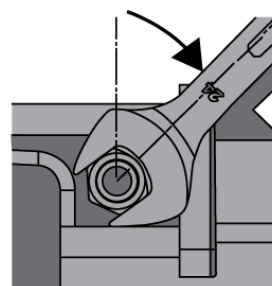

### STEP 5

Install Smart Pin R-Clip through the hole that provides best clearance or easiest access. (Fig. 5)

