

Install Guide

Rear Toe Control Arm Bushing

Nissan Patrol Y62 2010+

Nolathane[®]

Note: These components must be fitted by a qualified person only, as per the manufacturers' service manual. Also, all relevant safety procedures are followed in addition to the following. Photos are an indication and may vary slightly in appearance from the actual product.

Kit Contents:

Standard Alignment (46490):

- 2 x SPF4130 Bush
- 2 x Tube 28.57x14.3x55

Toe Correction (46491):

- 2 x SPF4131 Bush
- 2 x Tube 28.57x14.3x55

NOTE: Polyurethane bushings must be fitted to both sides of the vehicle.

1. Wheel align vehicle before commencement of work and note settings.
2. With vehicle on hoist or jack stands, remove the rear toe control arms.
3. Remove the original bushes including the steel shell.
4. Apply the grease supplied to the toe arm housing and the outside surface of the bush.
5. Using the appropriate pressing tools, support the toe control arm and press the new '4130' or '4131' bushes in the arm housing. Note the shell side of the bush is the last part to be pressed in the control arm housing, Figure 1. If you have purchased the SPF4131K, adjust the bushes before pressing the shell part in the housing, Figure 2.

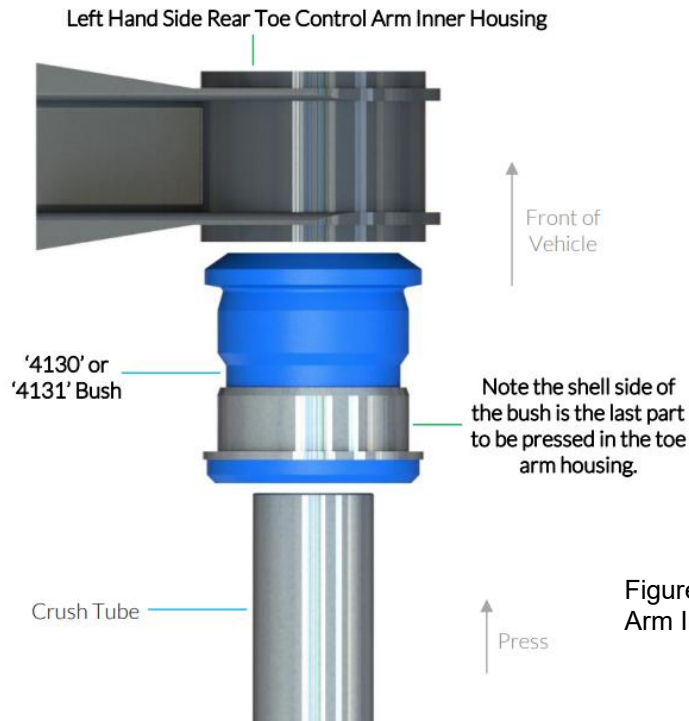

Note: use a flat plate to cover all the surface of the end of the bush to press the shell in the housing.

Figure 1: LHS Rear Toe Control Arm Inner Bushing (Top View)

6. Apply the grease supplied to the bore of the bush and the outside surface of the steel crush tubes, then push the crush tubes in the bush
7. Refit the control arms to the vehicle and tighten the bolts to manufacture's torque settings
8. Reassemble the rest of the vehicle and carry out wheel alignment.

Install Guide

Rear Toe Control Arm Bushing

Nissan Patrol Y62 2010+

Nolathane[®]

View from the Front of Vehicle

46490 – Standard Replacement

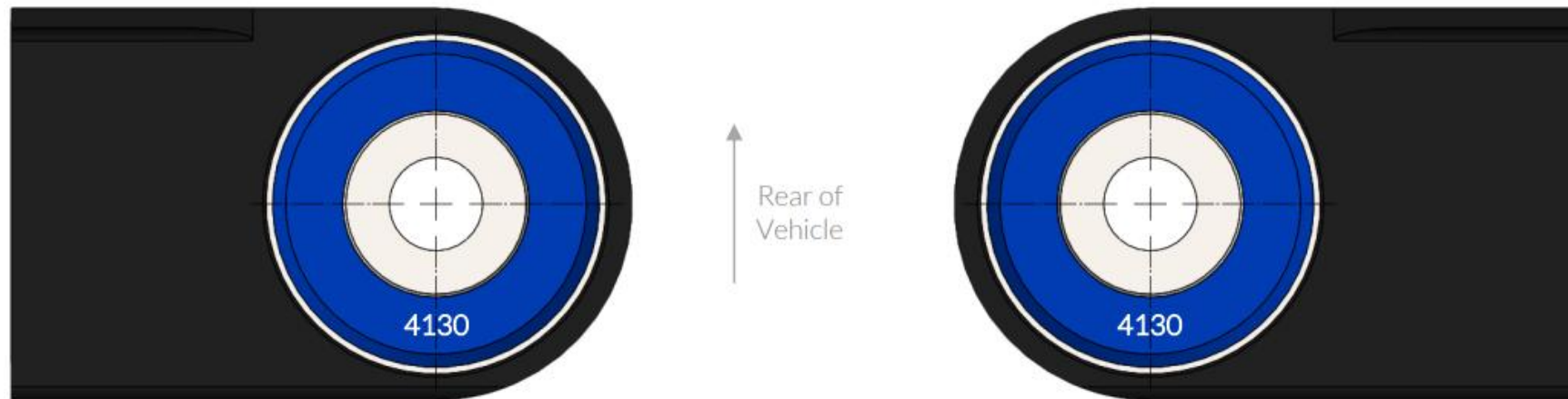

46491 – Toe Correction

This kit adds at least 5mm to the current toe measurement



Figure 2: Toe Control Arms Inner Bushing (Front View)