

Install Guide

Front Upper Control Arms

- Live Adjustable Camber and Caster

Nolathane®

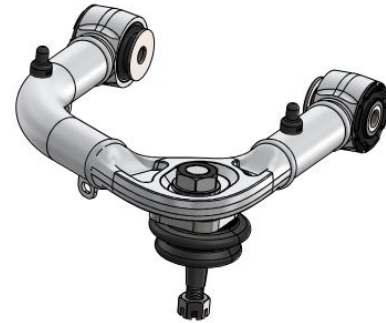

Application - Ford Ranger PX PX2 PX3 2011-2021
- Mazda BT-50 UP UR 2011-2021

(Always refer to current catalogue listing)

- Contents** - 2x adjustable, forged, tubular arms
- complete with H/D ball joints
 - and bushings.
 - 4x washers
 - Grease

Nolathane recommends checking current tyre wear patterns in addition to noting current wheel alignment settings prior to dismantling.

- Raise vehicle evenly and safely support.

Never rely on a Jack only

- Proceed to remove front wheels.
- Pop off ABS wires from under the control arm.

Refer RH image.

- Remove R clip from ball joint.
- Loosen nut slightly and strike hub to break ball joint taper.

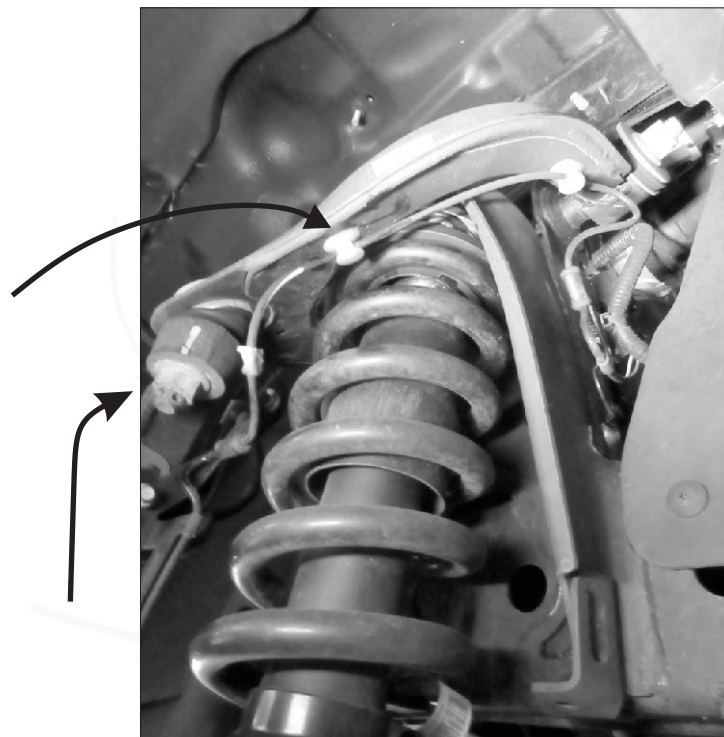

Refer Page 2

It is recommended that a licenced workshop or tradesperson carry out the above procedure and that workshop manual and relevant safety procedures are followed in addition to the above.

Install Guide

Front Upper Control Arms

- Live Adjustable Camber and Caster

Large inner nut

Continued - page 2:

- Next, remove the inner bushing bolts.
- Start by loosening the large front nut.
- Now pull out the long bolt from the rear.

Refer RH image.



- Grease new bushing sides faces with the supplied grease.
- Bolt up the arms to vehicle using the original bolts.

IMPORTANT - place supplied flat washers on inside of bushing.

- Bolt new ball joint spindle to the vehicles hub/up-right. Tighten using the new castle nut. Tighten to 110Nm.

Note - the ball joint has been pre-set to suit vehicles with a 40-50mm lift.

Refer page 3

Supplied Flat Washer

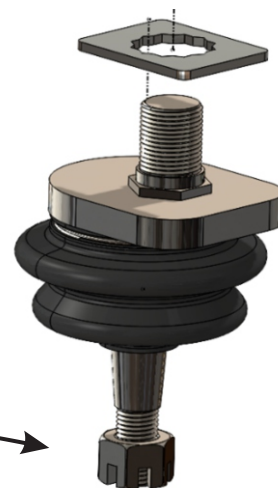

Castle nut
Tighten to 110Nm

It is recommended that a licenced workshop or tradesperson carry out the above procedure and that workshop manual and relevant safety procedures are followed in addition to the above.

Install Guide

Front Upper Control Arms

- Live Adjustable Camber and Caster

Tip - the bushing supplied being free spinning offer the ability to tighten the bushing bolts while the wheels are hanging.

- Please refer to below and next page for further adjustments.
- A general rule of thumb for the Ranger/BT, is that 8mm of ball joint movement equals approx. 1 degree of camber and caster change.
- The ball joint can be rotated through 12 fixed positions by re-positioning the hex on the ball joint into the double hex washer. Refer RH pic.

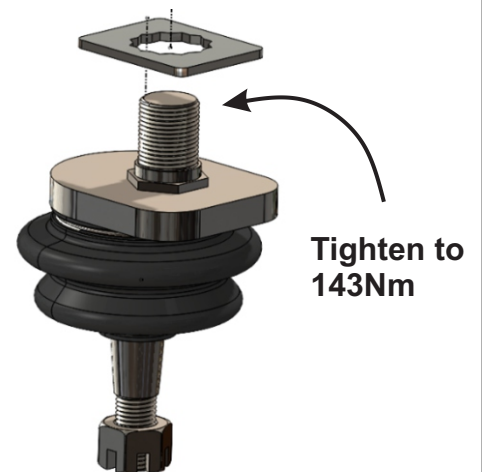

Using the previously mentioned rule of thumb, the below ball joint positions will roughly result in the following changes to the alignment relative to the centre:

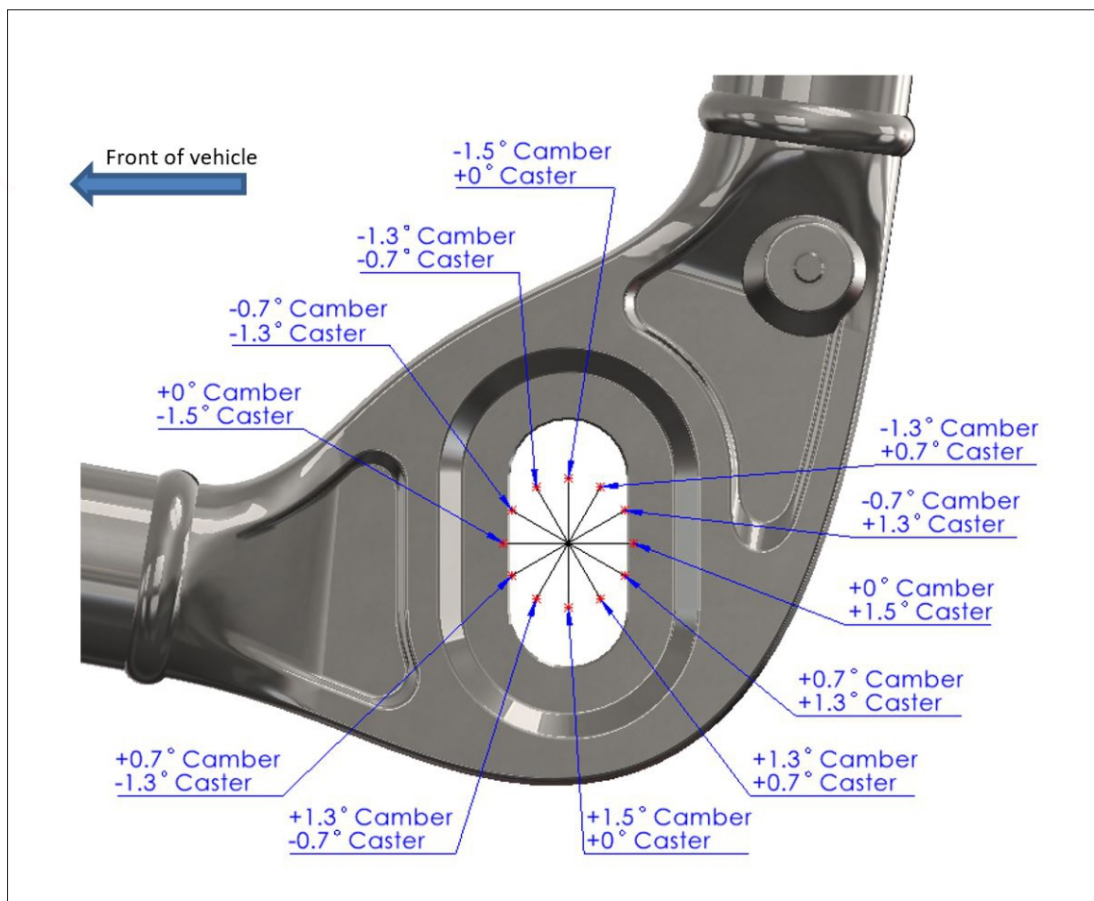

It is recommended that a licenced workshop or tradesperson carry out the above procedure and that workshop manual and relevant safety procedures are followed in addition to the above.

Install Guide

Front Upper Control Arms

- Live Adjustable Camber and Caster

- In conjunction with rotating the ball joint, the ball joint can slide in and out on the slot which will allow an approx +/- 1.0 degree of addition camber.

IMPORTANT - the large upper nut must be tensioned to 143Nm.

- Road test vehicle after the wheel alignment.
- Re-check all bolts after 500kms

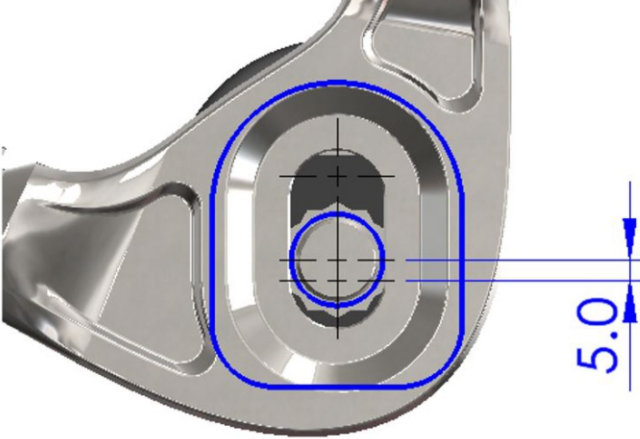
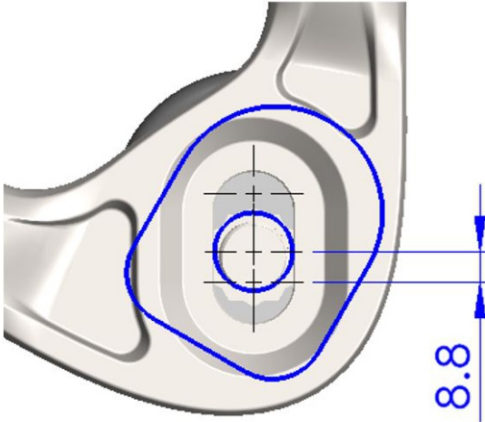
Recommended settings for 50mm lift (2")	Recommended settings for 75mm lift (3")
	
<p>Position the ball joint pointing straight inwards and slide the ball joint 5mm from the outside.</p>	<p>Position the ball joint to the first position angled rearward and slide the ball joint 8.8mm from the outside.</p>
<p>This configuration roughly equates to the following changes over the OE UCA: Camber: -0.6 deg Caster: +1.9 deg</p>	<p>This configuration roughly equates to the following changes over the OE UCA: Camber: -0.9 deg Caster: +2.6 deg</p>

It is recommended that a licenced workshop or tradesperson carry out the above procedure and that workshop manual and relevant safety procedures are followed in addition to the above.