

Install Guide

Centre Bearing Spacer Kit

Ford Ranger, LDV T60, VW Amarok

Z7071-N
Page 1 of 1

Nolathane[®]

Note: These components must be fitted by a qualified person only, as per the manufacturers' service manual. Also, all relevant safety procedures are followed in addition to the following. Photos are an indication and may vary slightly in appearance from the actual product.

Kit Contents:

- 2 x M10 1.5Px50mm Bolt
- 2 x M10 Spring Washer
- 2 x M10 Flat Washer
- 4 x 8mm Spacer
- 2 x 4mm Spacer

This kit helps to reduce driveline vibration in a 2" lifted vehicle.

1. Remove original centre bearing fasteners.
2. Fit the kit as per picture below – 1 x 8mm and 1 x 4mm spacer on top, 1 x 8mm and the supplied fasteners on the bottom.

Note: image may not resemble vehicle in question and is for demonstration purpose

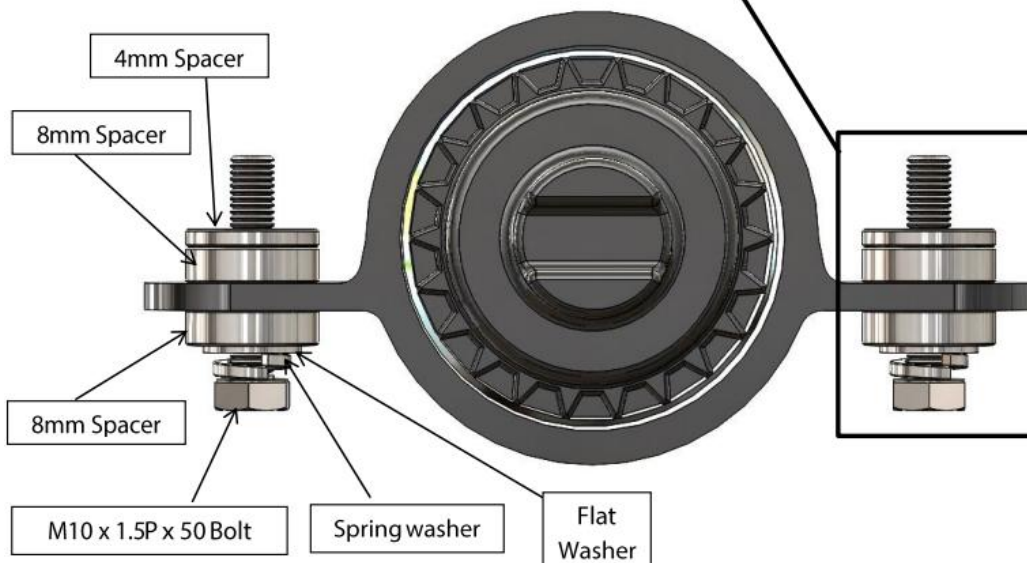
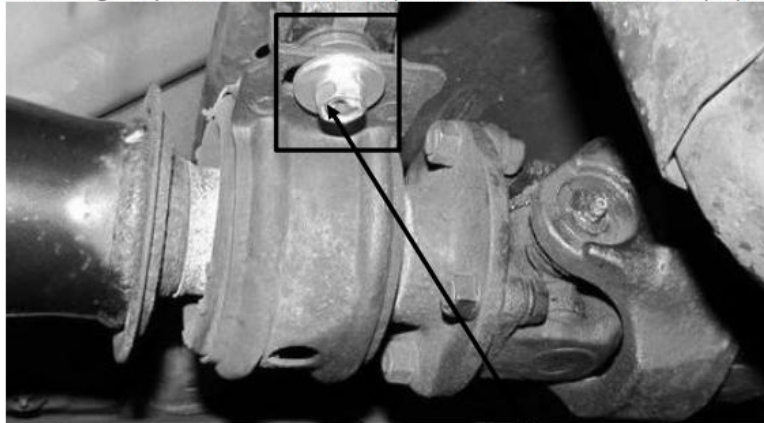

3. Drop Loctite on the thread and tighten the bolt to manufacturer's specification.
4. Test drive and adjust spacer position as required.