

Fitting Instructions #Z6302

Ford Ranger PX3

Front Lower Control Arm

Nolathane®

NOTE: These components must be fitted by qualified persons only, to factory specifications, as per factory service manual.

1. Before beginning any alignment work, always check for loose or worn parts, proper tyre pressures, and odd tyre wear patterns. Replace any loose or worn parts before setting alignment;
2. Raise vehicle by the chassis and support with jack stands. Remove front tyre and wheel assemblies;
3. Remove the factory front lower control arms and clean the chassis area.
 - Please note that the ball joint taper lock insert will come off together, use an insert puller tool to remove it from the factory control arm and **reuse with the new control arm.**



Remove and Reuse
Factory Ball Joint
Taper Lock
Insert/Sleeve

4. Install the control arms to the vehicle;
5. Use the supplied camber pins, shank coated with anti-seize, to tighten the arm onto the chassis (see camber bolt diagram for correct installation);
6. Re-install the tyre and wheel assembly. Lower the vehicle and take alignment readings. Adjust the camber pins to achieve the desired setting;
7. When final caster/camber settings are achieved, torque the camber pins assembly to 160 Nm and road test the vehicle.

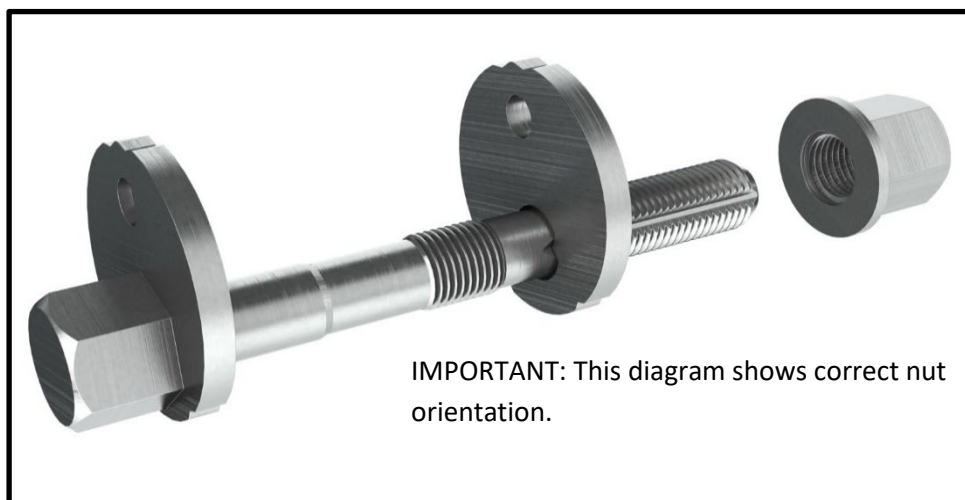

Camber Bolt installation diagram