

# Install Guide

## Rear Control Arm Upper and Lower – Inner Bush Kit (Offset)

### Nissan Patrol Y62 2010+

**Nolathane®**

**Note:** These components must be fitted by a qualified person only, as per the manufacturers' service manual. Also, all relevant safety procedures are followed in addition to the following. Photos are an indication and may vary slightly in appearance from the actual product.

#### Kit Contents:

- 4 x SPF4128 Bush
- 4 x Offset Tube 32x14.3x73.5

**NOTE:** Polyurethane bushings must be fitted to both sides of the vehicle.

1. Wheel align vehicle before commencement of work and note settings.
2. With vehicle on hoist or on jack stands, remove the control arms.
3. Remove the original bushes including the steel shell.
4. Apply the grease supplied to the control arm housing and the outside surface of the bush.
5. Using the appropriate pressing tools, support the control arm and press the new '4128' bushes in the arm housing. Note the orientation of the bush to be pressed in the control arm housing. Refer to: Figure 3 for the Rear Upper Control Arm bush kit installation; Figure 4 for the Rear Lower Control Arm bush kit installation.

Note: use a flat plate to cover all the surface of the end of the bush to press the shell in the housing.

6. Apply the grease supplied to the bore of the bush and the outside surface of the steel crush tubes, then push the crush tubes in the bush. Note: Tubes Must be pressed in correct orientation for appropriate alignment correction. Refer to Figure 1 and 2 for orientation of the crush tube in the bush.
7. Refit the control arms to the vehicle and tighten the bolts to manufacture's torque settings.
8. Reassemble the rest of the vehicle and carry out wheel alignment.

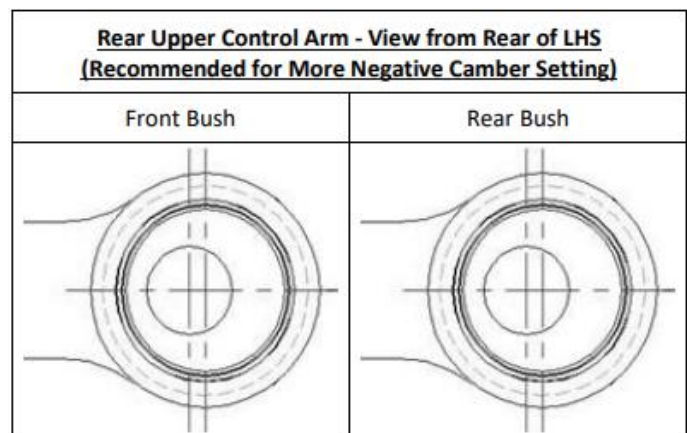

Figure 1: LHS Rear Upper Control Arm (Rear View)

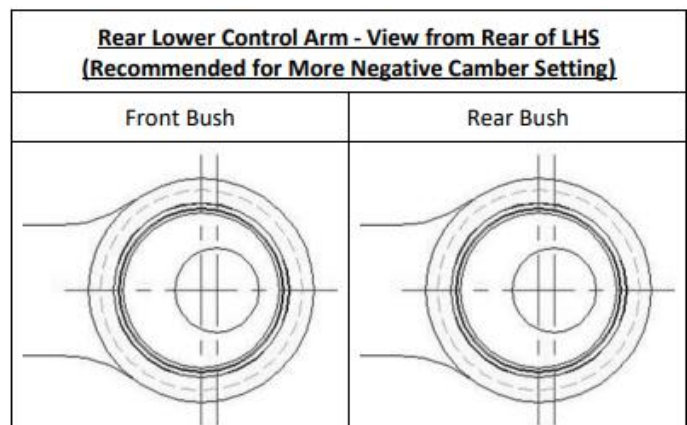

Figure 2: LHS Rear Lower Control Arm (Rear View)



# Install Guide

## Rear Control Arm Upper and Lower – Inner Bush Kit (Offset)

### Nissan Patrol Y62 2010+

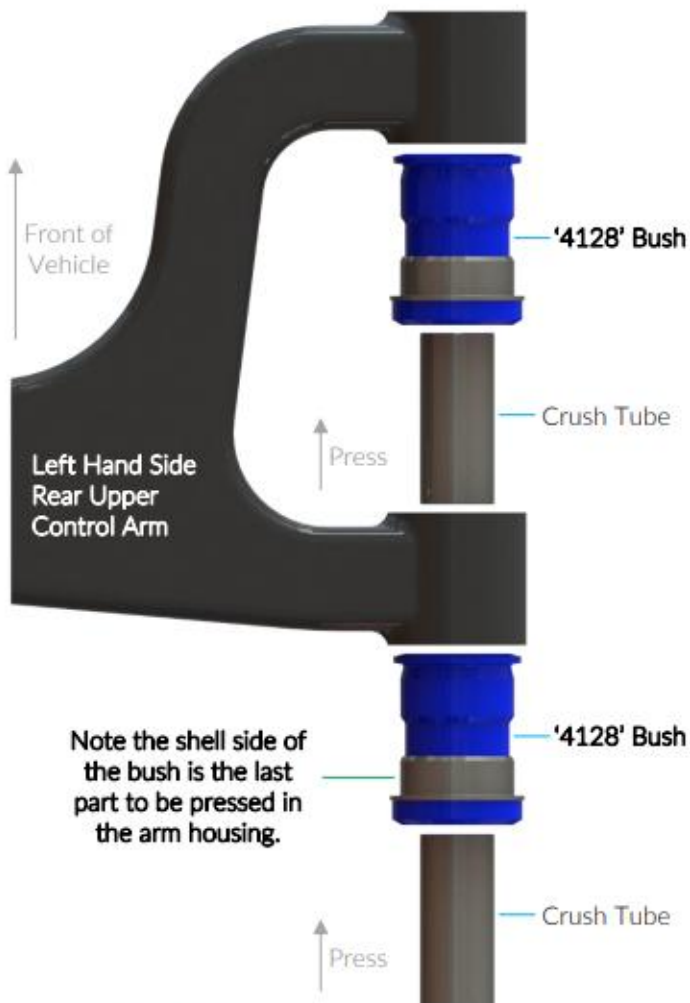

Figure 3: LHS Rear Upper Control Arm Bushing (Top View)

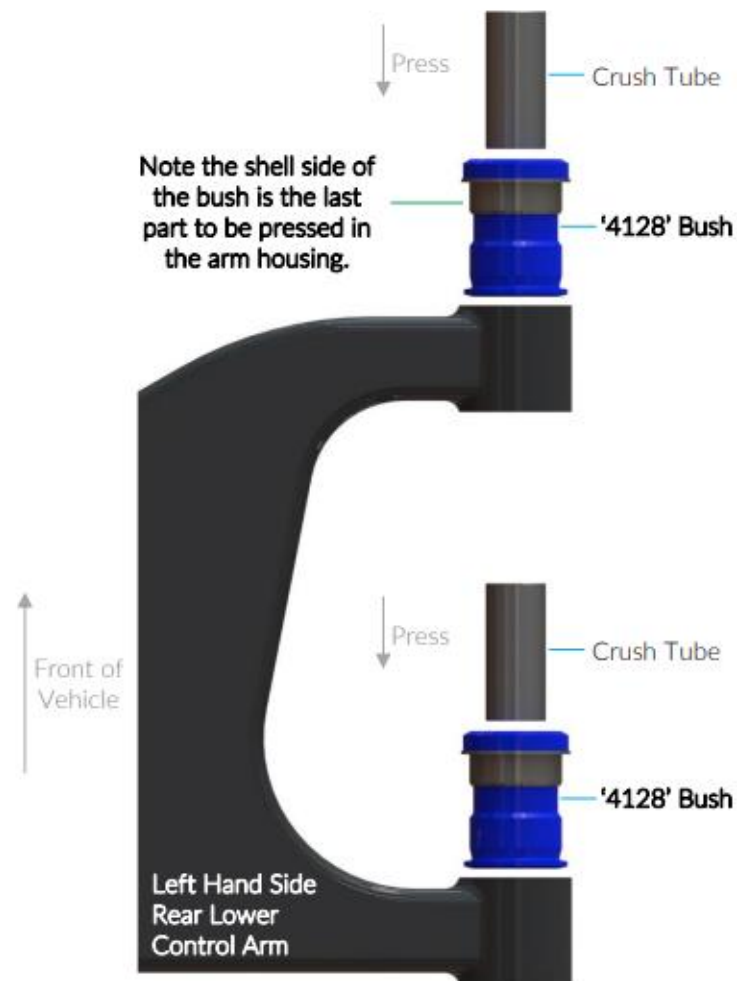

Figure 4: LHS Rear Lower Control Arm Bushing (Top View)