

Instructions

Upper Trailing Arm Bushings

This instruction sheet should be used in conjunction with workshop manual and proper safety precautions followed



Application - Jeep Cherokee XJ
 - Jeep Wrangler TJ
 - Jeep Grand Cherokee ZG-WJ

Contents - bushing 2842 x4
 - steel tubes 19x10.3x51mm x4
 - grease

- Raise vehicle evenly and safely support.

Never rely on a jack only

IMPORTANT - DO NOT REMOVE/PRESS OUT ORIGINAL STEEL OUTER SHELL

- Start by removing just 1 arm (it is recommended only 1 arm be serviced at a time).
- The old rubber will need to be removed. Use heat to heat up the inner steel tube - to delaminate the bond from both the inner tube and outer shell.
- Clean up the rubber completely - making sure the outer shell (still in arm) is clean.
- Press new supplied bushing into the factory shell. Using soapy water and flat surfaces to help.
- Grease bushing internal diameters with supplied grease only
- Grease bushing side face also.
- Push in supplied steel tube.
- Re-fit arm to vehicle.
- Repeat to other side.
- Road test. Re-check all bolts after 200kms

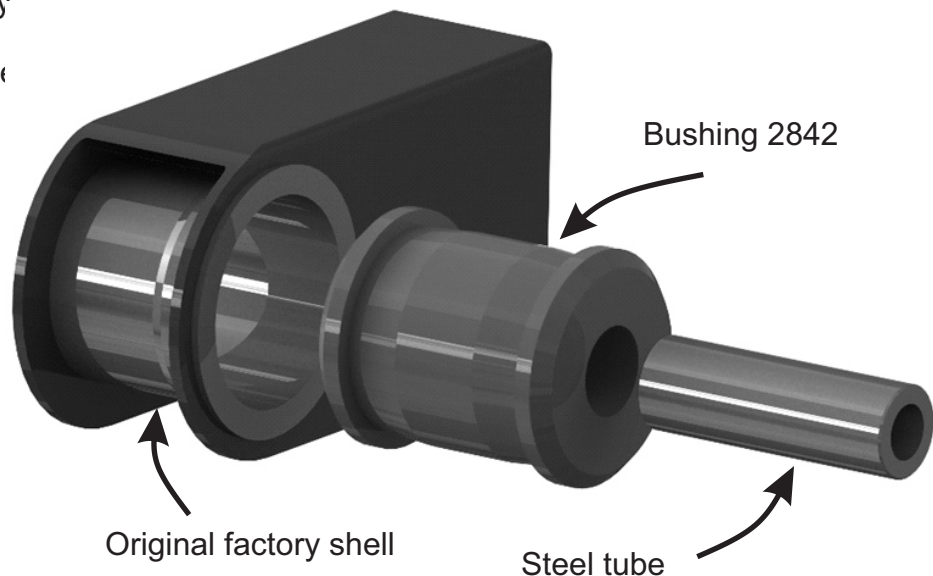

It is recommended that a licenced workshop or tradesperson carry out the above procedure and that workshop manual and relevant safety procedures are followed in addition to the above.