

Central Locking Fitting Instructions For HardLid

ARB New Zealand	
Kit #	10058061
Instruction #	10058107



4X4 ACCESSORIES

Central Locking Fitting Instructions for HardLid

READ INSTRUCTIONS CAREFULLY BEFORE COMMENCING THIS ACTIVITY.

1. Install all electrical components first (1 of 3) (electrical components are supplied seperately)
2. Install Vehicle Tub Sealing Kit (2 of 3)
3. Install vehicle tub protective products such as tub liners*
4. Install styling bar onto HardLid
5. Install the HardLid Fitting Kit (3 of 3)
6. Install the HardLid (3 of 3)
7. Install any additional accessories such as roof racks.

**HardLid is compatible with under rail and Sport Guard style tub liners. Some trimming may be required. OEM liner compatibility cannot be guaranteed. Please contact your dealer for more information.*

- HardLid is supplied with 400N Gas Struts which are suitable for an unloaded lid. Recommended maximum loading of 25 kgs when opening the lid. If you require your lid to remain open whilst loaded, you will need to purchase a Heavy Load Strut Upgrade Kit which is available through your local dealer. Please use one of the following part numbers as a reference when contacting your dealer:

ARB NZ Part #	ARB AU Part #	Gas Strut N	
10056207	176202	450N	
10056209	176201	500N	

- Read through the fitting instructions before installation of accessory.
- Check that the contents of the Fitting Kit are complete and undamaged.
- If any contents of the Fitting Kit are found incomplete or damaged they must be replaced using the specified accessory components.
- Always install the accessory following the fitting instructions. Failure to do so may cause damage to the vehicle or the accessory and void the warranty.
- Ensure all recyclable discarded vehicle/accessory components and packaging are disposed following local recycling regulations.
- Safely store and protect any removed vehicle components.
- Ensure all bare metal surfaces are protected using Automotive Bare Metal Primer and touch-up paint.
- Remove all metal swarf and dust from all vehicle surfaces.
- Ensure all fasteners are torqued to the specifications as per instruction.
- Apply any adhesives to the vehicle only when the surface temperature is between 20°C to 40°C.
- **Bedliner:** Recommended rust preventative solution be applied to vehicle surfaces before installation.

General Vehicle and Accessory Warranty Notes and Cautions

- For correct installation and proper operation of the vehicle and accessory we recommend this accessory is fitted by a qualified Technician.
- During the accessory fitment ensure all automotive safety practices and regulations are followed.
- Do not modify the vehicle in any way other than specified in these Accessory Fitting Instructions as this may void the warranty.



Safety Notes

- Check that all work practises comply with safety standards.
- It is advisable to seek assistance from another person when lifting heavy components.
- While using power tools ensure safe procedures are followed.
- Appropriate clothing & PPE must be worn.

Central Locking Fitting Instructions for HardLid

READ INSTRUCTIONS CAREFULLY BEFORE COMMENCING THIS ACTIVITY.

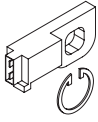
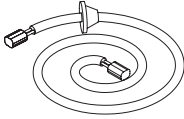
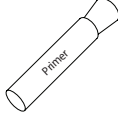
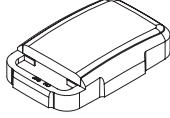
Kit Contents- Hardware

No.	Item Description	Quantity	Image	Part Number
1	LOCKING MODULE & CIRCLIP	1		10055335
2	UNIVERSAL LID LOOM	1		10055529
3	SURFACE PRIMER	1		10051996
4	DOME LAMP & BATTERIES	1		10052791
5	ALCOHOL WIPES	1		10051664

Tools Required

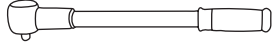
No.	Description	Image	No.	Description	Image
1	Metric Hex Key Set		2	Torque Wrench	

Central Locking Fitting Instructions for HardLid

READ INSTRUCTIONS CAREFULLY BEFORE COMMENCING THIS ACTIVITY.

Step 1

- This instruction is only for the installation of central locking components into the HardLid. Additional components and instructions are required for vehicle patch harness installation. Please refer to the Table 1 for vehicle specific kits.

TABLE 1	
Ford Ranger 22+	10057994
Isuzu D Max 20+	10057996
Mazda BT50 20+	10057996
Nissan Navara 21+	10057995
Toyota Hilux 15+	10057993

Step 2

- Place the lid upside down on a flat surface.
- Remove the service cover by extracting 8 X M6 button head screws.
- Ensure the Emergency Exit Handle is detached from the Velcro pad before removing the cover.

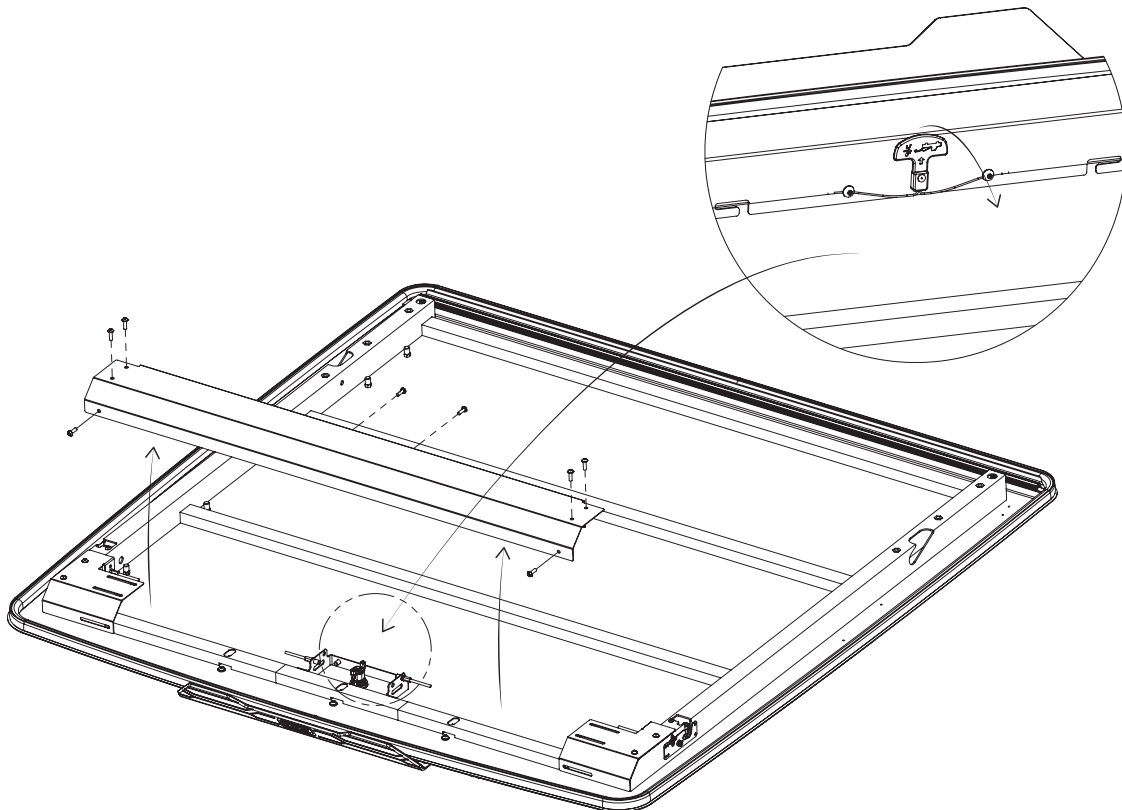

Central Locking Fitting Instructions for HardLid

READ INSTRUCTIONS CAREFULLY BEFORE COMMENCING THIS ACTIVITY.

Step 3

- Refer to Table 2 for loom location based on vehicle model.

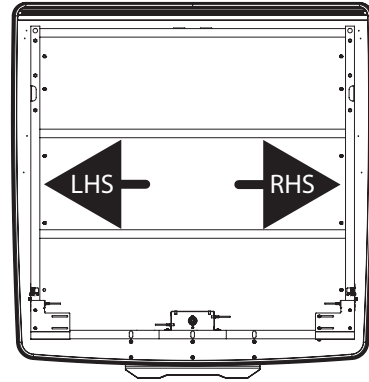
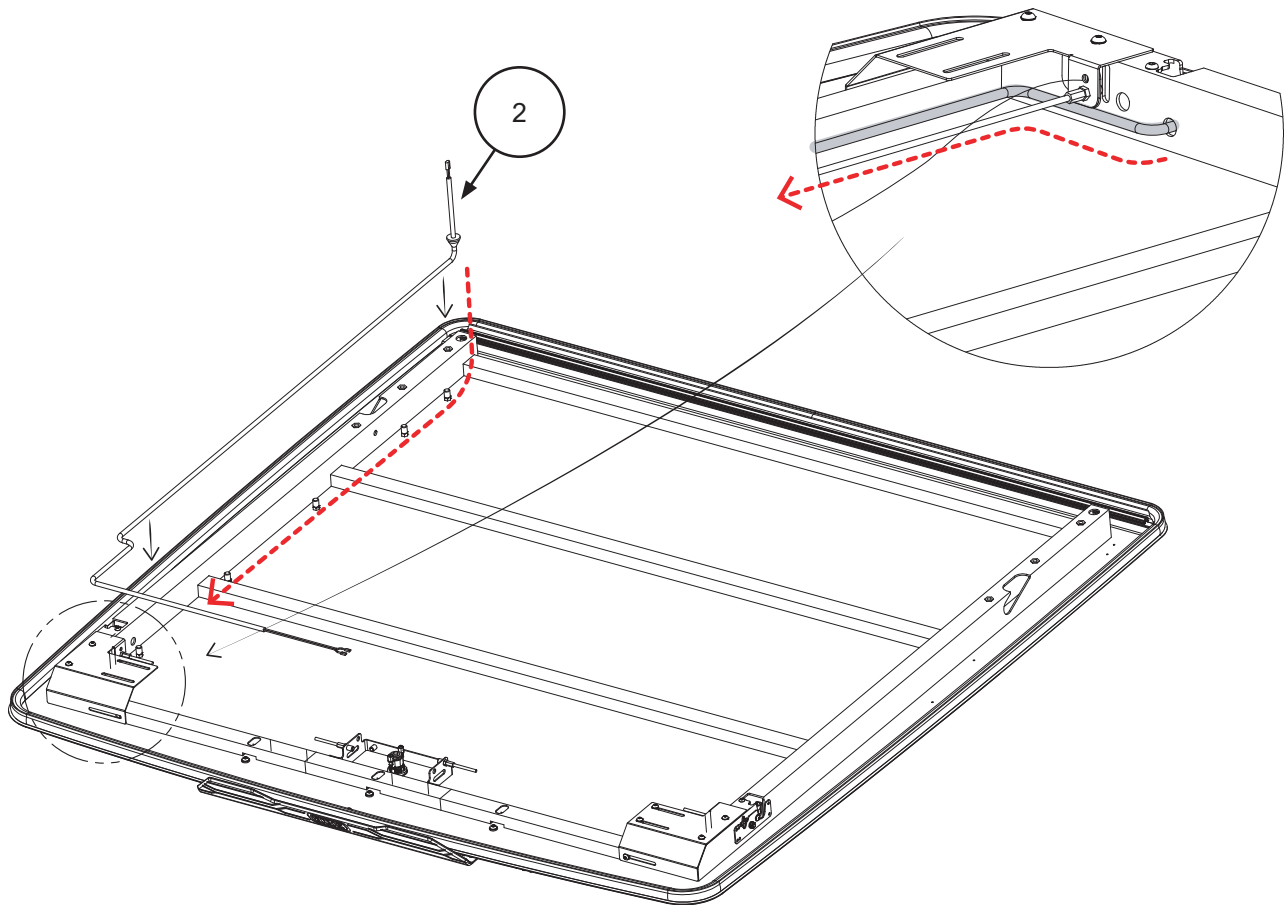

TABLE 2

Ford Ranger 22+	Right hand side (RHS)
Isuzu D Max 20+	Left hand side (LHS)
Mazda BT50 20+	Left hand side (LHS)
Nissan Navara 21+	Left hand side (LHS)
Toyota Hilux 15+	Left hand side (LHS)

Step 4

- Insert the central locking loom (2) into the large hole at the front of the frame.
- Run the loom down the length of the frame and out of the hole preceding the latch.
- Ensure the loom sits above the latching cables.



Central Locking Fitting Instructions for HardLid

READ INSTRUCTIONS CAREFULLY BEFORE COMMENCING THIS ACTIVITY.

Step 5

- Remove the screw, washers and locking cable assembly from the central lock.

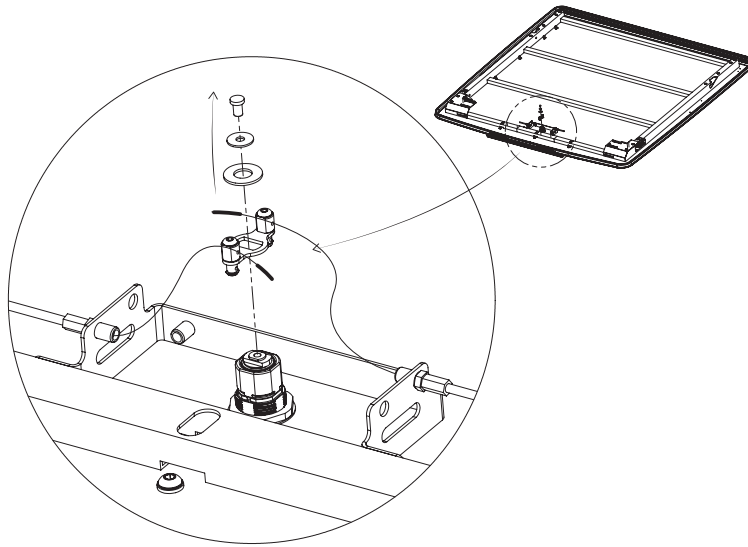

Step 6

- Install the locking module and cir-clip (1). Ensure the locking module connectors are facing toward the left hand side of the lid. Reinstall the screw, washers & locking cable assembly. Torque to **4NM**.

IMPORTANT: Perform a manual unlocking test by twisting the lock handle. This is to ensure the cables have been reinstalled in the correct orientation.

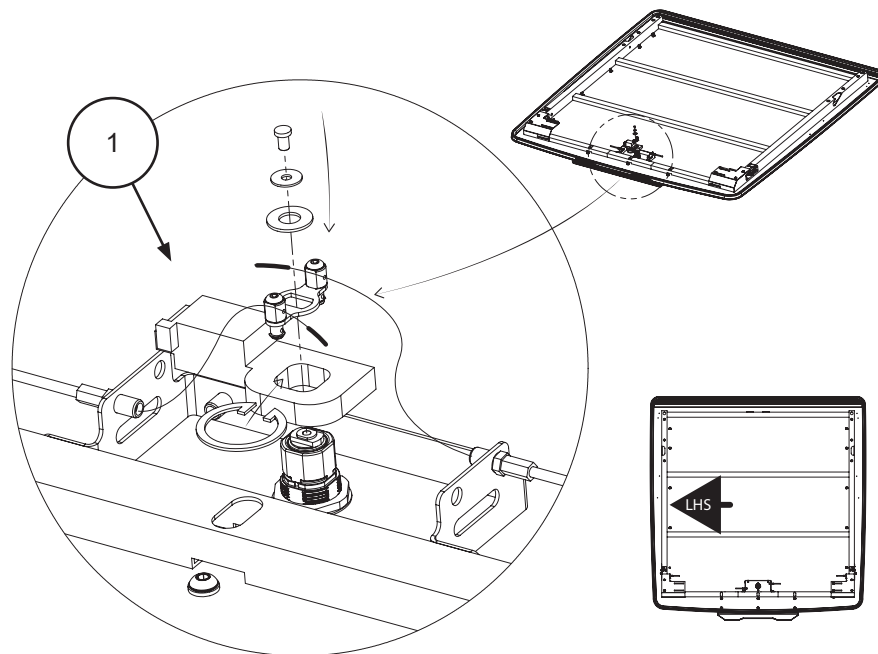

Central Locking Fitting Instructions for HardLid

READ INSTRUCTIONS CAREFULLY BEFORE COMMENCING THIS ACTIVITY.

Step 7

- Plug spade terminals onto locking module as shown.
GREEN = Lock - Indicated by 'L' on the module
BLUE = Unlock - Indicated by 'U' on the module.

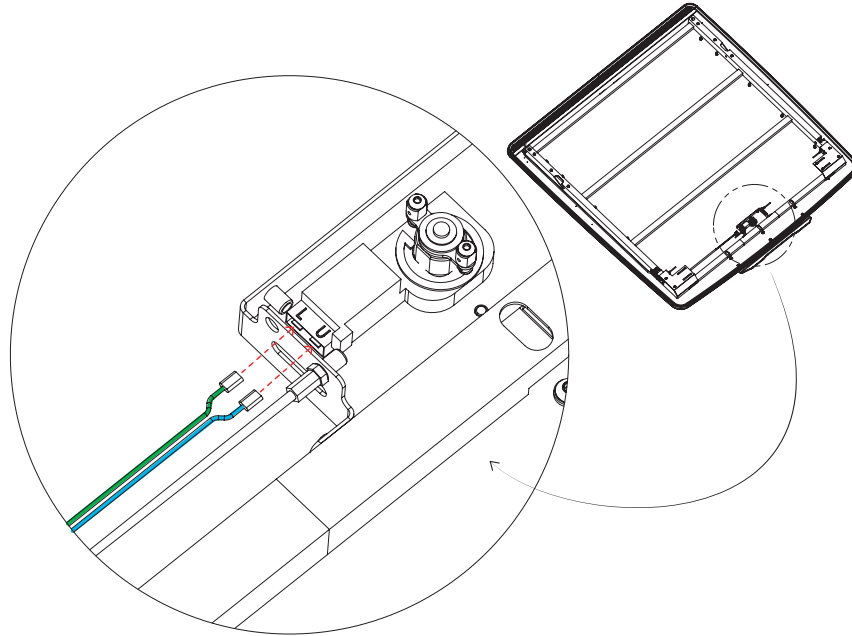

Step 8

- Reinstall the service cover. Torque fasteners to **6NM**. Ensure all cables are re-routed correctly and operate smoothly.
- Latching cables are routed through outer slots only.
- Emergency exit cables are routed through inner and outer slots.

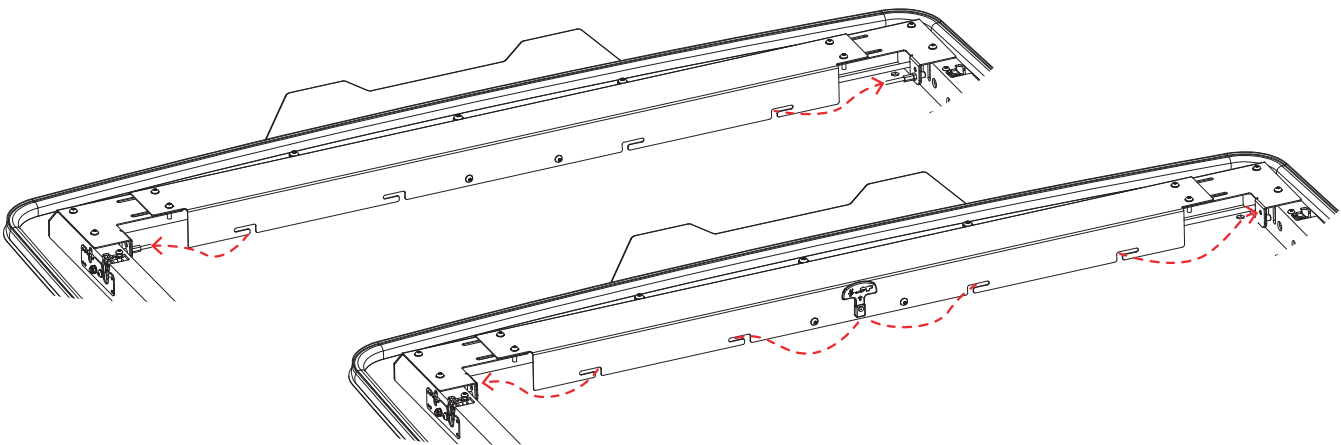

Central Locking Fitting Instructions for HardLid

READ INSTRUCTIONS CAREFULLY BEFORE COMMENCING THIS ACTIVITY.

Step 9

- At the centre of the HardLid, measure backward from the service cover 90-95mm.
- Clean and prime the surface using the alcohol wipes (5) and surface primer (3).
- Remove the backing strips from the dome lamp (4), stick the dome lamp into position with the on/off switch facing toward the rear of the vehicle.

