

FITTING INSTRUCTIONS

Document Title:

FI-290

Application:Ford Ranger MY22
Ford Everest MY22**Model Number:****StealthBar**SA290AA290 Standard / Non-Parking Sensor
SA290AA291 Winch / Non-Parking Sensor
SA292AA290 Standard / Parking Sensor
SA292AA291 Winch / Parking sensor**Fitting Time:**

Minimum 4.5 Hours

Revision:

H (27 October 2022)

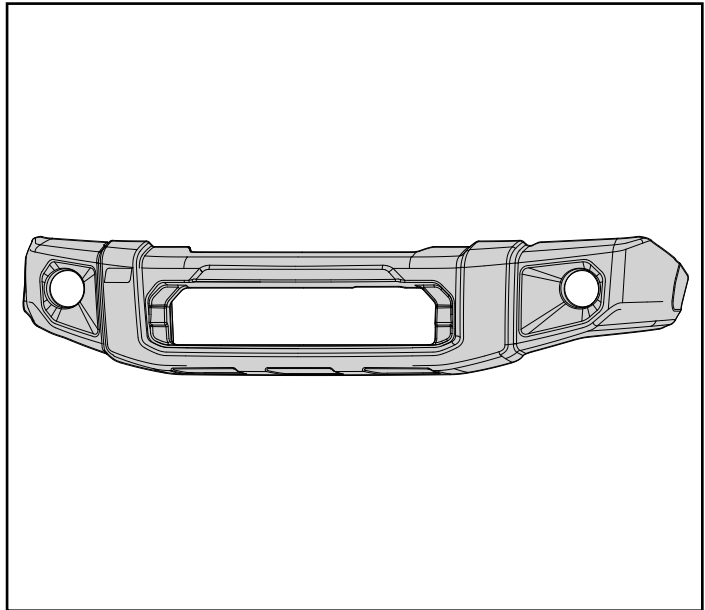

Congratulations on your purchase of a StealthBar.

Additional Kits:

-SA290CRK (Camera Housing/Radar Kit) 30 min.
-SA290RHK (Radar Housing Kit) 15 min.
-SA290FLK (Fog Light Kit) 30 min.

-SA290ALK (Aerial Mount Left Kit) 5 min.
-SA290ARK (Aerial Mount Right Kit) 5 min.
-SAHLJ1 (High Lift Jack Point) N/A

Warning:

- Do not attach VFPS to the vehicle using anchorages not intended for this purpose (e.g. engine mounting bolts).
- Do not use this product for any vehicle make or model, other than those specified by the VFPS manufacturer.
- Do not remove the plaque or label from the VFPS (StealthBar).
- Do not modify the structure of the VFPS in any way.

Note:

- Left and Right hand sides of the vehicle and StealthBar are from the view of being in the drivers seat looking forward.
- Please take the time to read the instructions thoroughly before proceeding with fitment of the StealthBar.
- Ensure all components, as listed in the bill of materials on the back page, are received prior to commencing the fitment. Please retain all hardware until fit-up is complete.
- All wiring should be completed by a qualified auto electrician. SmartBar bears no responsibility for any electrical failure caused by the incorrect fitment of the lamps.
- Ensure these fitting instructions are passed onto the vehicle owner and/or operator.
- We recommend the **use of anti-seize on all threaded fittings.**



CAUTION A torque specification is required for the bolts into the StealthBar nutserts. THESE MUST NOT BE OVERTIGHTENED.

Tools Required

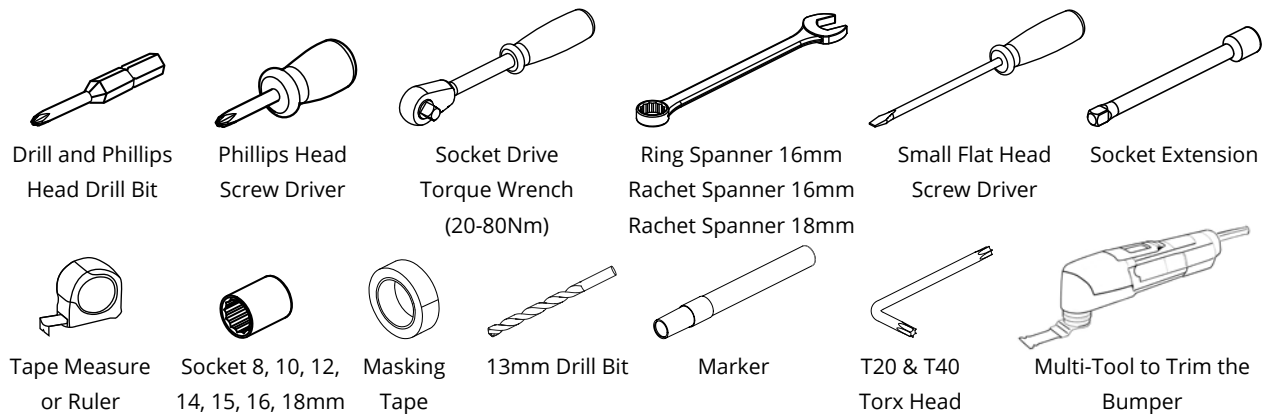

SmartBar and Mounting Brackets Overview - SA290BK/SA291BK

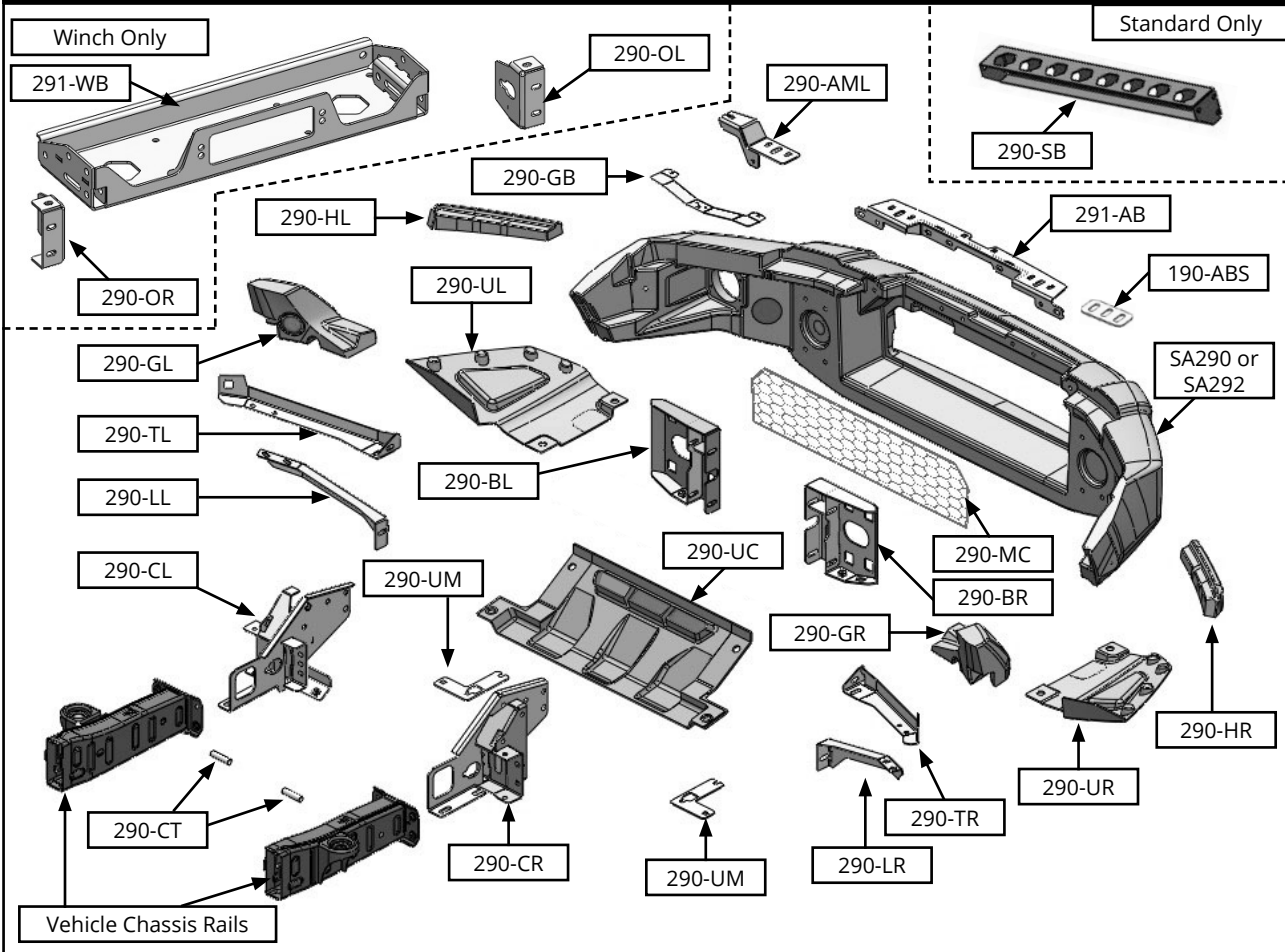

Torque Specs (into SmartBar Nutserts)

Bolt Size	Torque (Nm)	Torque (lb/ft)
M10	28	20
M12	55	40

Torque Specs (Metal to Metal Mounts)

Bolt Size	Torque (Nm)	Torque (lb/ft)
M10	44	32
M12	78	57

Step 1: Vehicle Disassembly

Note: Do not discard removed hardware and components until the installation is complete.

1.1 Remove Scrivets shown to remove the top cover from the vehicle.

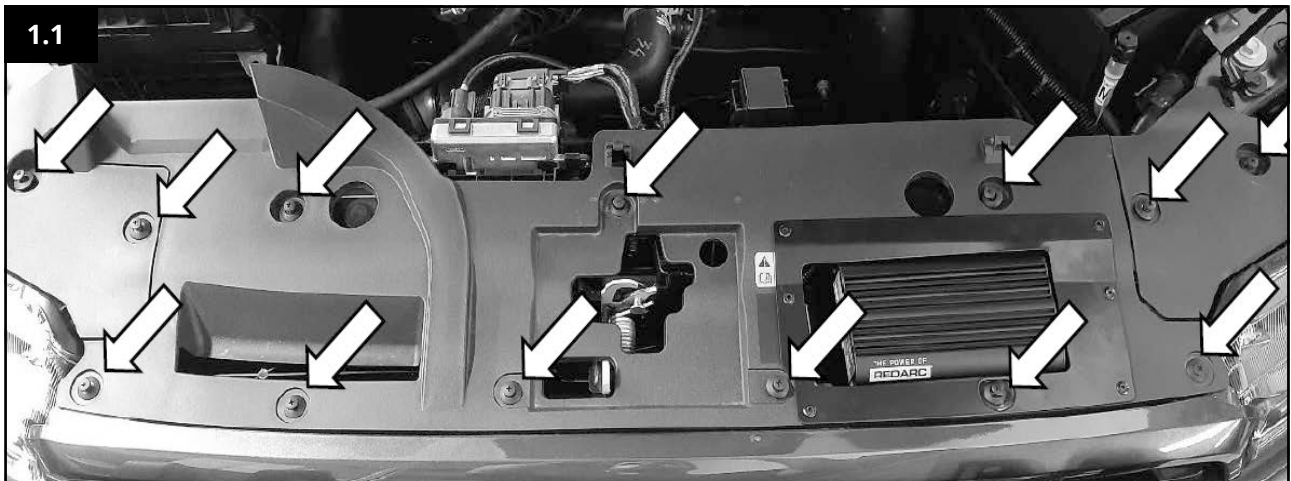

1.2 Remove number plate and number plate retainer from the vehicle.

Note: Keep the number plate in a safe and secure place for re-installation.

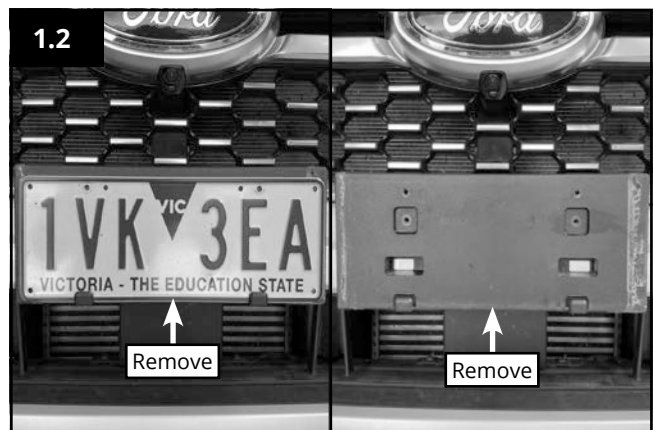

1.3 Remove bolt under the bumper.

Repeat on the other side.

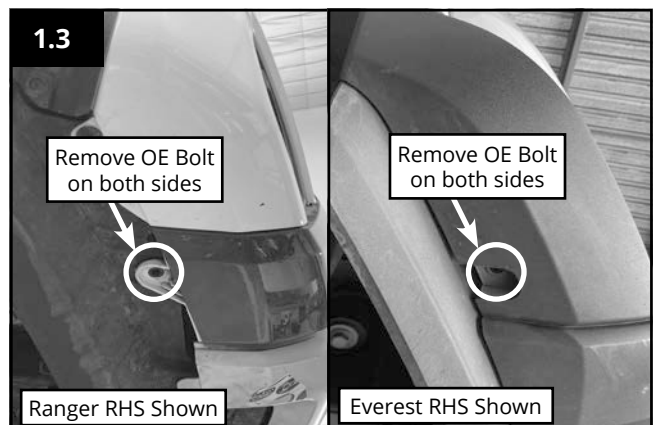

1.4 Remove front skid pan by removing bolts shown.

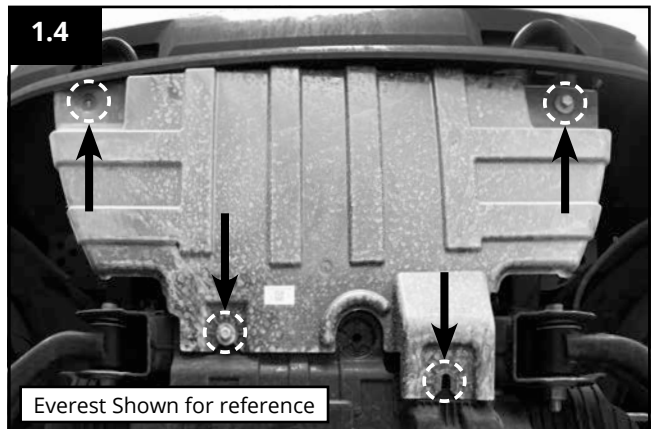

1.5 Remove the top 2 bolts that secure the grille to the vehicle.

Repeat on other side.

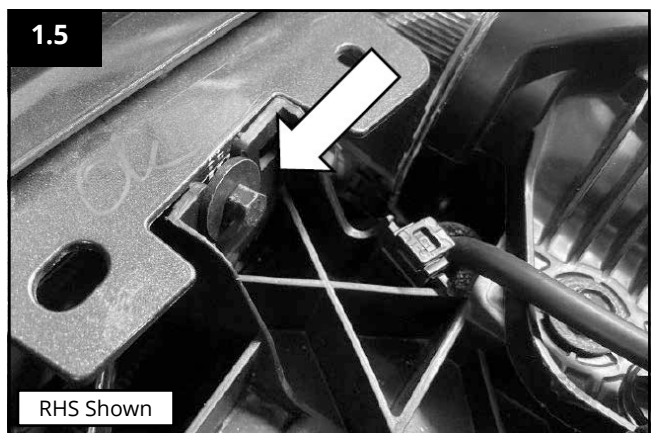

1.6 Gently unclip and remove Grille from vehicle.

Note: Set grille aside on a soft surface to avoid damage.



1.7 If present, disconnect main grey connector plug on top of the grille & unclip harness from vehicle.

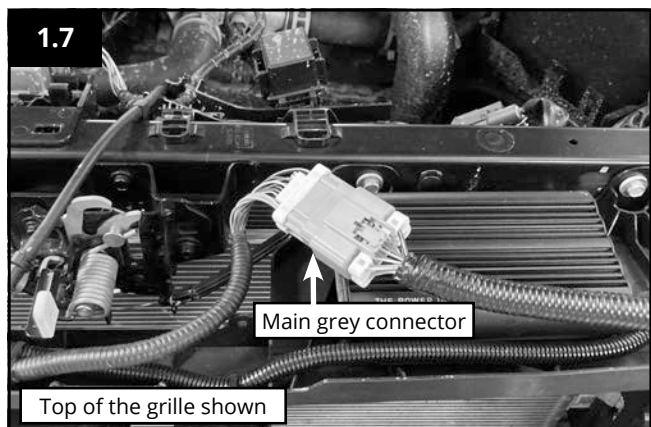

1.8 If vehicle is equipped with front camera, disconnect the coax camera cable, and camera washer hose from the car.

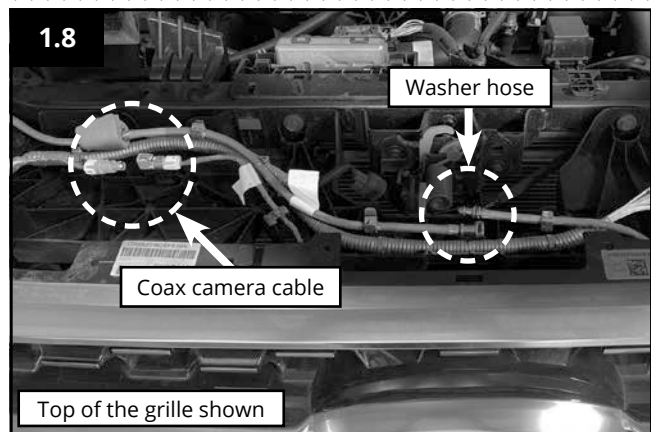

1.9 Check if the scale on the trim template is correct. If not, contact your nearest ARB store.

Cut the bumper trim template out.

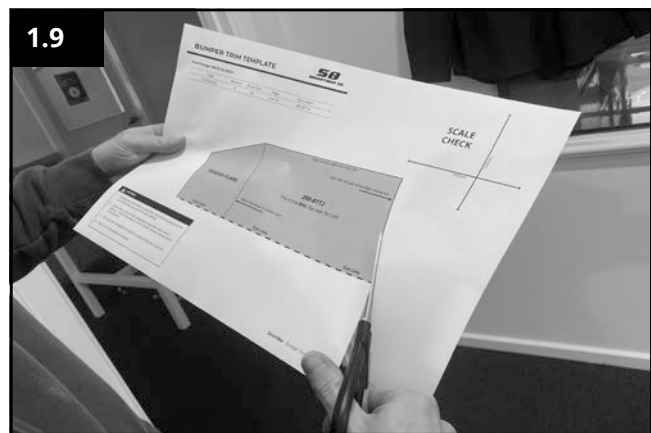

1.10 Cover area with masking tape. Align the bumper trim template to the vehicle. Mark trim line as shown.

Cut along marked line, and with side cutters, to cut the remaining bumper, 10mm next to light.

Repeat on the other side.

⚠ Do not damage the headlights.

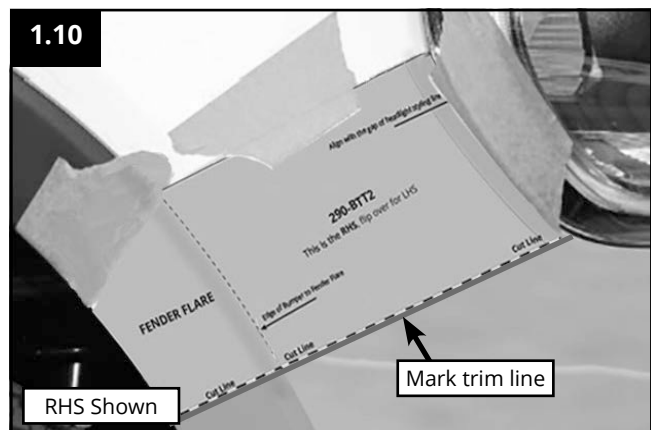

1.11 Remove lower wheel flare offcuts to access scrivets underneath and remove.

Repeat on right hand side.

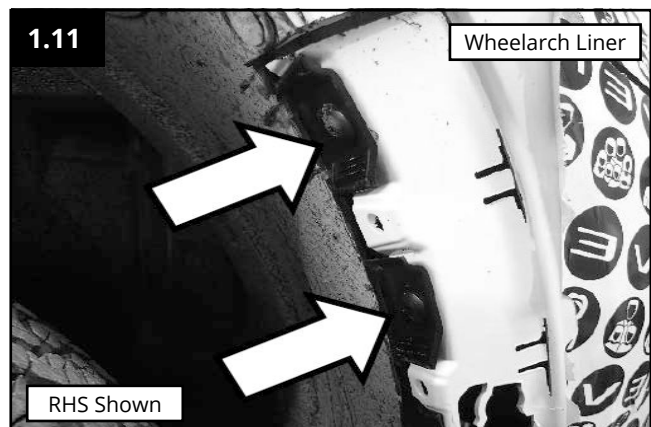

1.12 Remove the lower part of the trimmed bumper from the vehicle.

Note: Ensure that all wiring and hardware has been disconnected from the vehicle.



1.13 **Label** and remove parking sensor/fog light harness from the vehicle.

Note: Sensors must be labelled correctly to successfully re-install later.

LO	Left Outer	RO	Right Outer
LM	Left Middle	RM	Right Middle
LI	Left Inner	RI	Right Inner



1.14 Remove foam impact absorber from chassis.

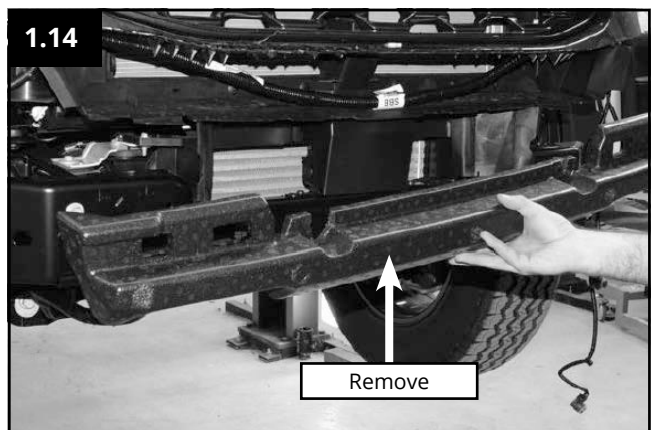

1.15 Remove Tape from previous steps.

Pull wheelarch flare back from the bumper trim and cut 10mm up from the trimmed edge as shown

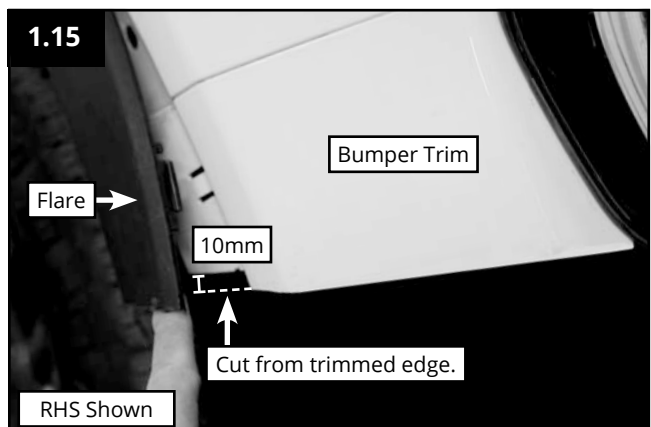

1.16 Apply pinch weld to bumper and flare.
Trim away excess pinch weld as shown.

Note: Recommended to cut 2cm section on the back of the pinch weld, as shown.

Repeat on right hand side.

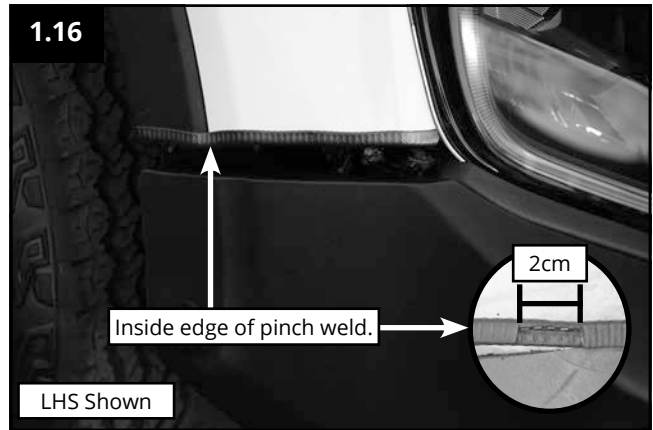
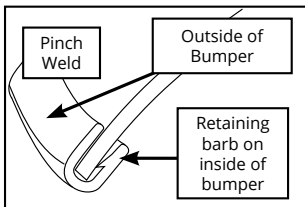

1.17 Locate the radar wiring loom near the Left hand side of the vehicle's intercooler and unclip the christmas tree clips.

This will allow the slack required to fit the sensor to the Bar.

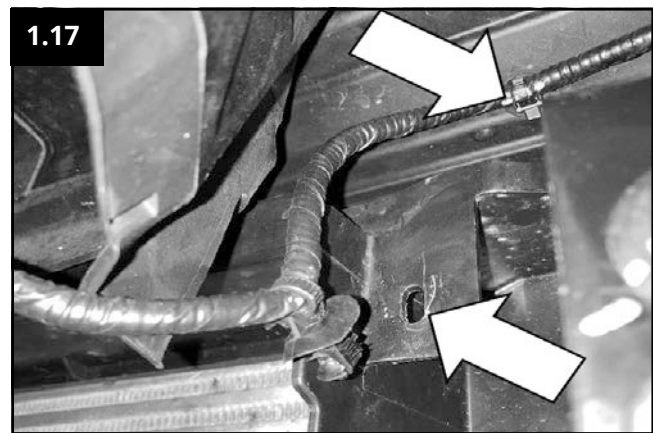

1.18 Remove scrivenets and black plastic cover from radar module.

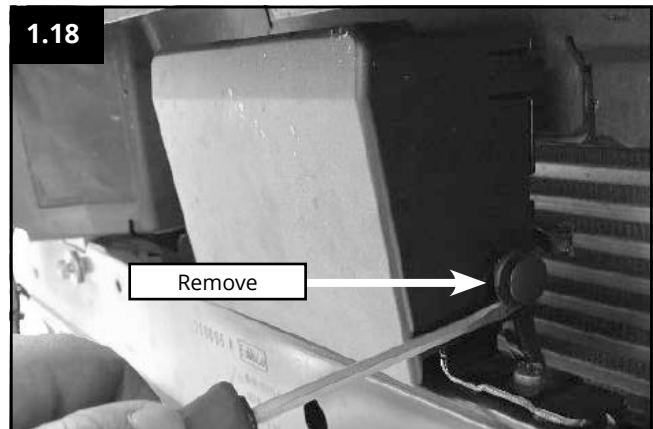

1.19 Disconnect radar wiring.

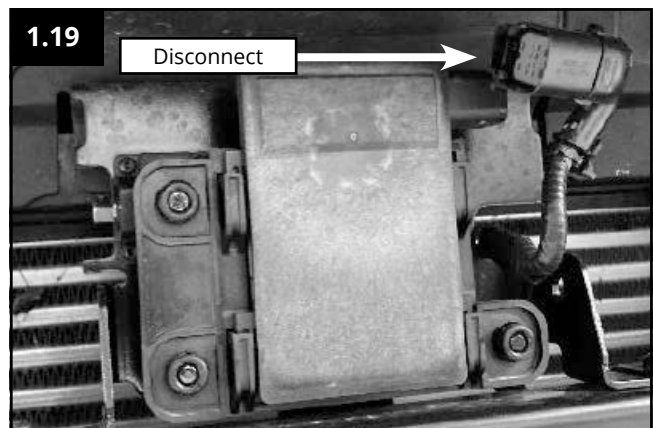

1.20 Remove radar from bracket by gently unclipping radar from ball point mounts as shown.

! DO NOT DAMAGE THE RADAR

Note: Store radar in a safe and safe place for re-installation.

1.21 Remove from crash beam from the vehicle.

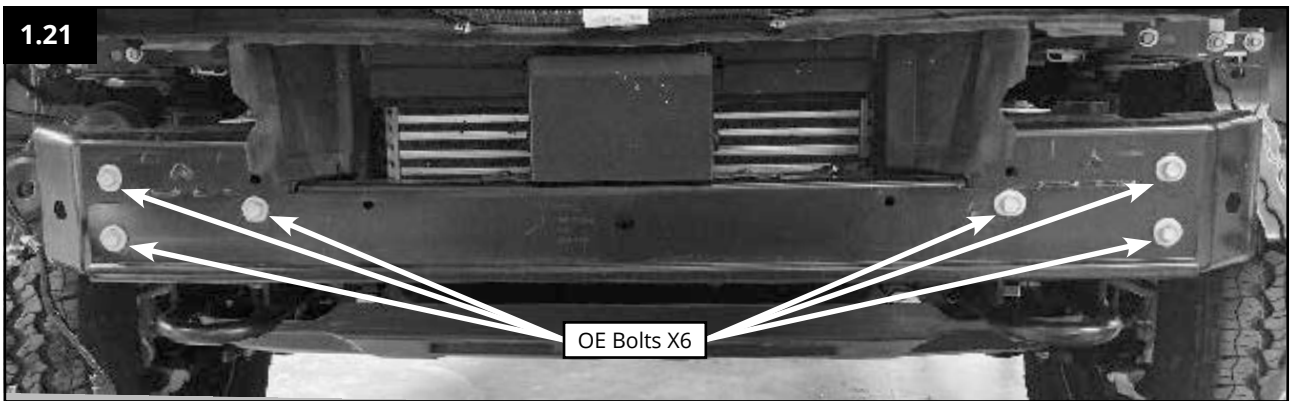
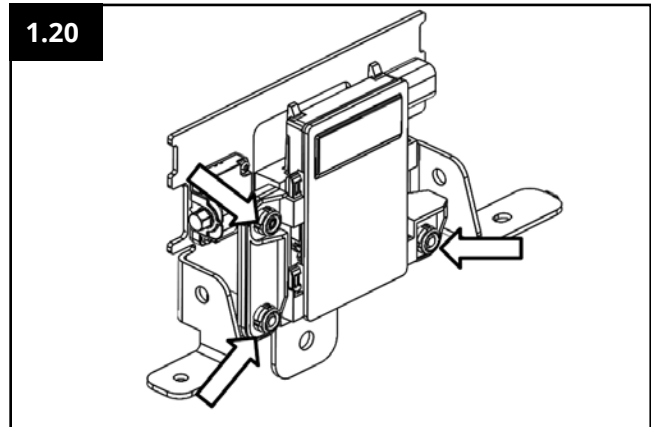

1.22a Cut the OE radar bracket as shown.

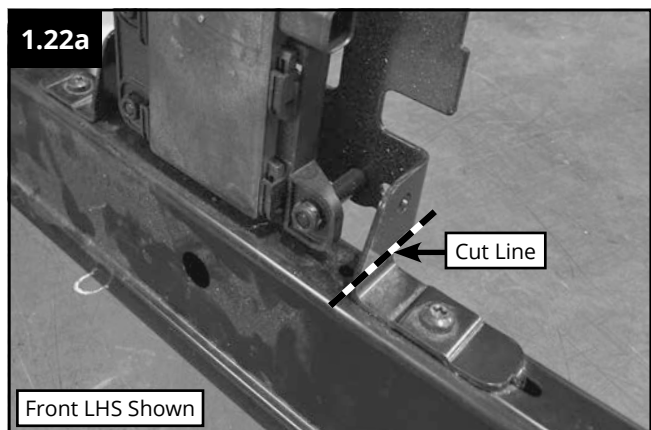

1.22b Cut the OE radar bracket as shown.

Discard the crash beam

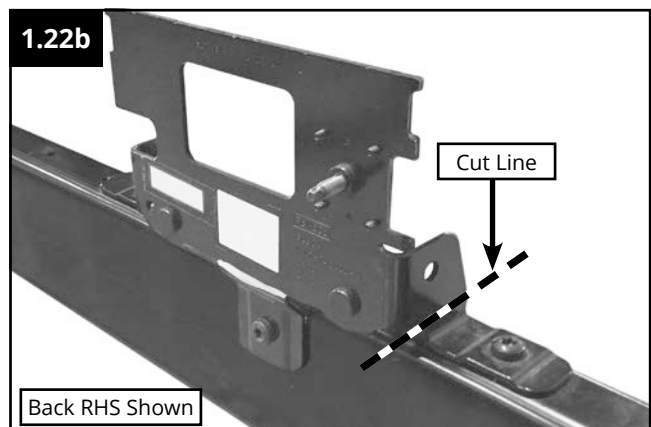

1.22c Cut the OE radar bracket off the crash beam along the cut lines shown.

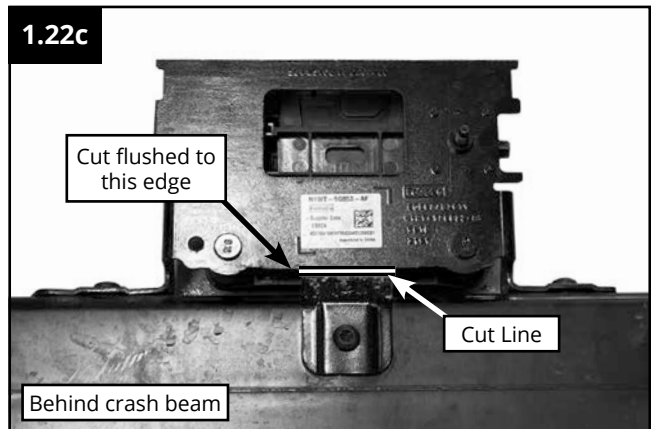

1.23 The cut radar bracket should now appear as shown.

Touch up the cut surface with rust preventative paint (not supplied).

Put the cut bracket aside for re-installation in later steps.

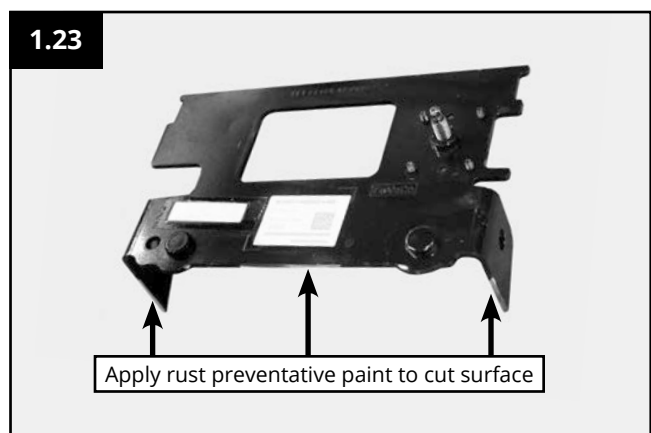

Winch Kit Only

1.24 Trim the front of the centre grille support mount.

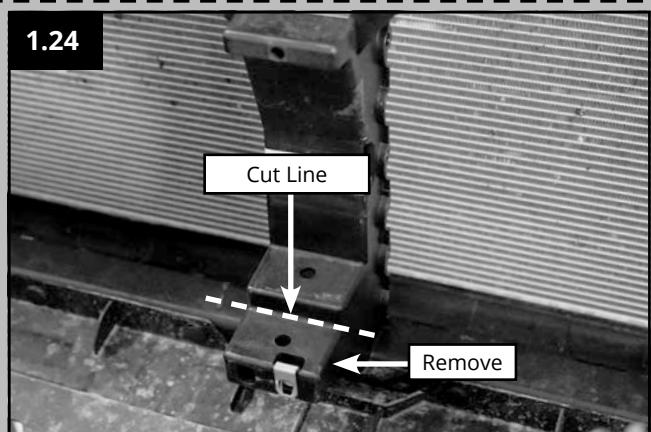
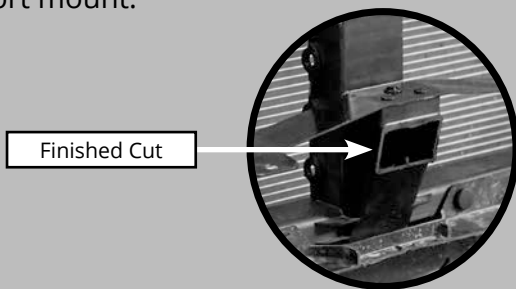

Ford Ranger MY22 Only

1.25a Measure, mark and drill a 6mm diameter hole in the lower intercooler brackets, 8mm above the original hole.

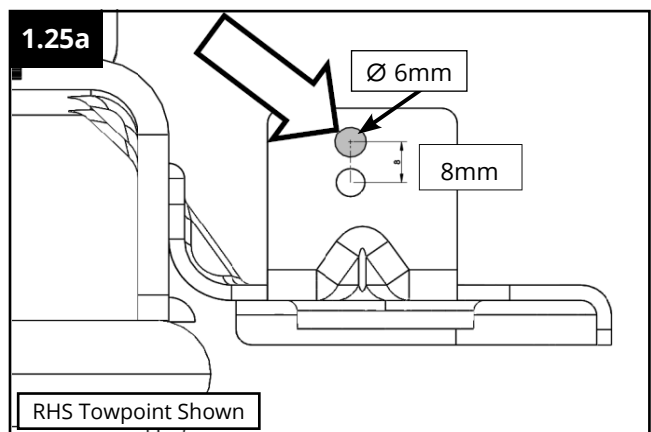

Ford Everest MY22 Only

1.25b Measure, mark and drill a hole in the lower slot of the intercooler cover as shown.

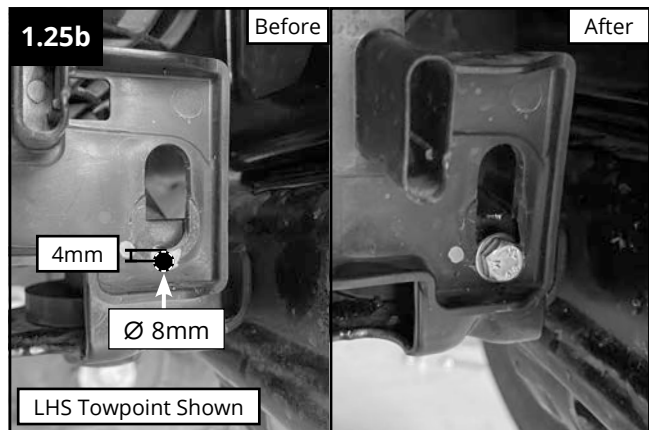

1.26 Cut Airdam as shown and repeat on left hand side.

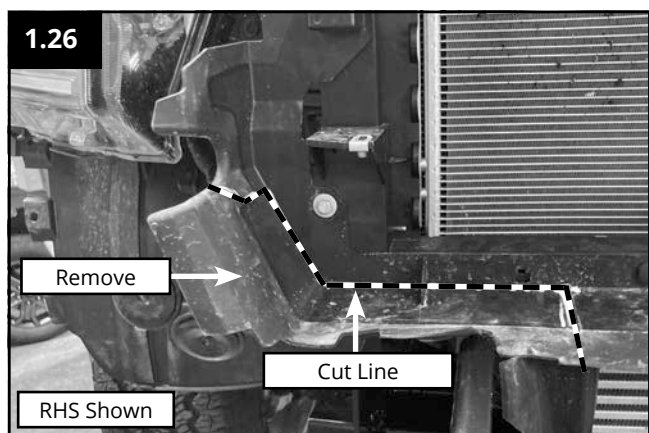
**Winch Kit Only**

1.27 Trim front of radiator air dam.

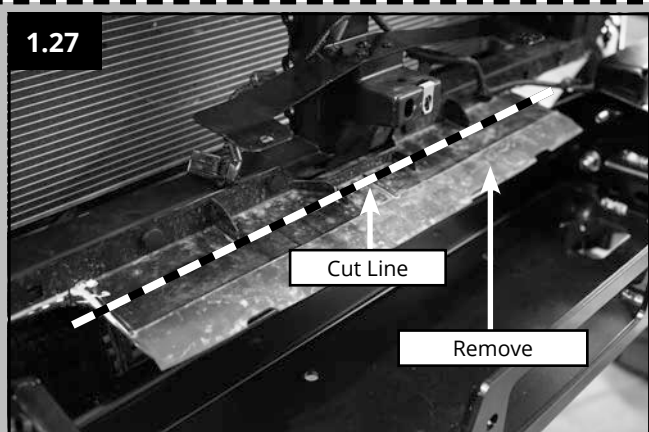
**Ford Ranger MY22 Only**

1.28 Loosen the horn retaining brackets and relocate to clear the wing brackets as shown.

Re-tighten to **9Nm**.

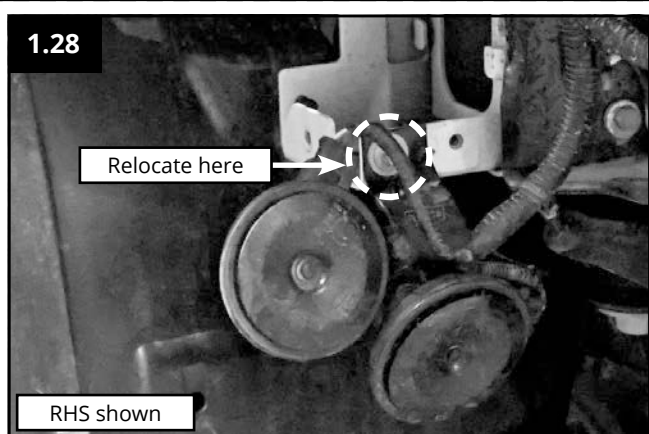

1.29 Remove Tow Points from vehicle.

Repeat on right hand side.

Note: Using a transmission jack or similar, support the intercooler.

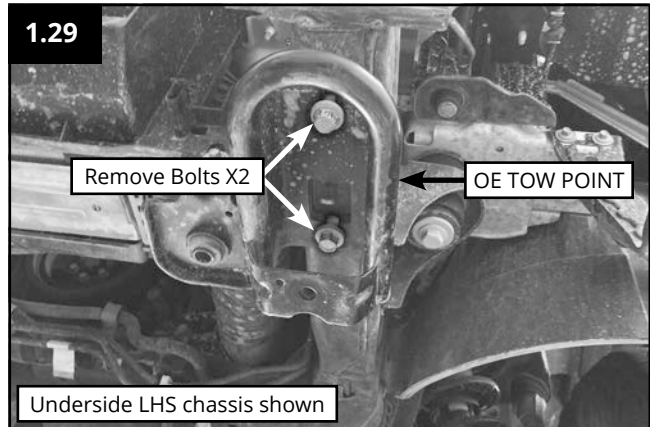

If installing recovery point skip this step and refer to step 2.5.

1.30 If not installing an ARB Recovery Point, remove original rubber grommets from the base of the intercooler.

Repeat on the left hand side.

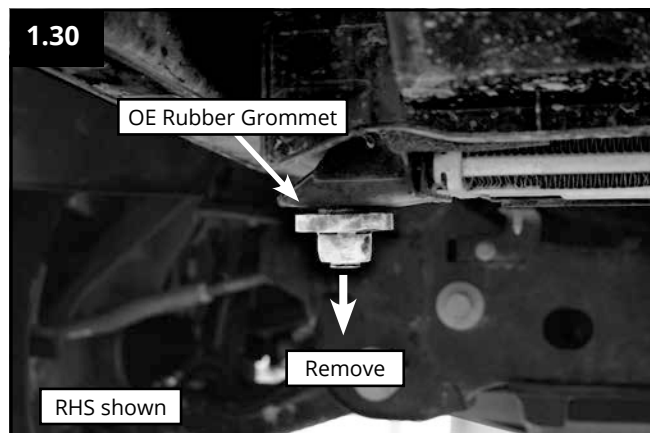

1.31 Replace the removed grommets with the grommets supplied with the bar kit.

Note: When pushing the intercooler up, ensure to align the top rubber grommet in its hole.

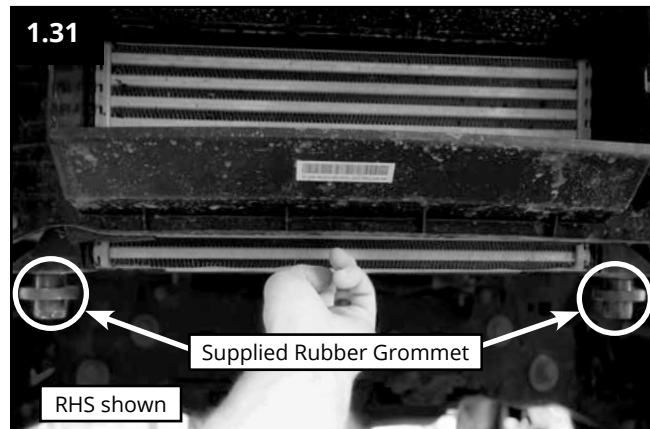

1.32 Remove lower bumper retainer bracket and hardware.

Repeat on right hand side.

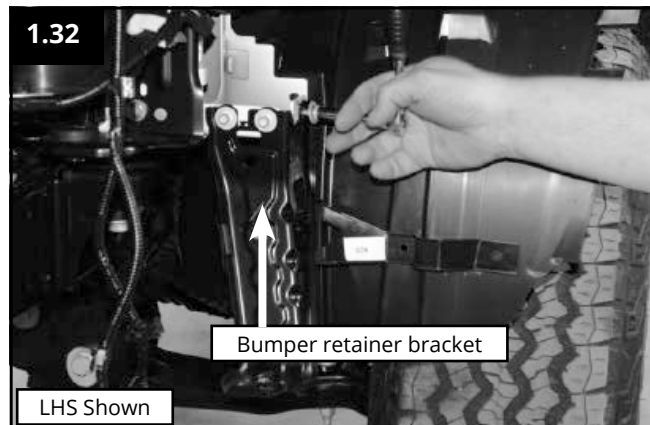

Step 2: Bracket Installation

Standard Kit (Non-Winch)

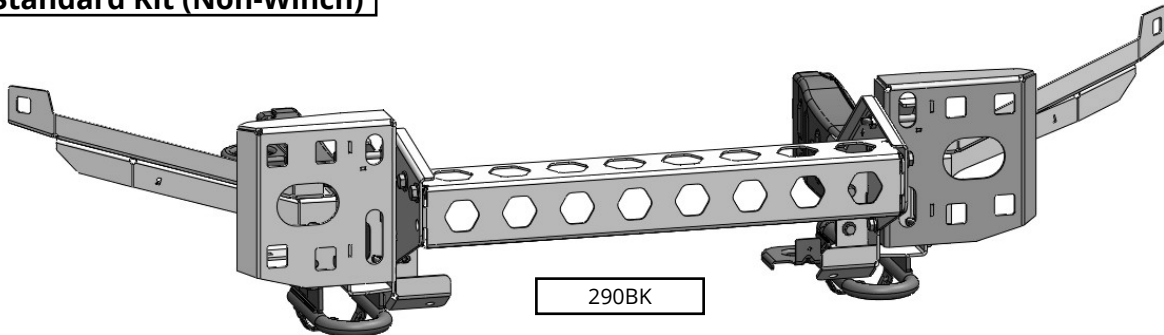

Winch Kit

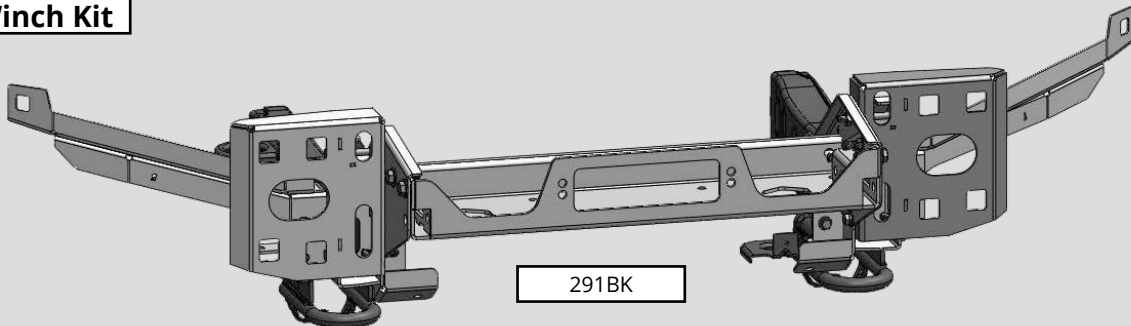

Standard Kit Only.

Leave all hardware loose until specified

2.1 Slide 290-CL over the chassis using the hardware shown. Only finger tighten.

Repeat on right hand side.

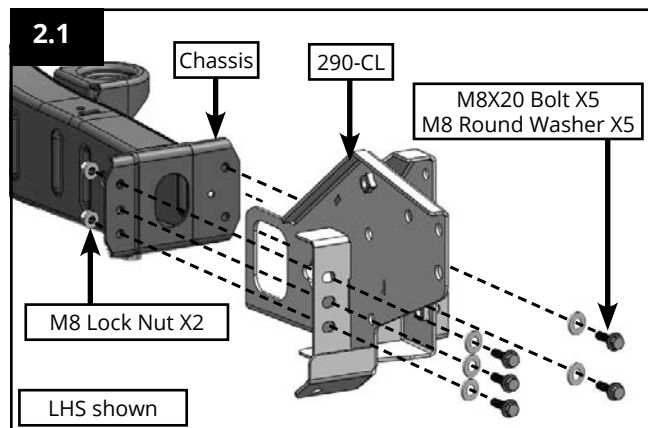

Winch Kit Only

2.2 Slide 290-CL over the chassis using the hardware shown. Only finger tighten.

Repeat on right hand side.

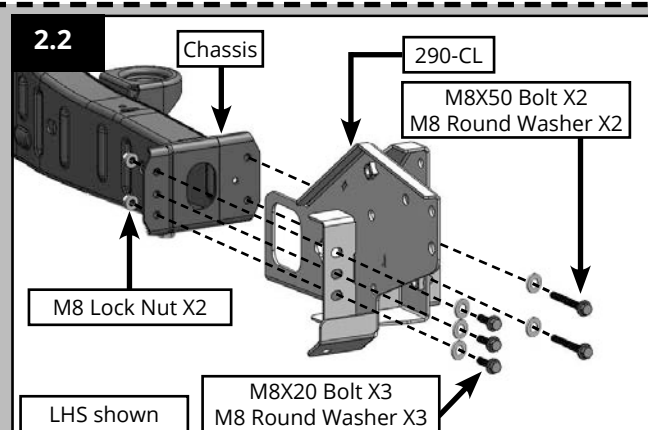

2.3 Install a cage nut to both 290-UM brackets provided.

Note: Cage nut must face upwards for installation.

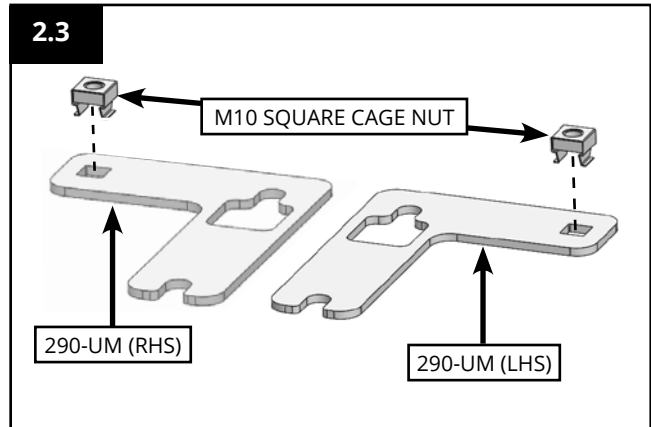

2.4 If not installing a recovery point, re-install the OE tow point under the 290-CL bracket as shown.

Repeat on right hand side.

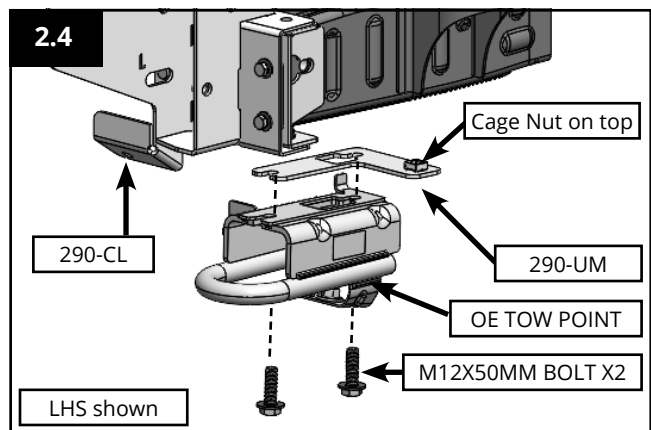

Recovery Point Install Only

2.5 If installing an ARB Recovery Point, install over the top of the 290-CL (Left) or 290-CR (Right)

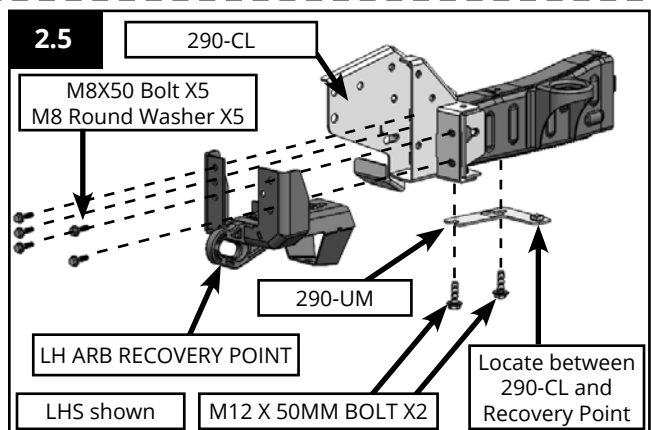

2.6 Fasten intercooler to OE tow points or ARB recovery points as shown.

NOTE: If not fitting to ARB recovery points, attach to OE tow points instead.

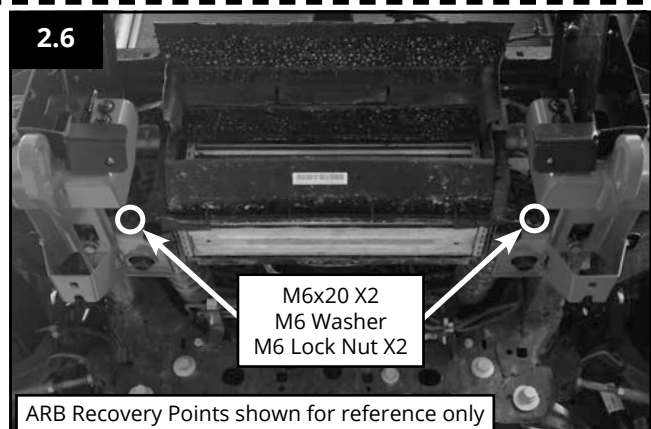

Winch Kit Only

2.7 Slide the 290-OL into place. Using hardware shown, secure the 290-OL bracket to the chassis.

Repeat on the other side.

Note: 290-OL and 290-OR are not mirrored parts, locate **L** and **R** on brackets for correct side.

2.7

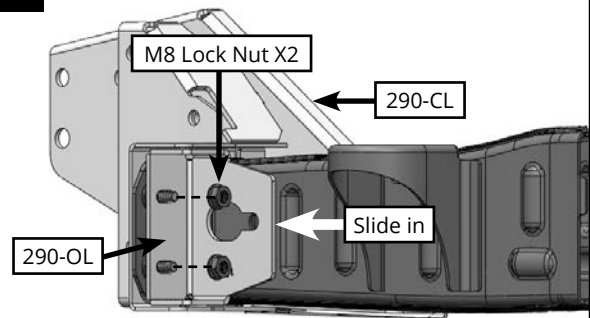

LHS rear chassis shown

2.8 Tighten all hardware from 2.1 to 2.7

Repeat on the other side.

 Ensure bracket is aligned to both front and base of the chassis, then tighten all fasteners as per torque specification.

NOTE: Recovery point shown for reference only.

2.8

Recovery point shown for reference only

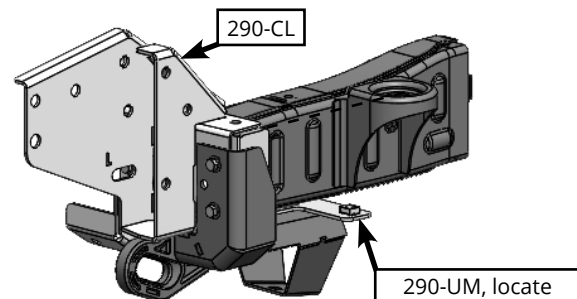

LHS shown

290-UM, locate between 290-CL and Recovery Point

2.9 Insert 290-CT (Crush tube) into chassis.

Winch Kit: fasten 290-LL to the 290-OL through chassis using the hardware shown.

Standard Kit: fasten 290-LL through to chassis directly using the hardware shown.

Leave hardware loose.

Repeat on right hand side.

2.9

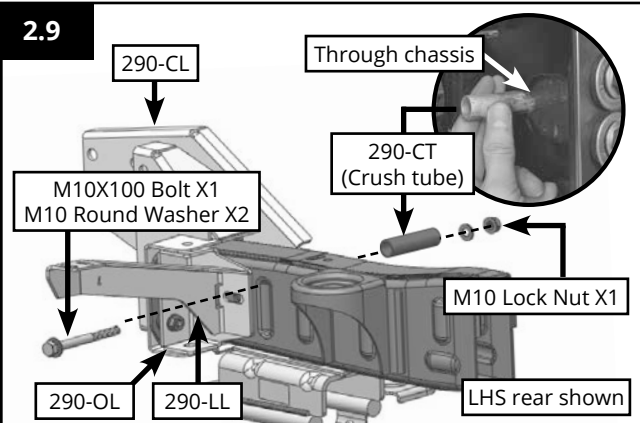

290-OL 290-LL

LHS rear shown

2.10 Install the 290-TL to the top of the 290-CL using the hardware shown.

Repeat on right hand side.

NOTE: 290-OR & 290-OL not required for **standard kit**

2.10

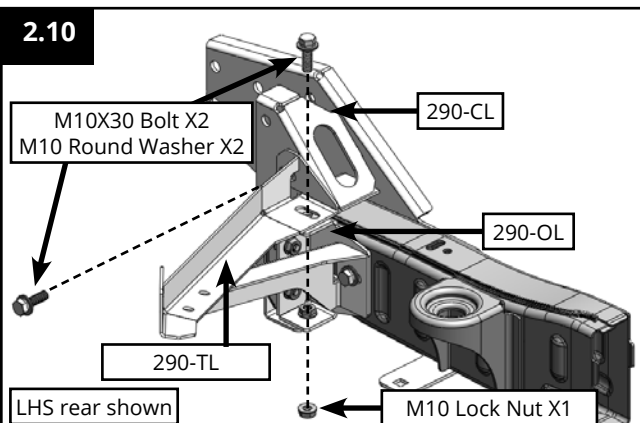

LHS rear shown

M10 Lock Nut X1

2.11 Using hardware shown, install the 290-TL to 290-LL.

Leave hardware loose.

Repeat on right hand side.

NOTE: Ensure bolt heads are facing down for tightening later.

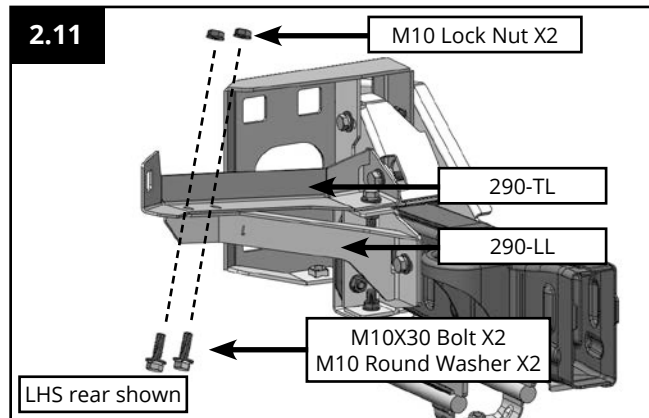

Standard Kit only.

2.12 Install 290-SB using hardware shown.

Repeat on the other side.

Tighten both sides to **44 Nm**.

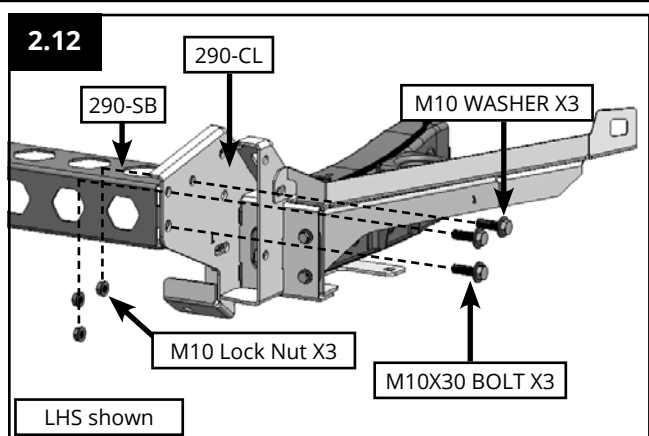

Winch Kit Only

2.13 Install hardware shown through 290-CL and 290-OL.

Repeat on the other side.

Tighten both sides to **44 Nm**.

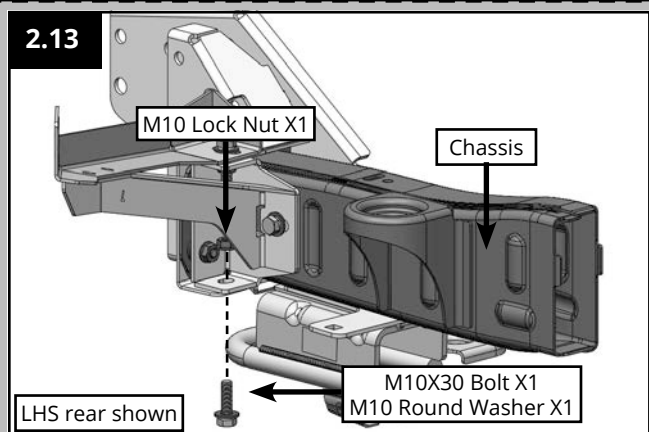

2.14 If the control box did not come attached to the winch, attach control box above the winch.

NOTE: If control box cannot be attached above winch, find an alternative location to install.



Winch Kit Only

2.15 Rotate winch handle to forward facing position of the vehicle.

NOTE: Other winches may have different gearbox rotation.

! Always consult the winch supplier instruction manual for correct handle rotation procedure.

2.16 If possible, rotate clutch handle to face outward from the vehicle as shown.

Note: Other winches may have different handle rotation.

! Always consult the winch supplier instruction manual for correct handle rotation procedure.

2.17 Install fairlead to 291-WB using the hardware supplied with the winch as shown.

Note: Check if winch wiring will reach the specified connection point before installing. Some winches may require wiring extensions, depending on control box location.

! Ensure the bolts do not hit the winch.
Maximum bolt protrusion: 15mm

2.18 Install winch to 291-WB bracket using the hardware supplied with the winch.

2.15

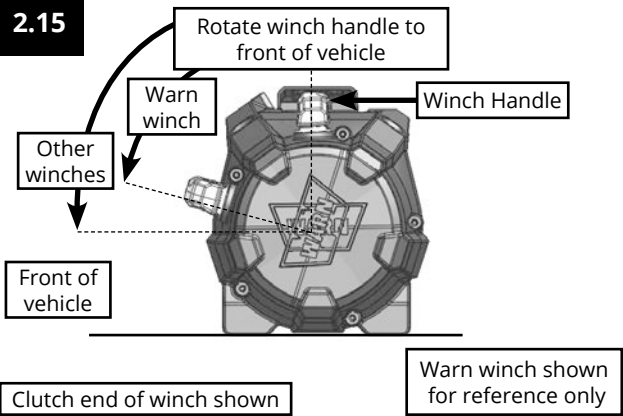

2.16

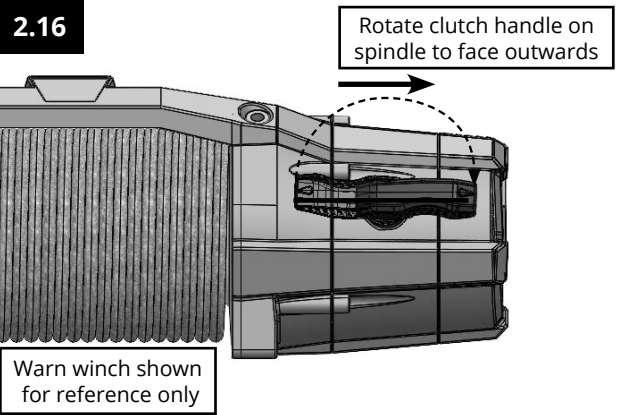

2.17

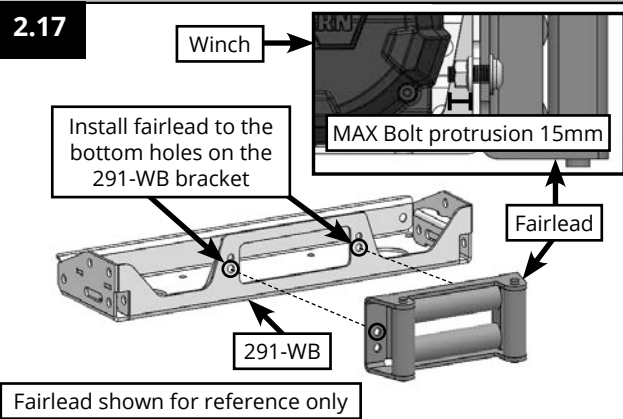

2.18

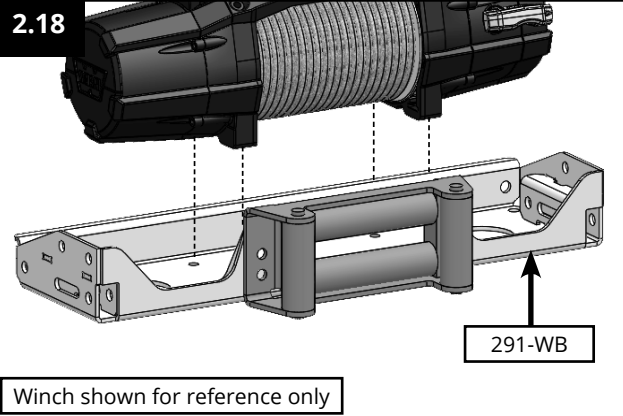

Winch Kit Only

2.19 Install 291-WB using hardware to the 290-CL as shown.

Repeat on right hand side.

Tighten Bolts to 78 Nm.

2.20 Wire winch to the vehicle per winch supplier's installation manual.

Note: The winch wires must be secured to the vehicle in maximum of 250mm spacing intervals.

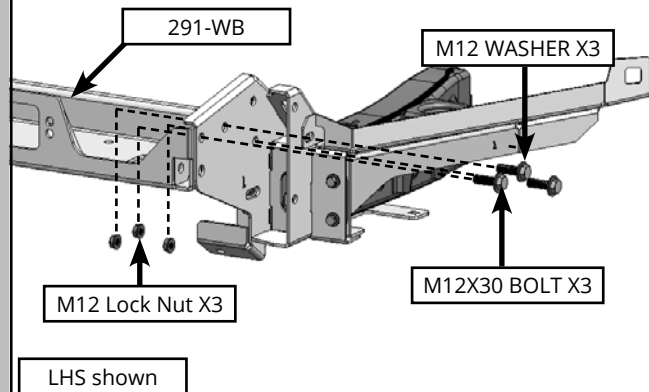
2.19

2.21 Install 290-BL to 290-CL using the hardware shown.

Leave hardware loose.

Repeat on right hand side.

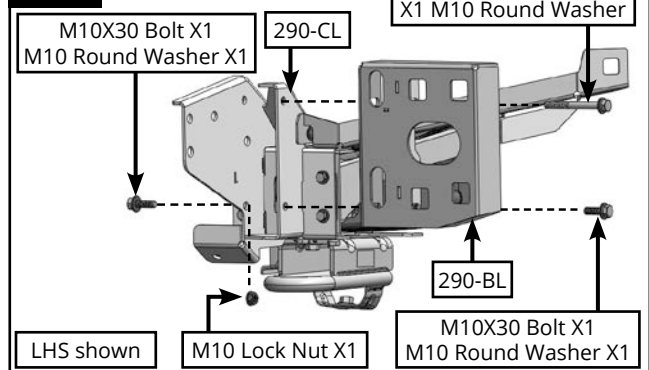
2.21

1.22 Cut the supplied double-sided tape by 20mm.

Clean both 290-RR and 290-RL with alcohol swap, and apply 3M primer and apply double-sided tape as shown.

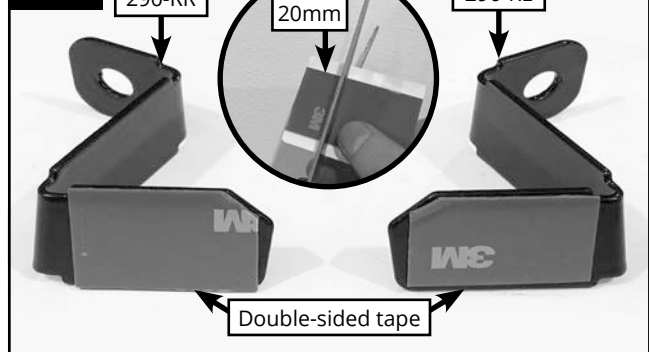
1.22

1.23 Install 290-RR onto the car behind the trimmed bumper using the OE Bolt as shown.

Clean inner surface of the bumper trim with alcohol swap and apply 3M primer.

Remove the tape film, press bumper trim firmly to the 290-RR bracket.

Repeat on the other side.

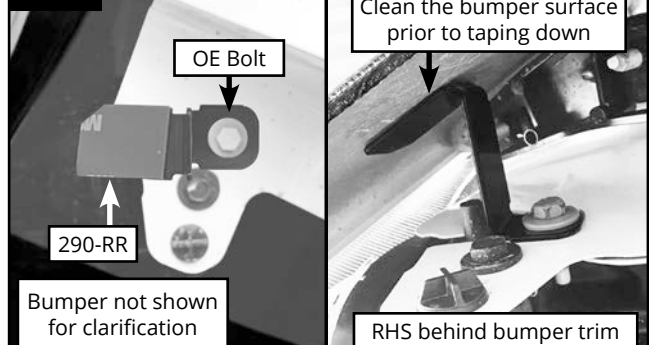
1.23

Step 3: Parking Sensor Installation

Non-Parking Sensor, skip to Step 4: Wiring

Parking Sensor vehicles only.

Note: Ensure that Parking Sensors have been labelled correct as per table in step 1.13

3.1 Rest harness on the back of the bar in the correct orientation as shown.

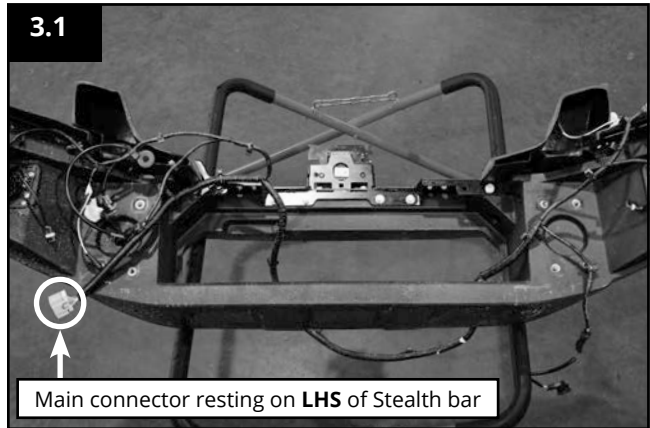

3.2 Connect the parking sensor extensions provided to the two **inner** parking sensor connectors.

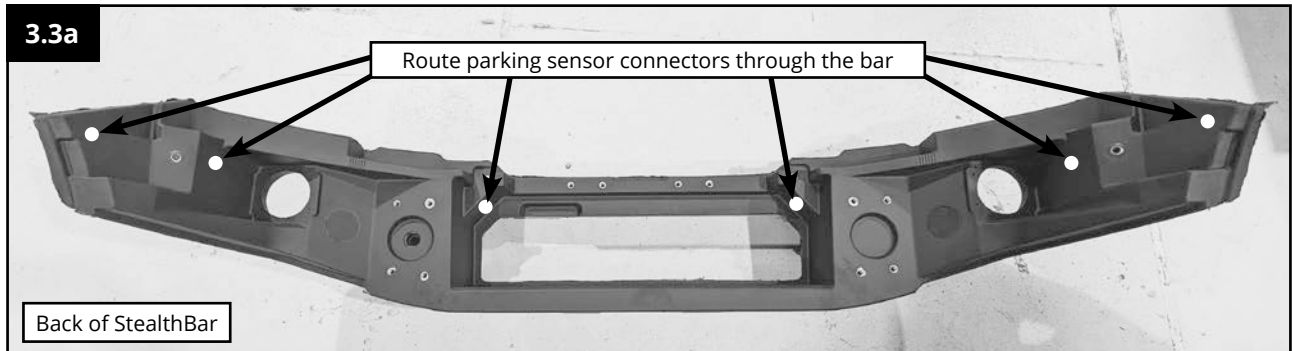
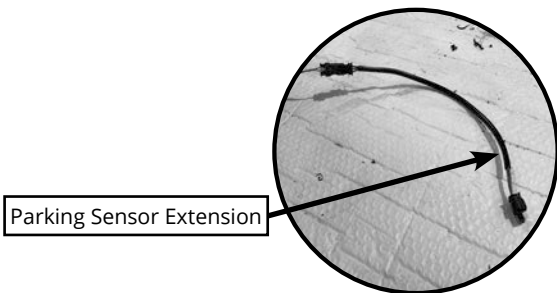
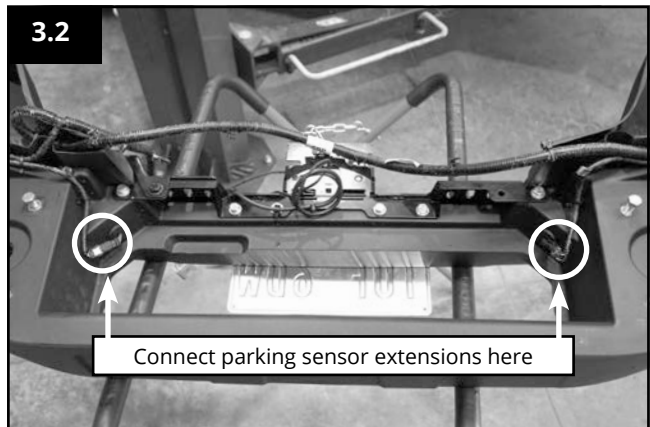

3.3 Route each connector through the back of the bar (shown on 3.3a) and out the front holes in the correct position.

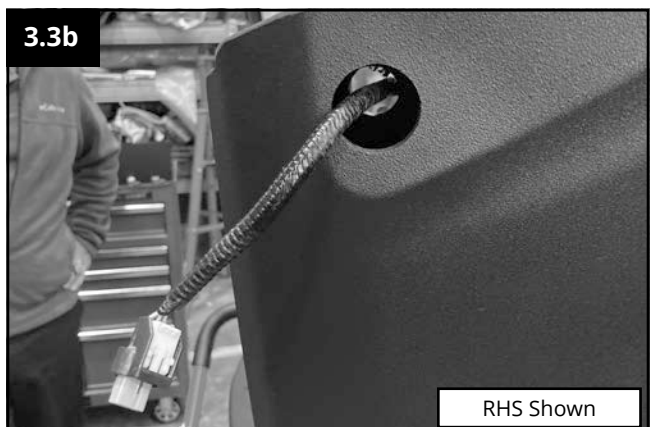

Parking Sensor Vehicles Only.

3.4 On the inner 2 parking sensors, ensure that the extension connectors are protruding through the rear of the bar, this will allow enough slack to fit the parking sensors.



3.5 Clip the parking sensors into the parking sensor bezels provided. Be sure to orientate the sensors as shown.

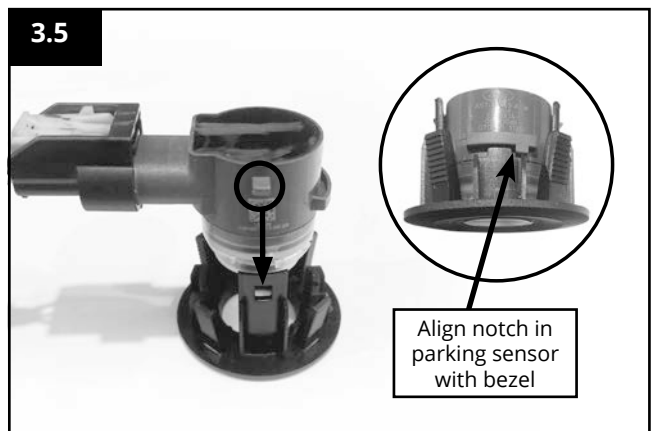

3.6 Check that parking sensors are positioned properly in the bezel and have not caught the seal.

Note: Make sure the bezel is facing the correct way. Locating dot on the same side as the bezel connector.

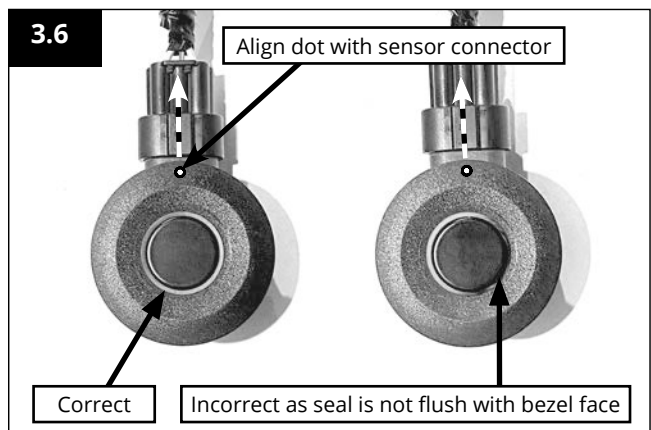

3.7 Re-connect the parking sensors to the wire connectors.

Ensure that all sensors are re-connected correctly as shown.

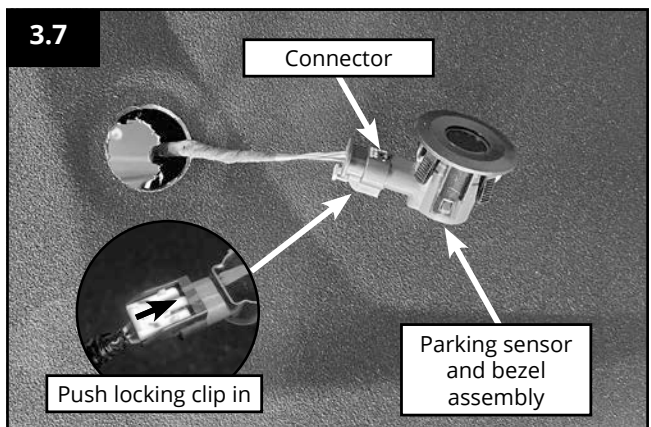

Parking Sensor Vehicles Only.

3.8a Clip the parking sensor and bezel into the bar. Ensure that sensors are orientated as shown.

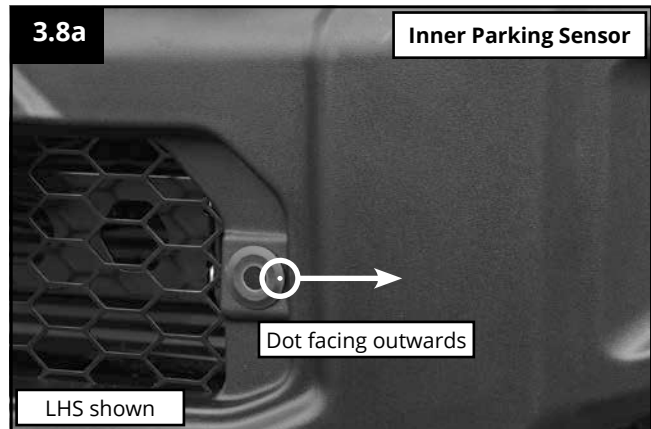

3.8b Left Middle parking sensor shown, repeat on right hand side.

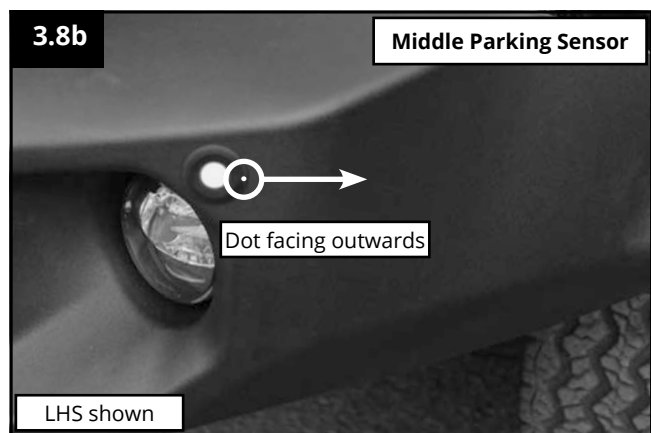

3.8c Left Outer parking sensor shown, repeat on the right hand side.

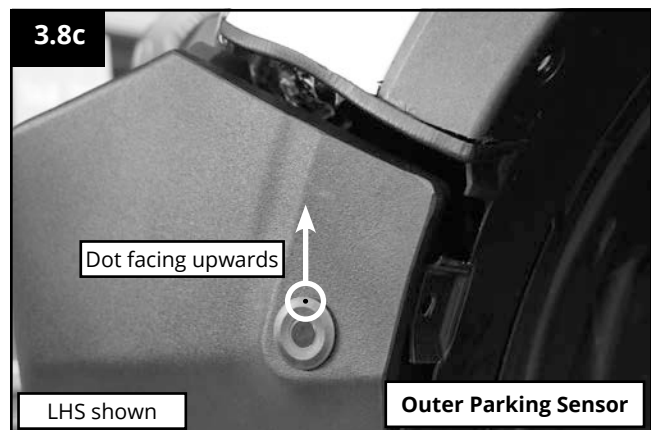

Note: Skip this step if vehicle only has **4 parking sensors**

Vehicles with 4 parking sensors only

3.9 Fit parking sensor hole plugs on the outer two holes, as shown.

Repeat on right hand side.

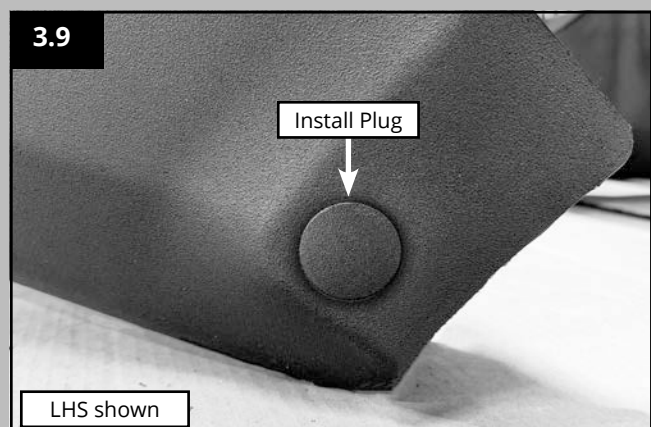

Parking Sensor Vehicles Only

3.10 Seal the parking sensor access holes by installing a split grommet on all holes as shown.

Repeat on right hand side.

3.11 Secure the parking sensor wiring harness to the bar by using the provided christmas tree clips.

Repeat on right hand side.

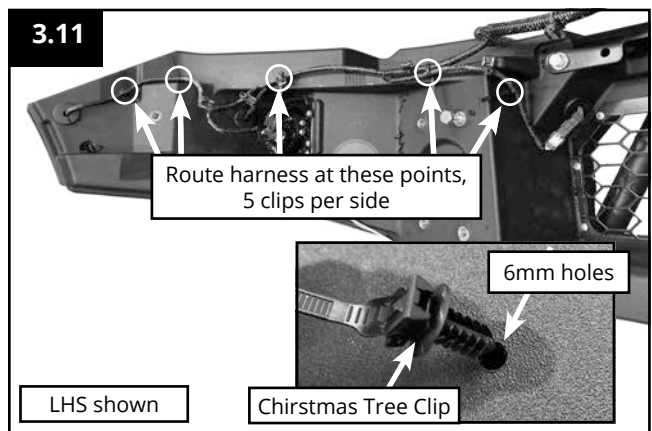
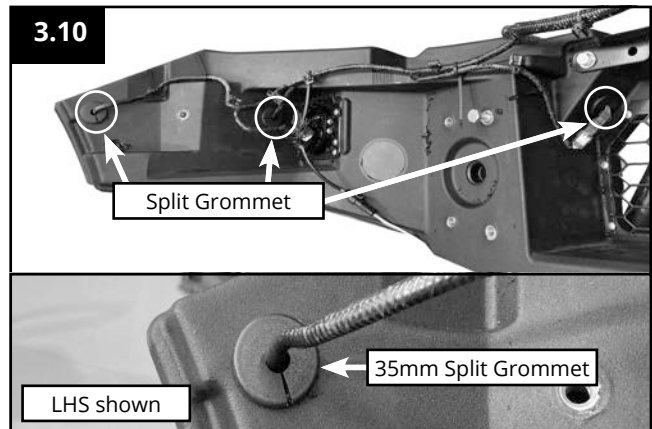

Step 4: Fog Light Wiring

Fog Light Vehicles Only.

4.1 Cut the **yellow wire** from the fog light connector installed in the bar.

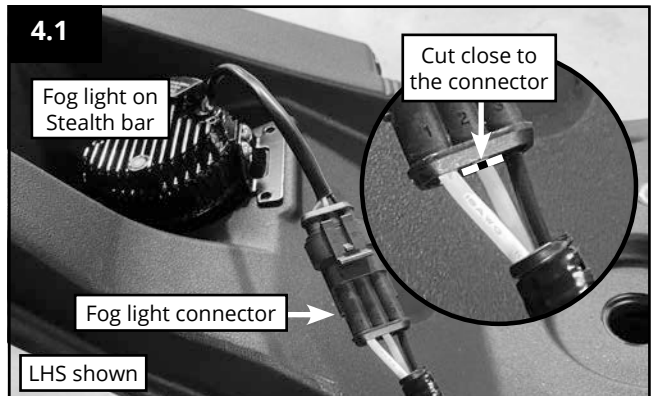

4.2 Cut OE fog connector wires off, exposing the fog light wires.

Discard the OE fog light and the connector.

Repeat on the other side.

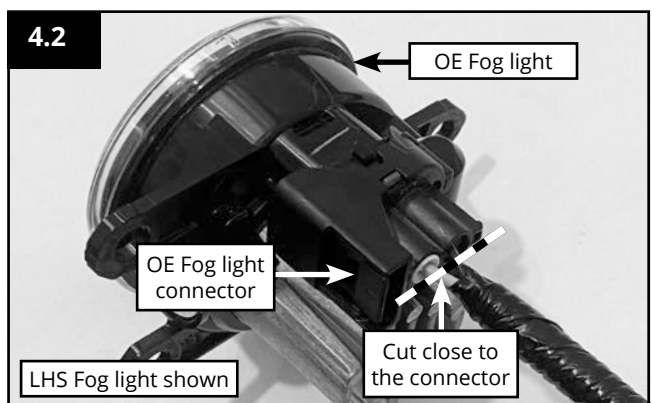

4.3 Wire the fog lights supplied in the bar approximately 100mm to the vehicle fog light loom.

Repeat on the other side.

Check 'vehicle fog light wiring table' for wire colours and functions to ensure the correct wires are connected.

Vehicle wiring colours may vary. Check to ensure wiring is correct.

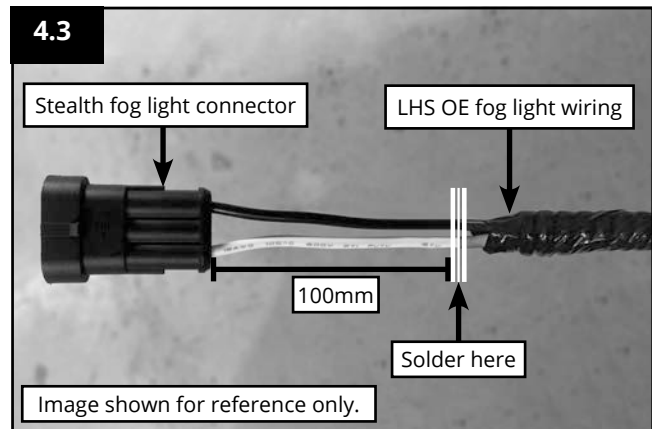

VEHICLE FOG LIGHT WIRING		
Function	Fog Light Wire	Vehicle Wire
Positive	White	LHS : Pink RHS : Yellow W/Red Stripe
Negative	Black	LHS: Black W/Green Stripe RHS : Black W/Grey Stripe

Step 5: Camera & Radar Housing

Front Camera Vehicles Only.

Note: Keep all removed camera components in a safe and secure place for re-installation.

5.1 Loosen the X3 Torx Screws to open camera housing.

Note: Place the grille face down on a soft surface to avoid damage.

5.2 Remove camera from housing in grille as shown.

Note: Keep camera in a safe place for re-installation.

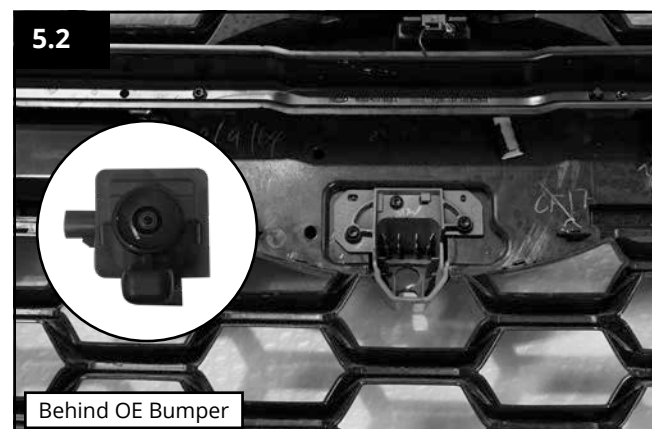
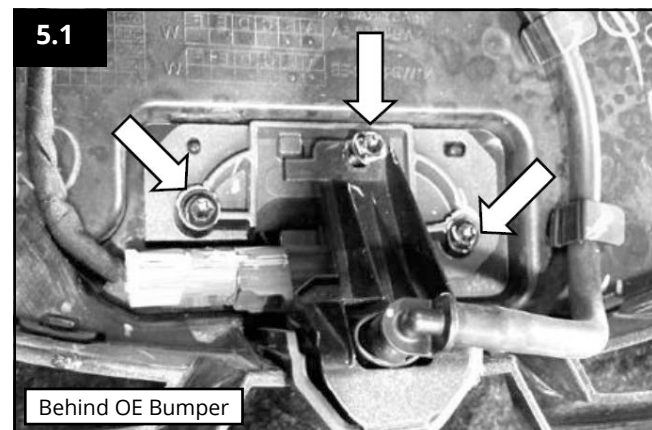

Front Camera Vehicles Only.

5.3 Disconnect washer hose from the camera.

Note: The hose needs to be off the vehicle.

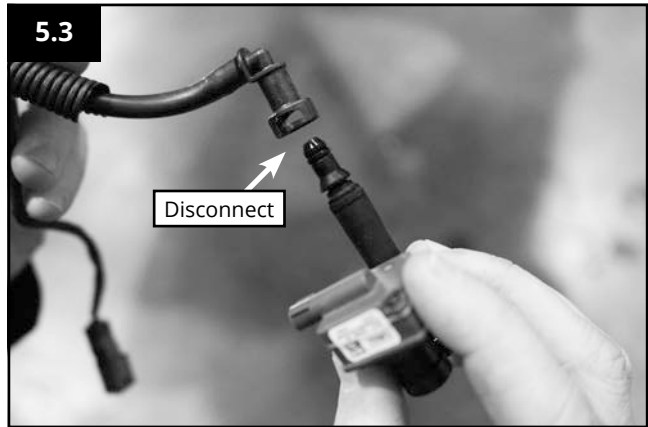

5.4 Disconnect the OE coax cable from the camera.

Note: The wiring needs to be off the vehicle. Set aside the camera for later steps.

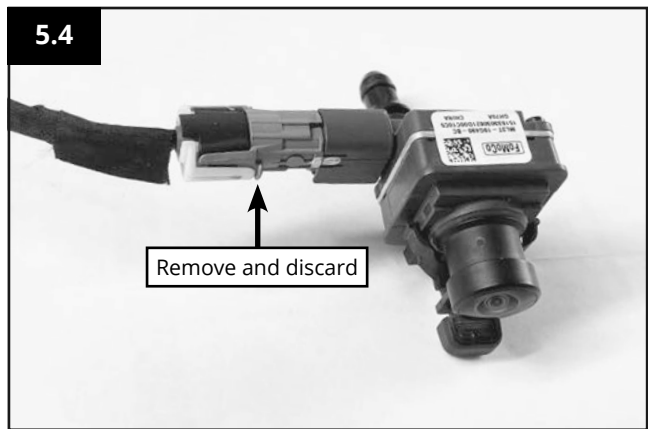

5.5 Remove the 90° elbow connector from the washer hose as shown.

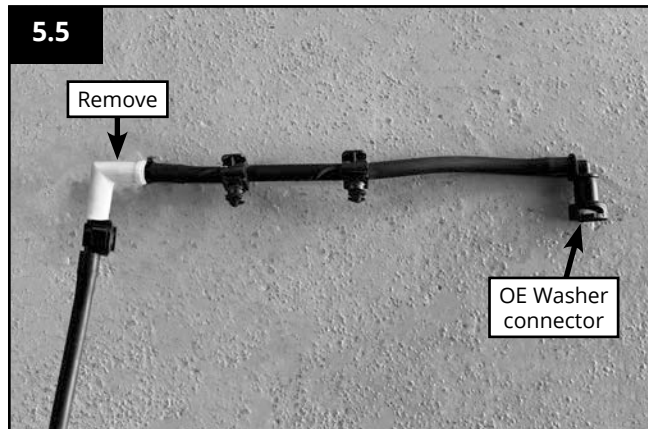

5.6 Replace the 90° elbow connector with hose extension as shown.

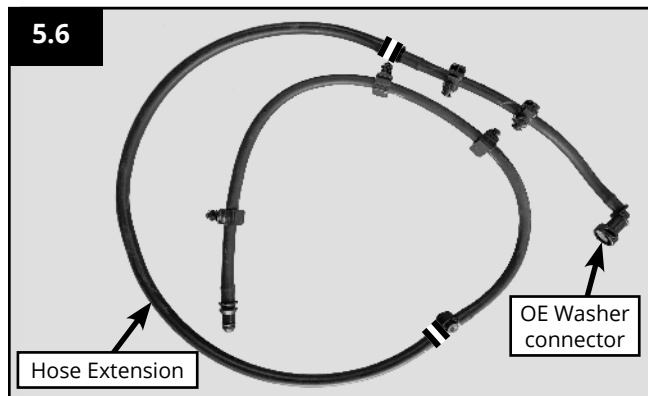

Front Camera Vehicles Only.

5.7 Apply Split tube to group hose and cable as shown.

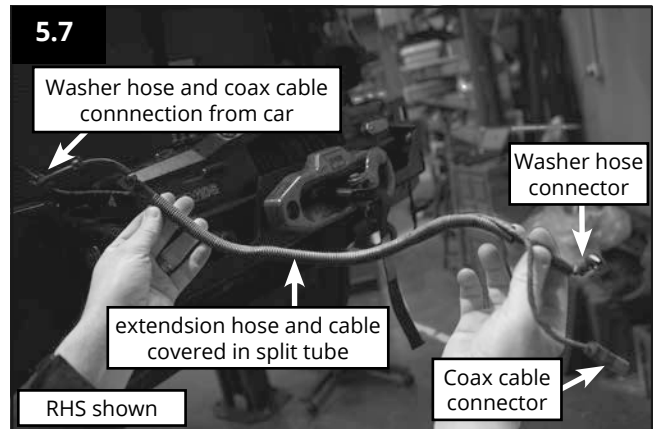

5.8 Install the front camera using the brackets and hardware shown.

Note: The wiring & hose needs to be off the vehicle. Set aside both ends of hose and camera for later steps.

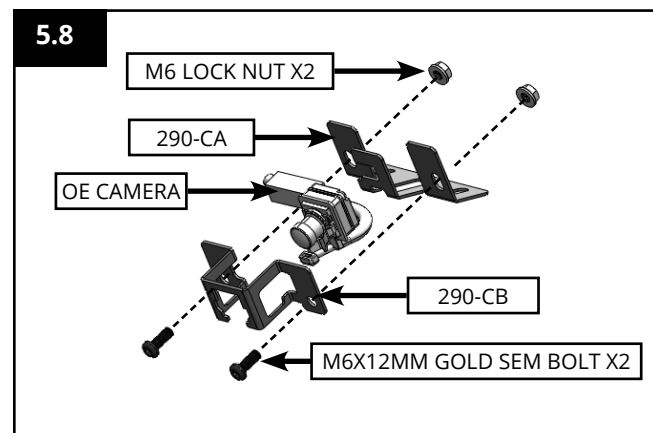

5.9 Install M6 cage nuts to the radar bracket as shown.

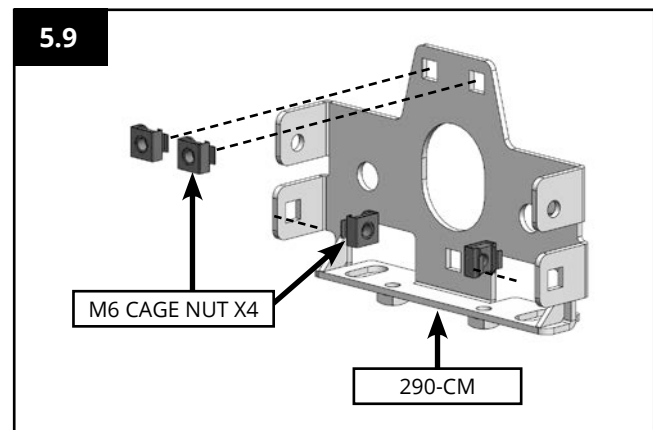

5.10 Install 290-CA to the 290-CM bracket using the hardware shown.

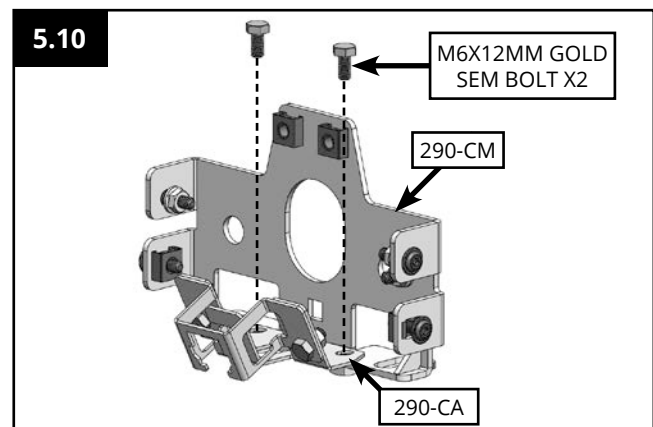

Front Camera Vehicles Only.

5.11 Route extended washer hose and cable through the access hole in the 290-CM bracket as shown.

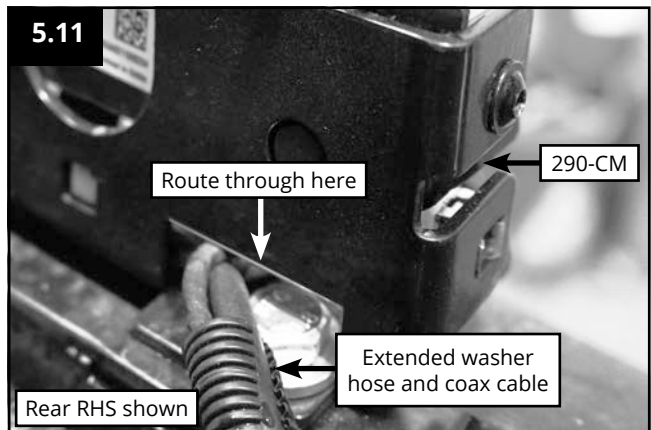

5.12 Connect Coax cable and washer hose to camera.



5.13 Connect Coax cable to camera.

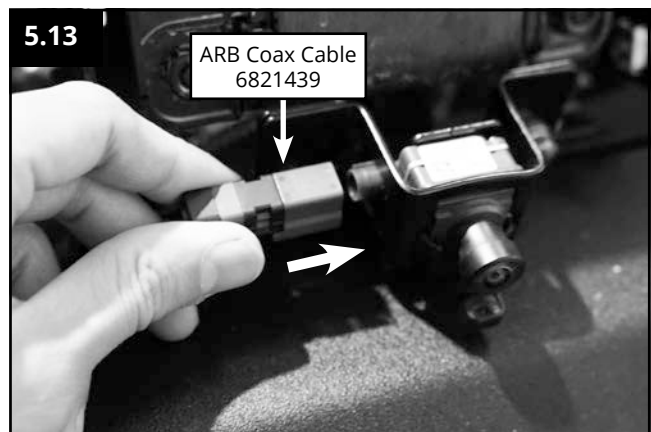

5.14 Reattach radar to the trimmed OE bracket.

Install the OE bracket to the 290-CM bracket using the hardware shown.

Note: Camera shown for reference. Only for vehicles equipped with a camera.

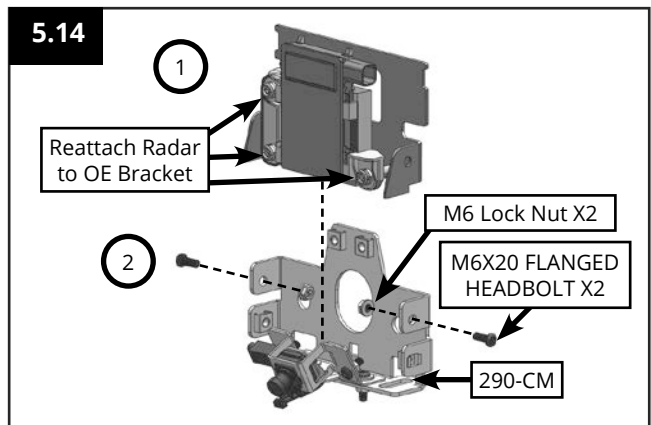

5.15 Install bracket hardware as shown.

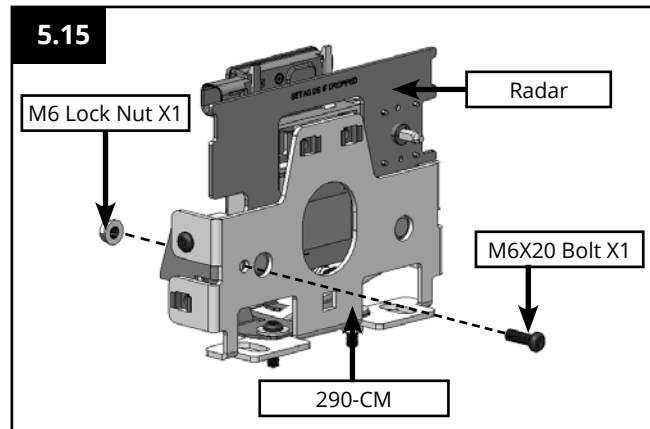

5.16 Install radar assembly to the 290-AB bracket using the hardware shown.

Ring spanner recommended.

Note: Camera shown is only present in vehicles equipped with a camera. Leave loose at this stage.

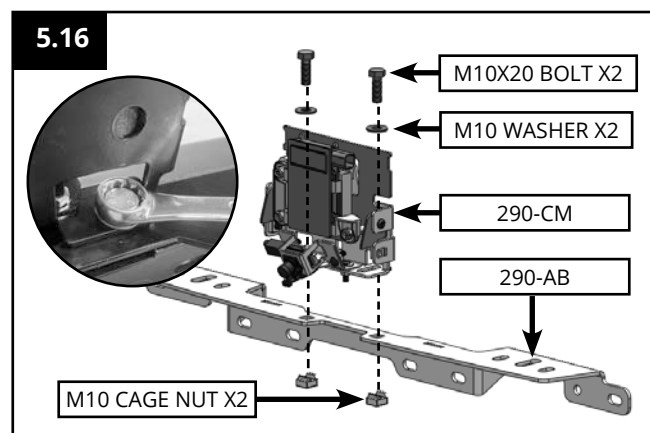

Step 6: StealthBar Component Installation

Important: Before Proceeding

- Use anti-sieze on all hardware mounted to the StealthBar
- A maximum torque of 28Nm is required for M10 Bolts and 55Nm for M12 bolts being tightened into the stealthbar **THESE MUST NOT BE OVER TIGHTENED.**

If fitting any accessories to the 290-AB bracket, install before mounting the bracket to the bar.

When installing aerial mount without spotlights.

6.1a If required, install the 290-AML bracket to the 291-AB bracket prior to fitting to the bar.

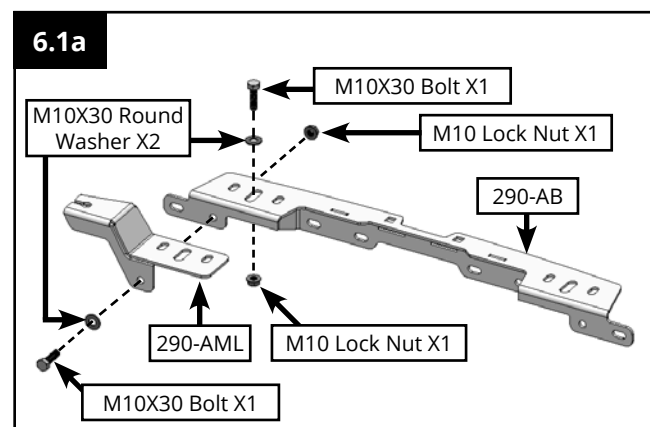

When installing spotlights without aerial mount. (290-AML not required)

6.1b If required, Install spotlights to the 290-AB using the light hardware as shown.

NOTE: Light bars cannot be mounted to the 290-AB bracket

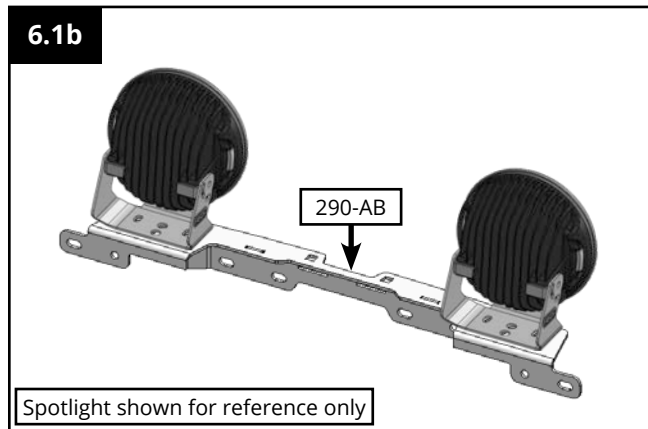

When installing an Aerial Mount with spotlights

6.1c Install 290-AML to the 290-AB as shown in step 6.1a.

Place 190-ABS in between the 290-AB and the Spotlight on the opposing side, to ensure that the lights sit level.

Install spotlights with hardware supplied with lights.

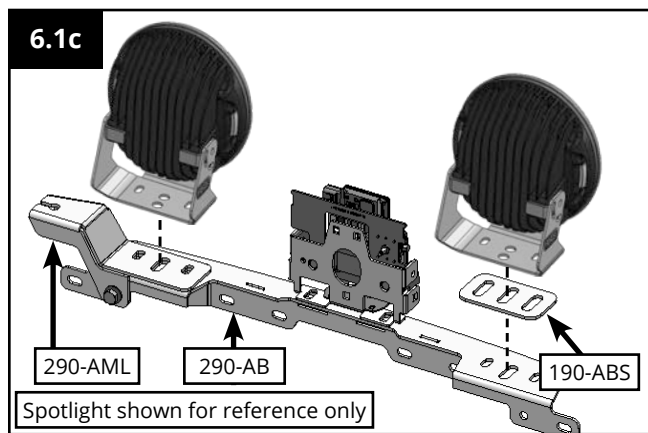

6.2 Use Anti Sieze on all bolts, and install the 291-AB using the hardware shown.

NOTE: Ensure that the radar and any Spotlights are installed to the 290-AB prior to installing to the bar.

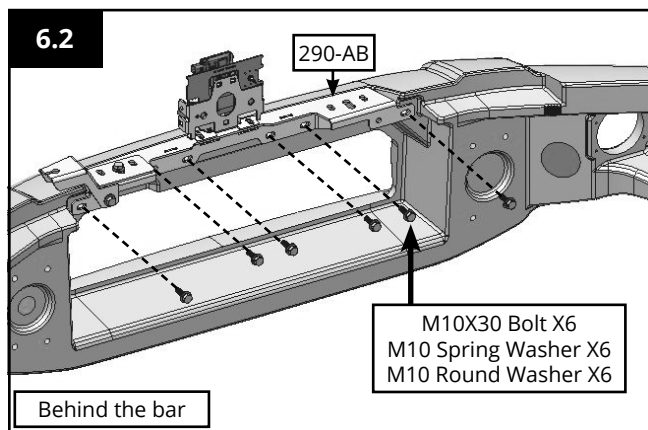

Winch Kit Only

6.3 If installing a winch now, remove the Mesh (290-MC) from the bar as shown.

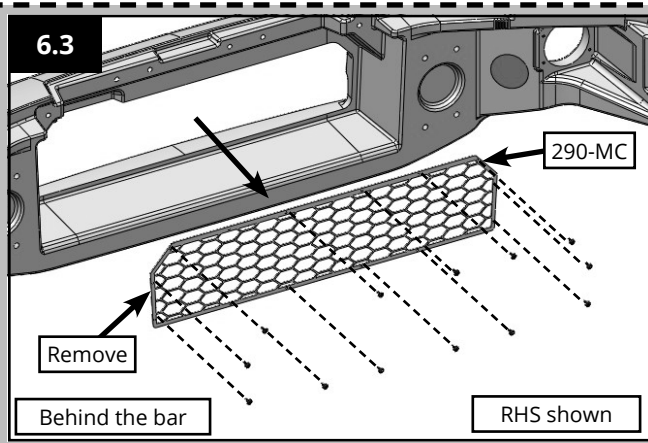

Standard Kit Only

6.4 Install Grille Cover to the bar using the hardware shown.

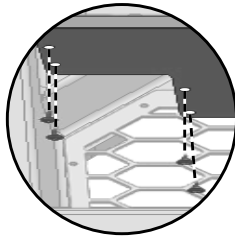

NOTE: Ensure the bend of 290-GC is facing down.

6.5 Install 290-GL using hardware shown.
Repeat on right hand side.

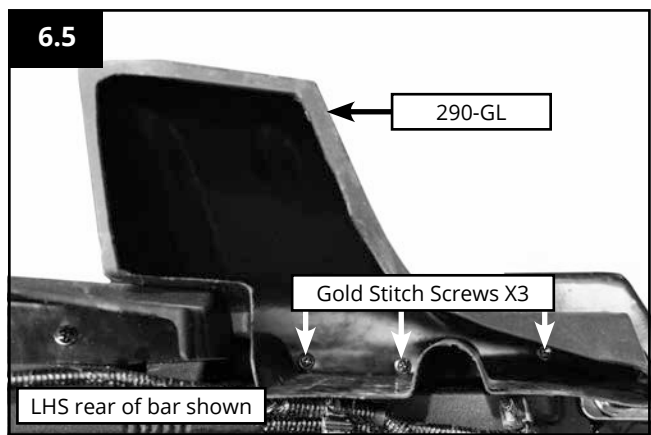
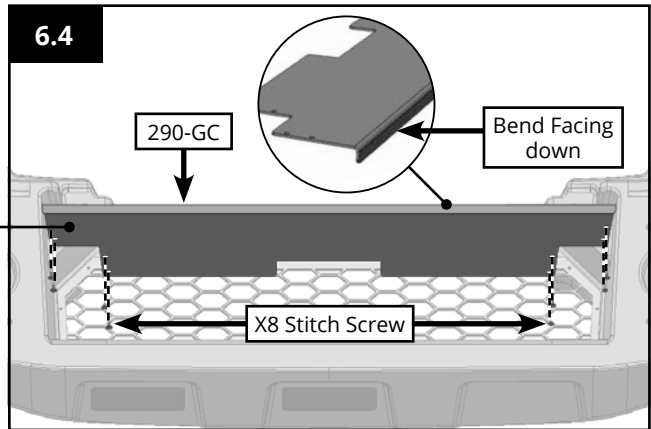

6.6 Install 290-HL using hardware shown.
Repeat on right hand side.

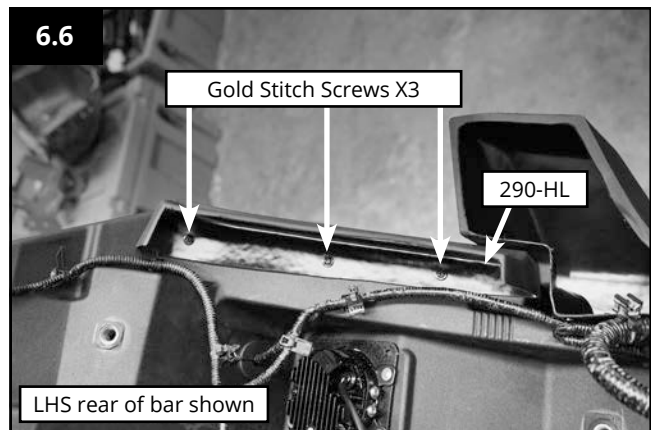

6.7 Ensure that the 290-GR/290-GL are aligned centrally to the bar and check the reference dimension as shown.

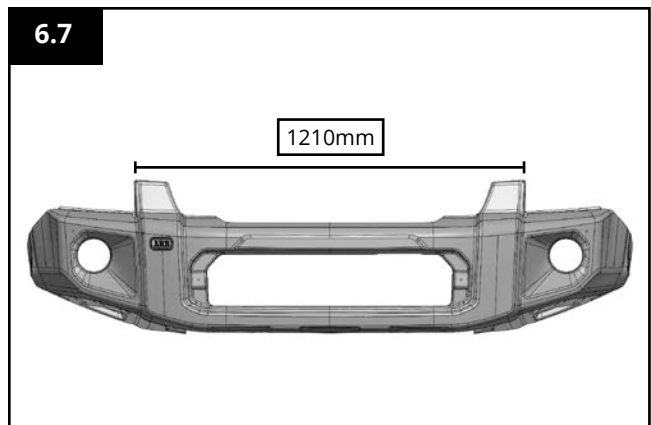

Winch Kit Only**FORD RANGER, XL, XLS MY22 GRILLE ONLY**

6.8 If installing a winch with a control box mounted to the winch. Mark and cut the grille as required to allow re-fitment of the grille to the vehicle.

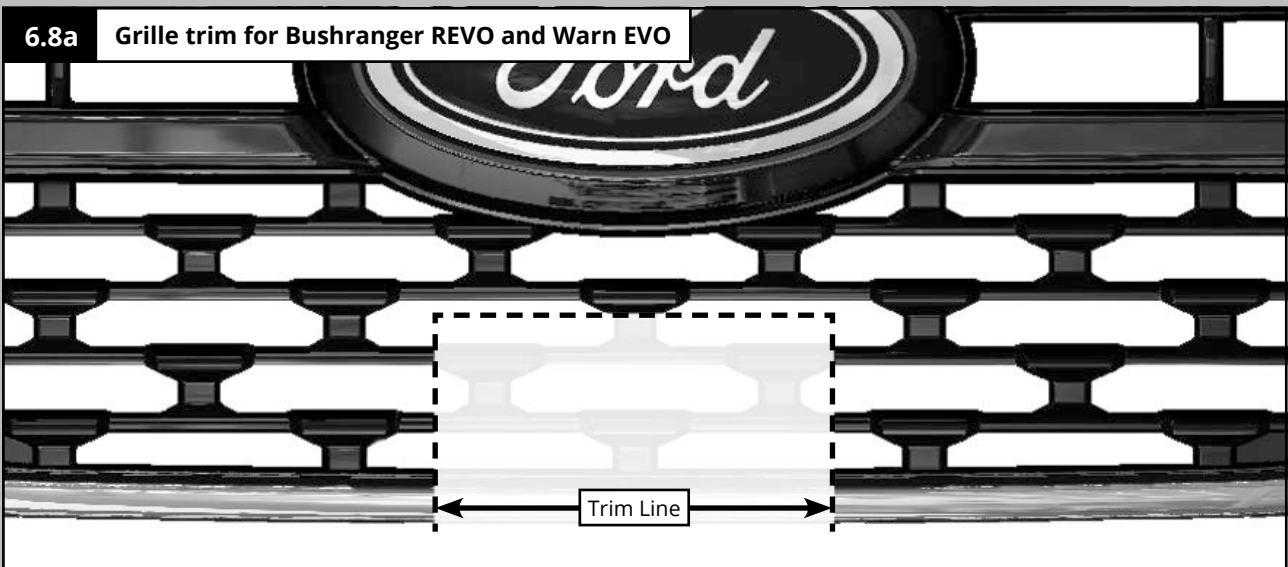
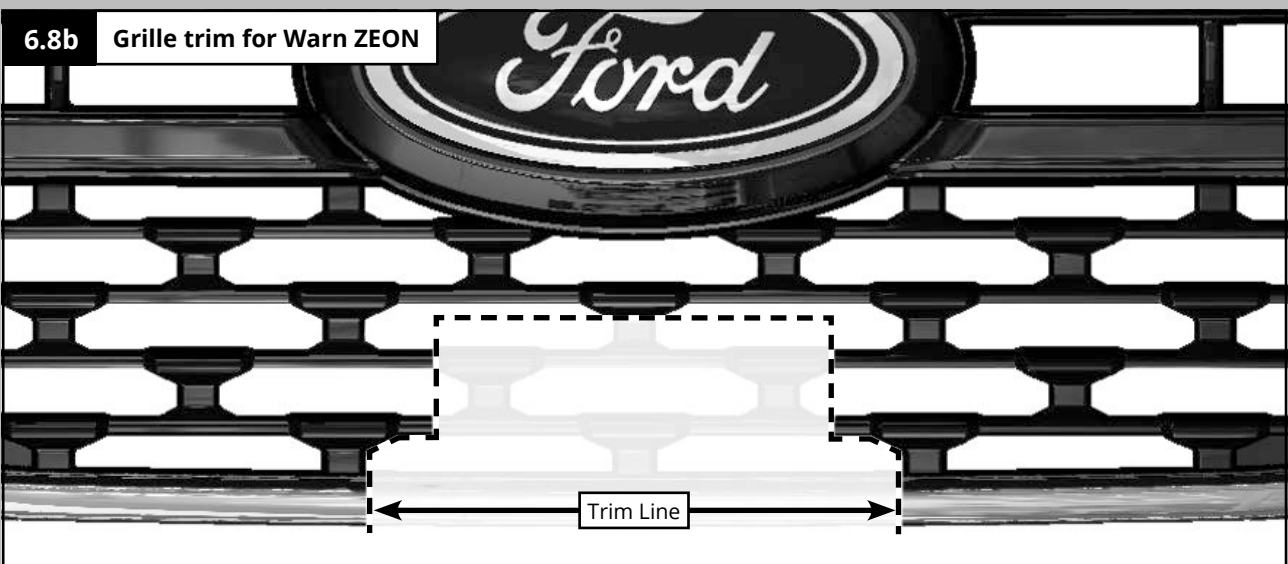
6.8a Grille trim for Bushranger REVO and Warn EVO**6.8b** Grille trim for Warn ZEON

Winch Kit Only

FORD RANGER XLT, SPORT MY22 GRILLE ONLY

6.9 If installing a winch with a control box mounted to the winch. Mark and cut the grille as required to allow re-fitment of the grille to the vehicle.

6.9a Grille trim for Bushranger REVO and Warn EVO

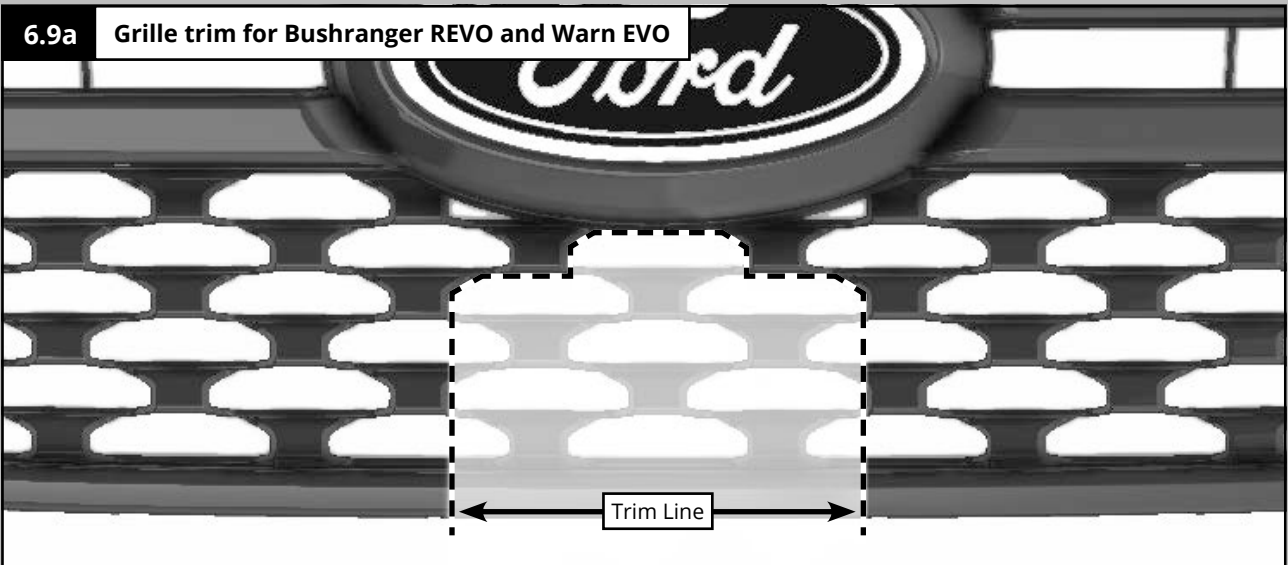

6.9b Grille trim for Bushranger REVO and Warn EVO

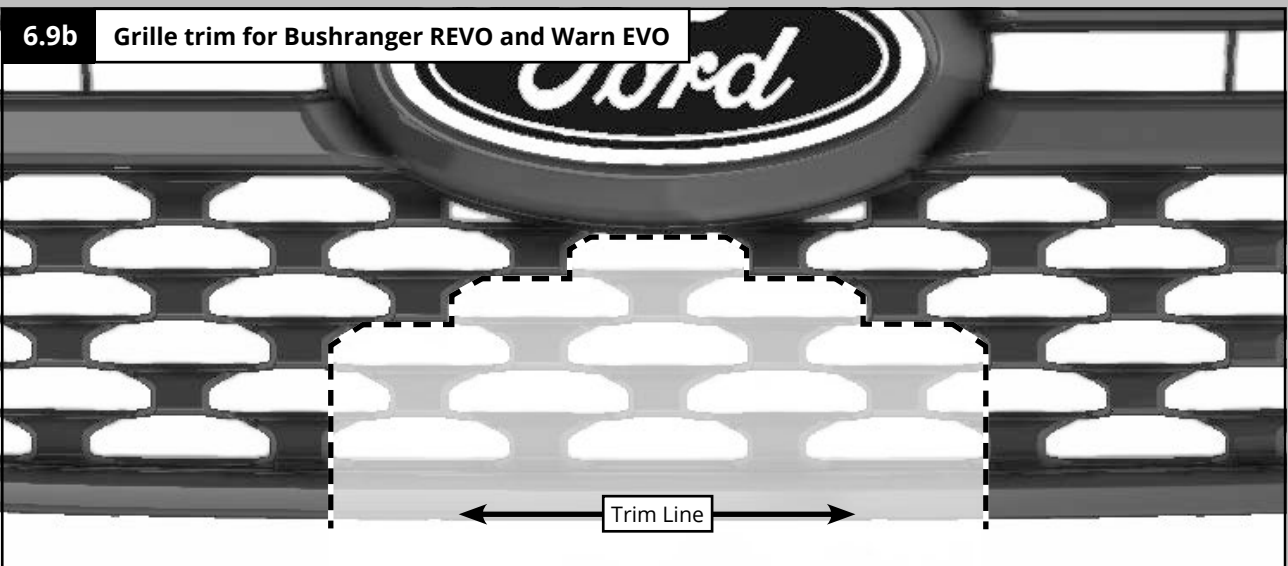

Winch Kit Only

FORD RANGER WILDTRACK MY22 GRILLE ONLY

6.10 If installing a winch with a control box mounted to the winch. Mark and cut the grille as required to allow re-fitment of the grille to the vehicle.

6.10a Grille trim for Bushranger REVO and Warn EVO

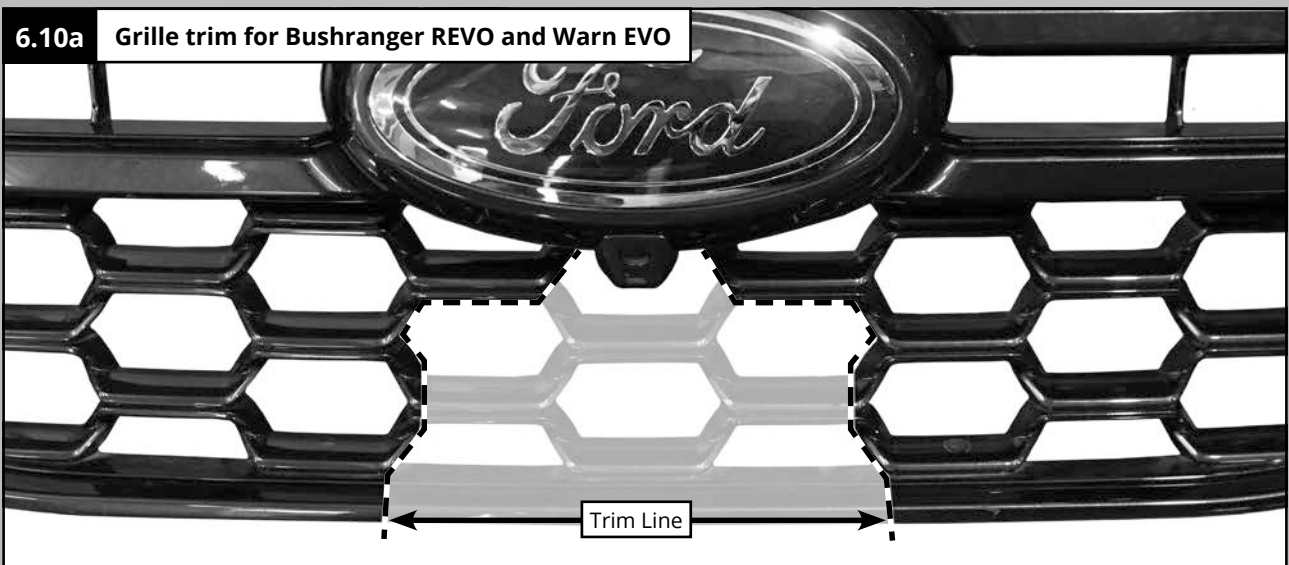

6.10b Grille trim for Warn ZEON

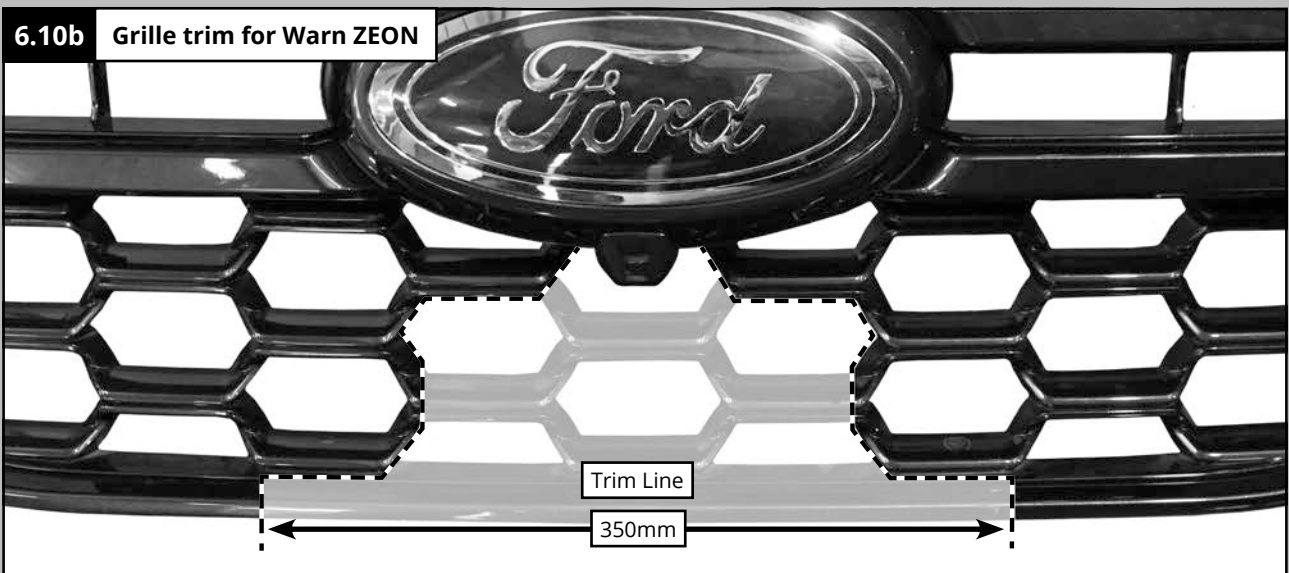

Winch Kit Only

FORD RANGER XL, XLT, EVEREST PLATINUM MY22 GRILLE ONLY

6.11 If installing a winch with a control box mounted to the winch. Mark and cut the grille as required to allow re-fitment of the grille to the vehicle.

6.11a Grille trim for Bushranger REVO and Warn EVO

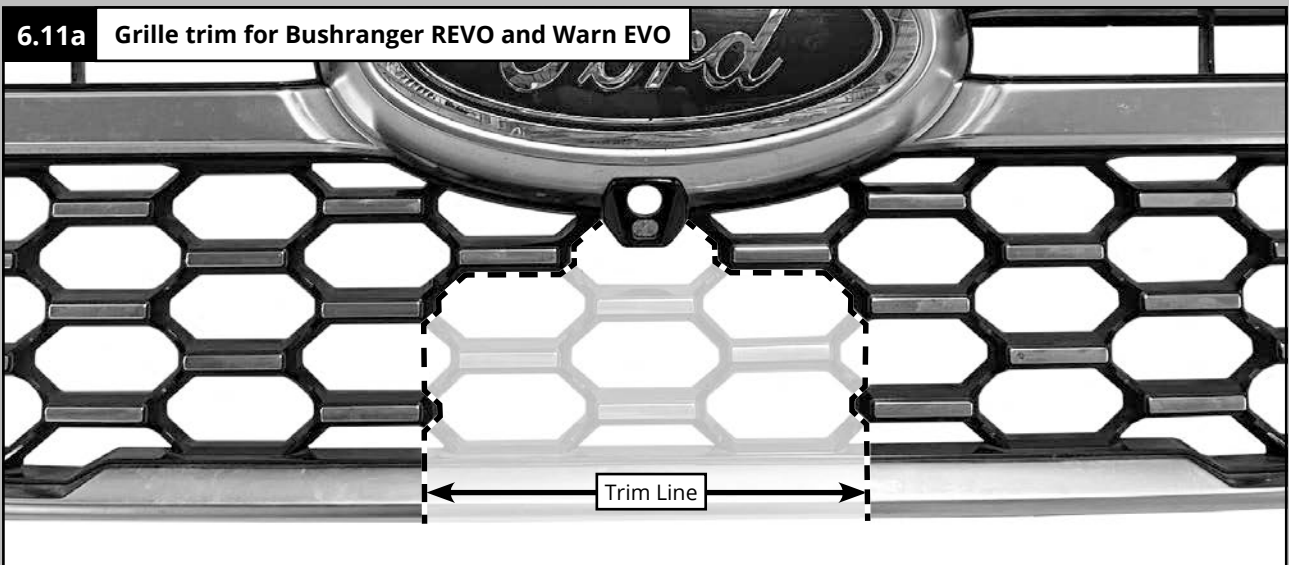

6.11b Grille trim for Warn ZEON

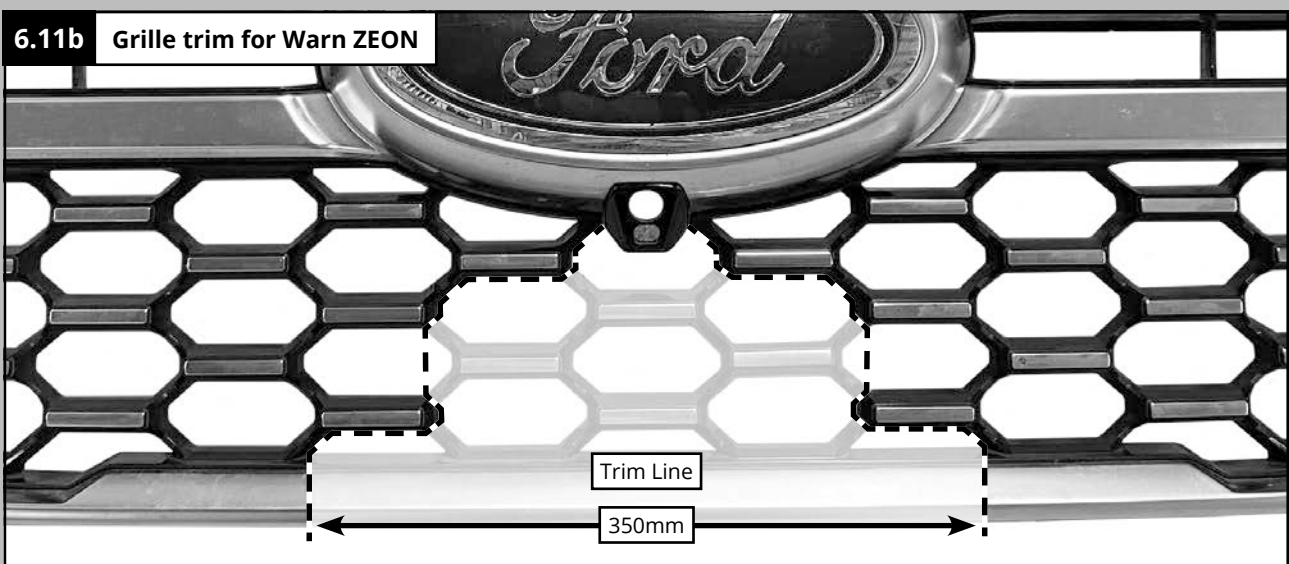

**FORD EVEREST AMBIENTE, TREND, SPORT.
FORD RANGER WILDTRACK ONLY.**

6.12b Mount the cage nuts to the underside of 290-GB.

NOTE: Ensure the bend on 290-GB is facing downward.

6.12b

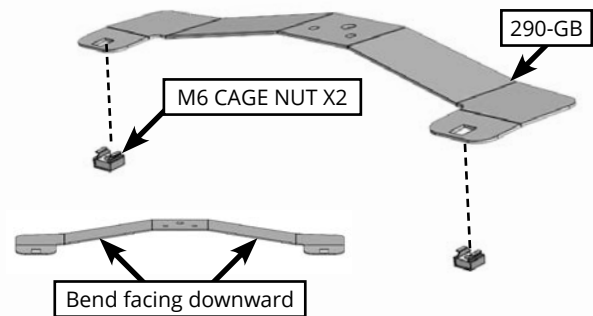

6.13 Install the 290-GB to the centre grille mount using the hardware shown.

NOTE: 290-GB shown for reference only.

6.13

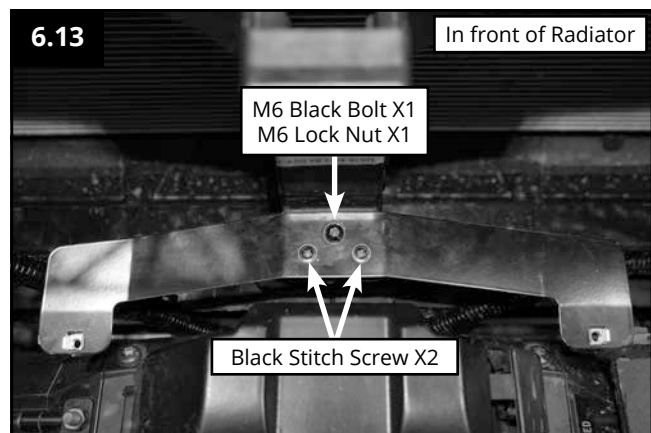
Fog Light Kit (SA290FLK) install only.

6.14 If installing aftermarket fog lights, remove the 141-LI (Light infills) from the bar and install fog lights as per separate kit fitting instructions.

Note: SA292 Stealth Bar comes with fog lights already installed.

6.14

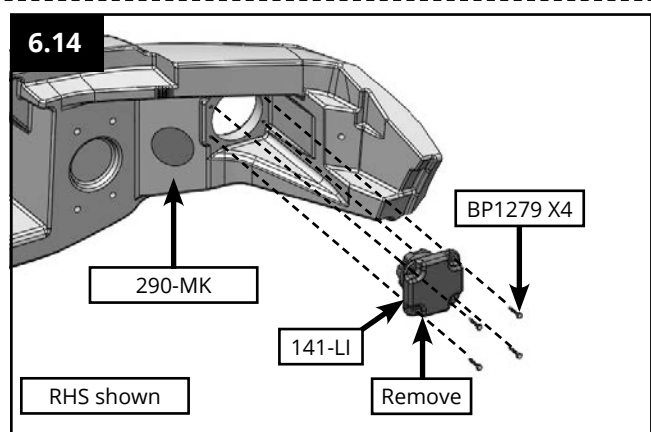

Step 7 : StealthBar Install

Important: Before installing the bar

- Use Anti Sieze on all bolts in the following steps.
- A maximum torque specification of 28Nm is required for M10 Bolts and 55Nm for M12 bolts being installed into the StealthBar. **THESE MUST NOT BE OVER TIGHTENED.**

7.1 Install X2 Bolts to temporarily hang the bar to the brackets for installation.

Winch and Spotlight Installs Only

If installing a winch, fog lights or spotlights, it is recommended to connect the wiring to the vehicle now.

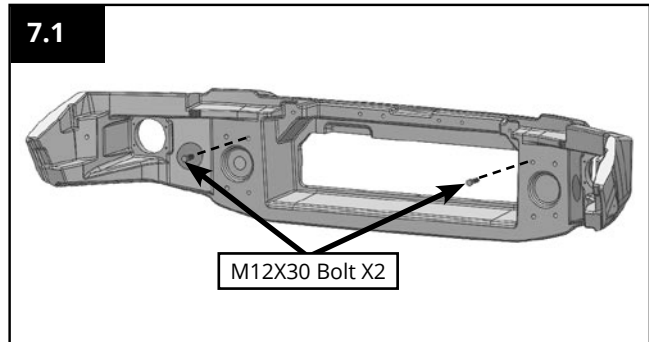

7.2 Install the bar to the vehicle using the hardware shown.

Leave hardware loose.

Repeat on the left hand side.

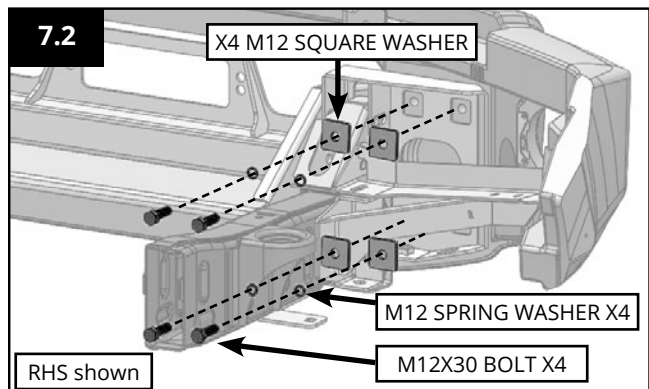

7.3 Secure the wing bracket to the bar using the hardware shown.

Leave hardware loose.

Repeat on the left hand side.

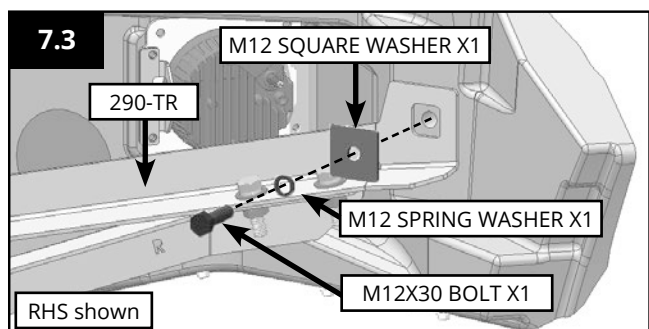

7.4 Align the StealthBar so that it is central left to right to the vehicle.



7.5 Align the StealthBar so that it follows the wheel arch line and has 20mm gap between the bar and bumper.

Check on both sides of the vehicle.

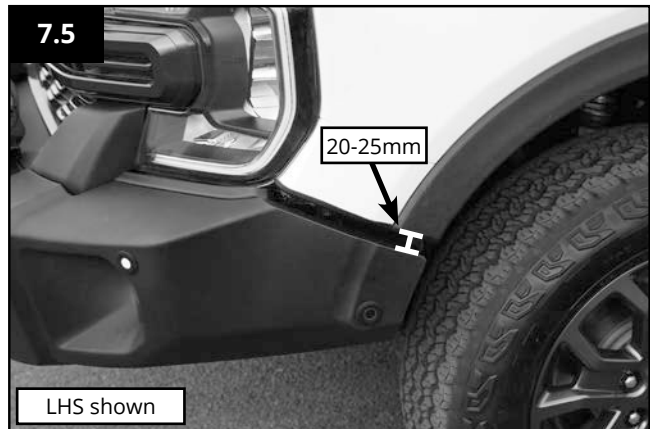

7.6 Ensure that the headlight and grille infill are aligned with the vehicle with an even gap on both sides of the vehicle.



7.7 Once bar is aligned, tighten StealthBar and bracket hardware to specified torque as shown.

M12 Fasteners: **Max 55Nm.**

⚠ Do not overtighten bolts.

Repeat on the other side.

Once complete, tighten all bracket hardware to hold in place.

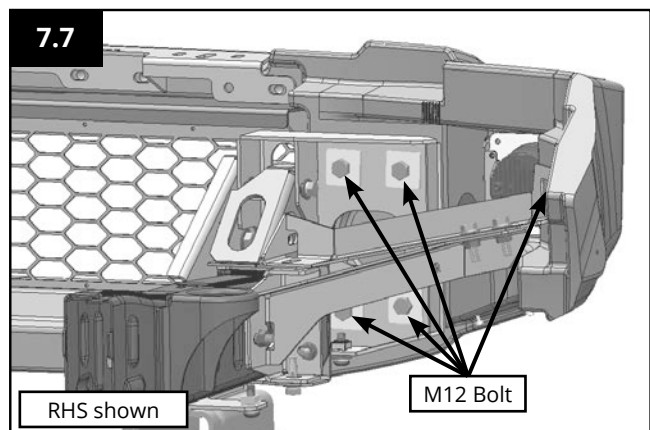

7.8 Adjust the camera bracket forward/back until the bar can be seen slightly as shown.

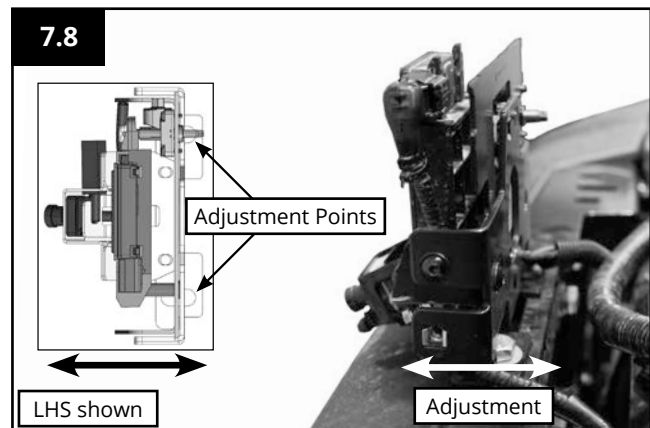
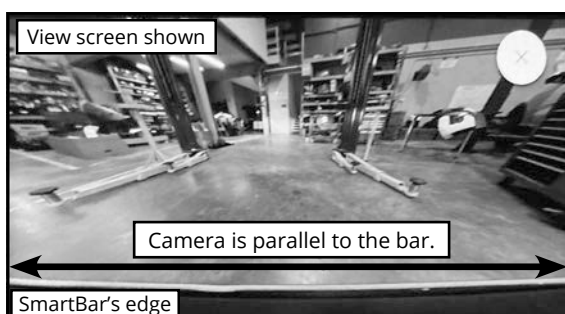

7.9 Reconnect the radar connector plug as shown.

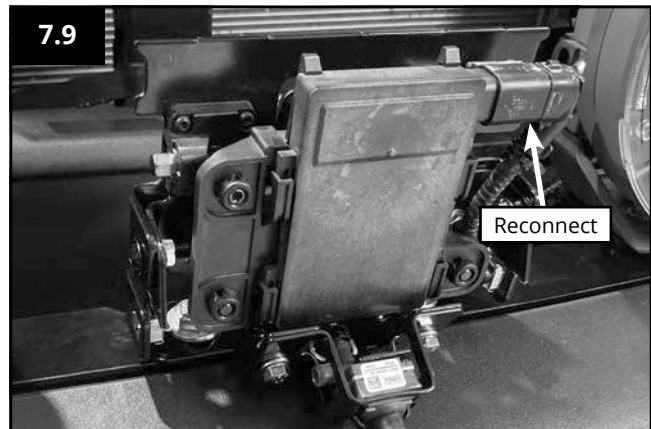

7.10 Place a level in front of the radar. Ensure that the radar is vertical. The front face should be 90 degrees level to the ground ± 1 deg.

NOTE: If the radar is not level, use 8mm socket, to turn the adjustment screw to achieve the correct angle.

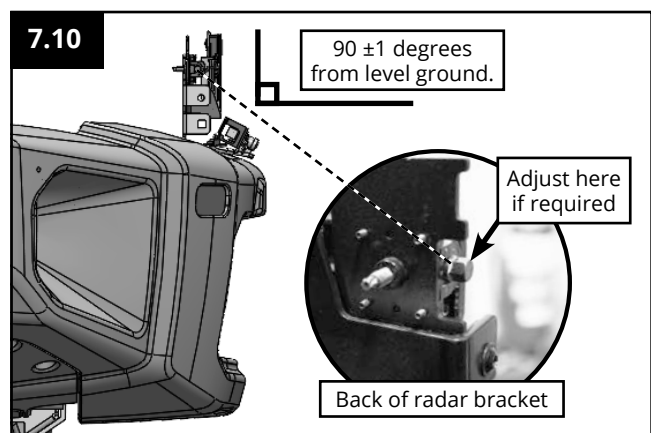

Camera Vehicles Only

7.11 Reconnect Coax extension to the vehicle.

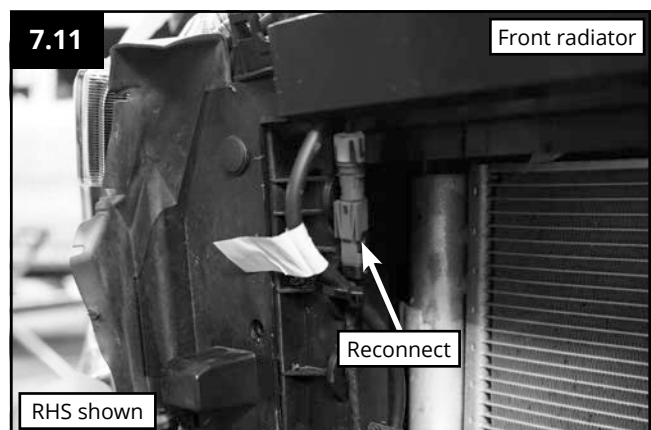

7.12 Reconnect the washer tube extension to the vehicle.

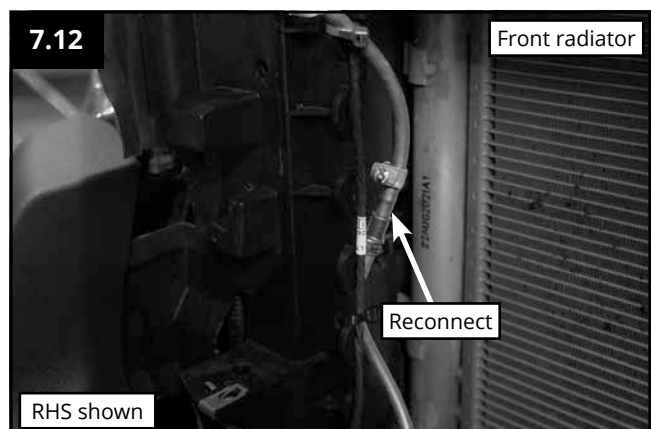

7.13 Place radar cover (290-CH) over the radar and camera.

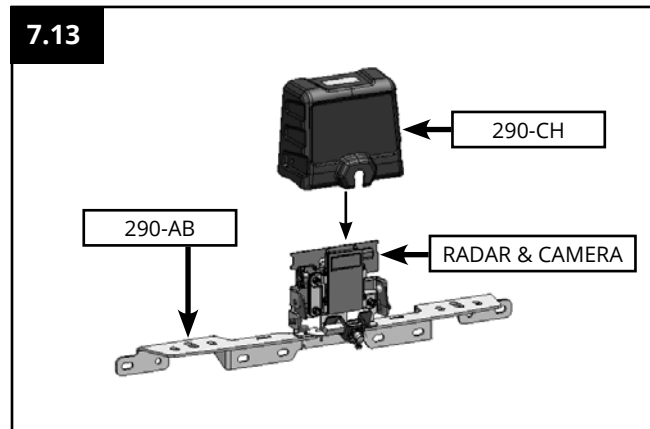

7.14 Using hardware shown mount the 290-CH to the radar bracket.

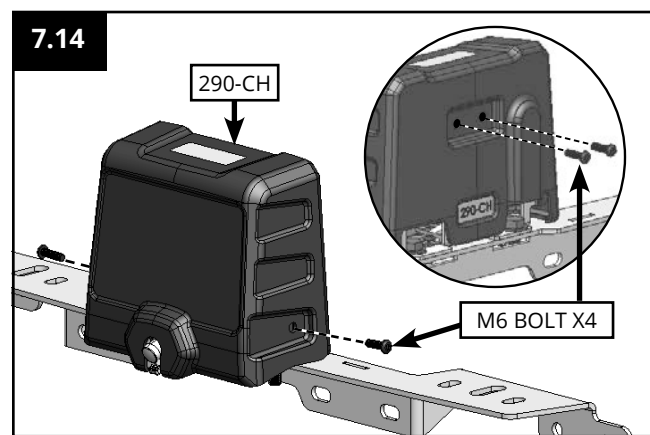

ARB Recovery Point Install Only

7.15 If installing an ARB Recovery Point, cut the underwing as shown.

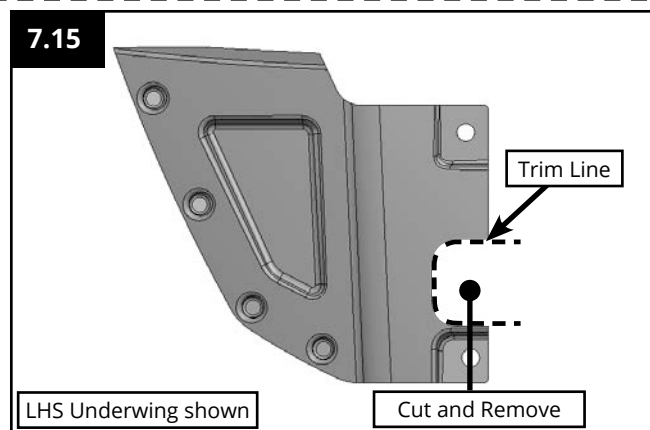

7.16 Secure the underwing to the vehicle by installing the hardware into the 290-BL and 290-UM as shown.

Leave loose.

Repeat on the other side.

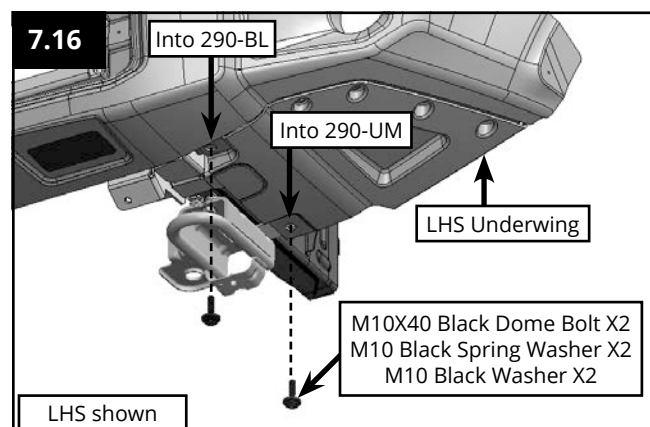

7.17 Mark a line on wheel arch liner from the underwing as shown and cut 10mm above the marked line. Discard offcut.

Repeat on the other side.

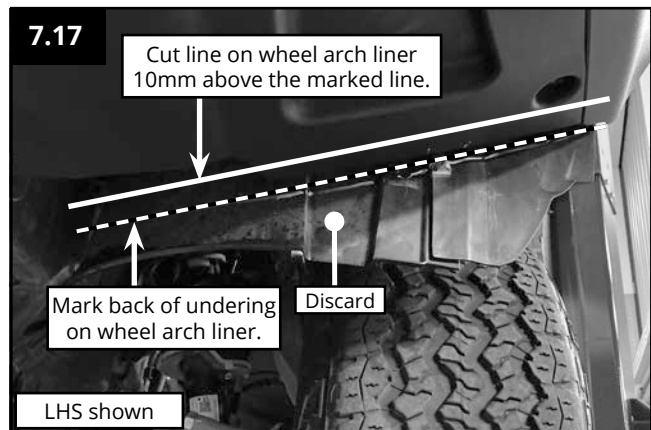

7.18 Cut wheel arch liner along line shown. Discard offcut.

Repeat on right hand side.

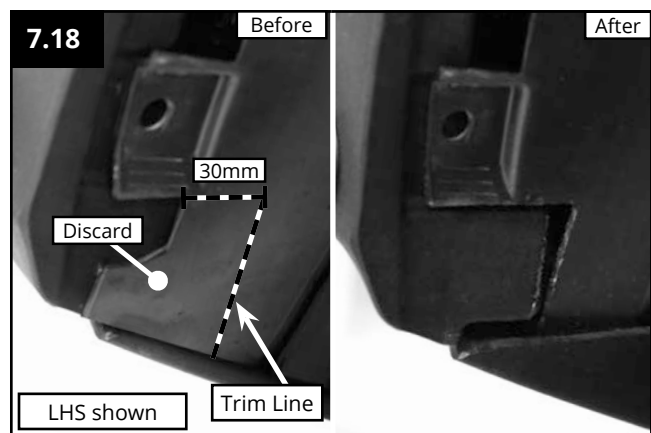

7.19 Tuck wheel arch liner into the underwing as shown.

Repeat on the right hand side.

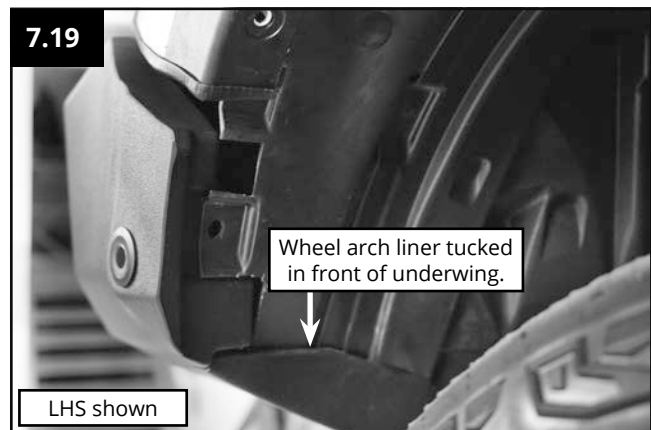

7.20 Install 290-WCL plate behind the wheel arch, using the hardware shown.

Note: Ensure the textured side is shown.

Repeat on right hand side with 290-WCR.

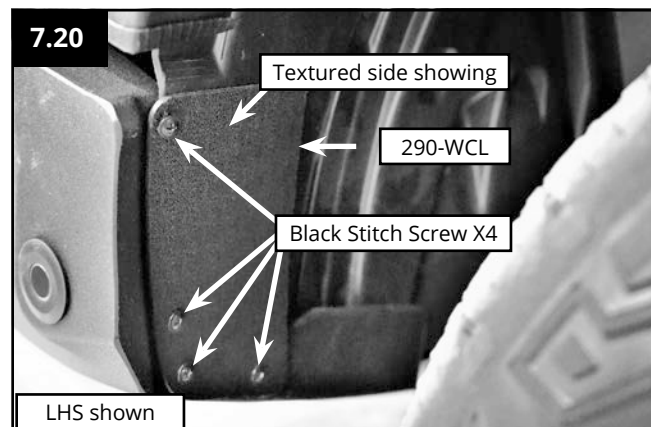

7.21 Align the underwing and mount to the bar using hardware shown.

Tighten underwing bolts (from step 7.18) to **25 Nm**.

Repeat on right hand side.

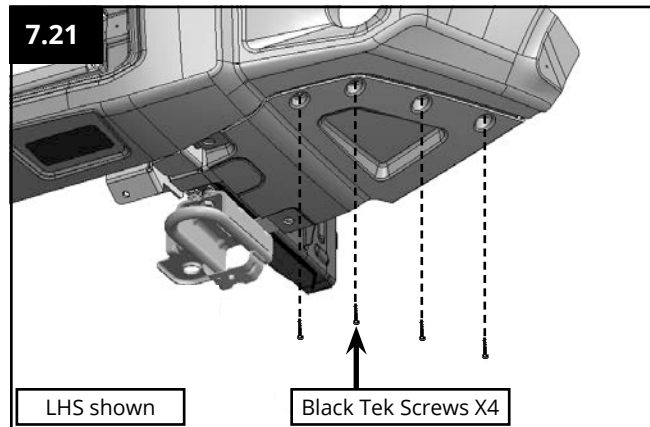

7.22 Install the 290-UC panel using the hardware shown and leave loose.

NOTE: UP005A shown for reference only

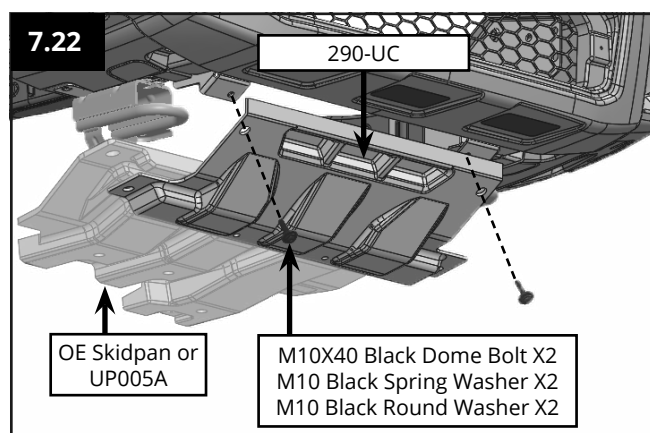

7.23 Install the 290-UC panel using the hardware shown and tighten all 290-UC bolts to 25Nm.

NOTE: UP005A shown for reference only

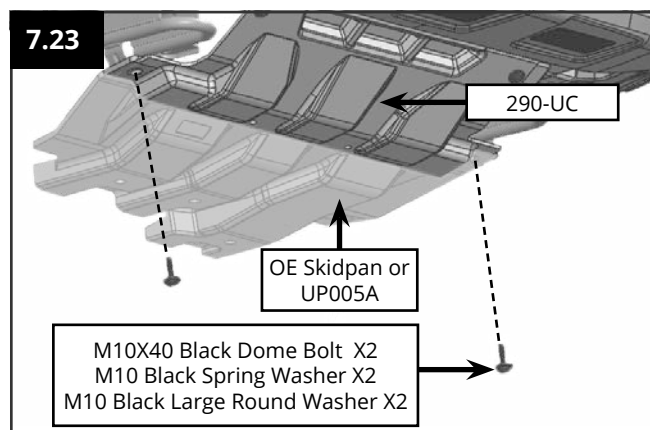

UVA UP005 Install Only

7.24 If fitting to UP005A, use the 290-UC holes shown in this step, to mark and drill 13mm diameter holes in the UP005A.

Install the 290-UC panel using the hardware shown.

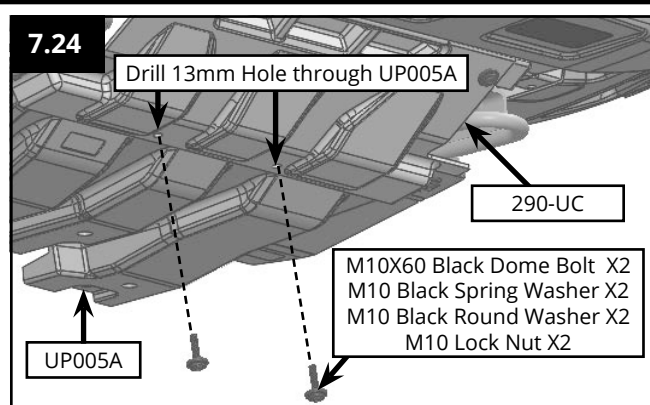

7.25 Re-connect the wiring connector at the top of the grille & secure as shown

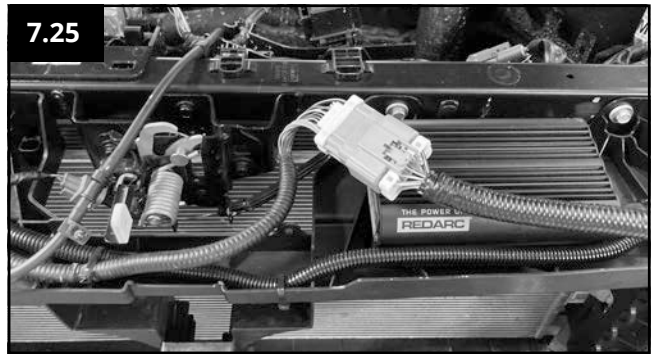

**FORD RANGER XL, XLS, XLT, SPORT
FORD EVEREST PLATINUM GRILLE ONLY.**

7.26a Rest the grille in place and align with the 290-GX. Mark and drill hole through the grille, where cage nuts are located on the 290-GX.

Re-Install grille to the vehicle and secure with hardware shown.

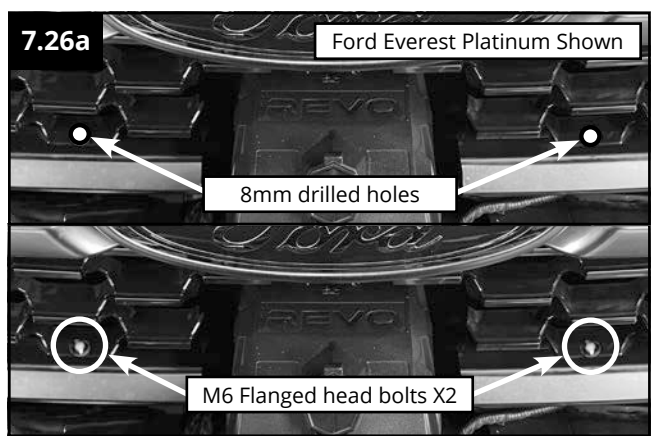

**FORD EVEREST AMBIENTE, TREND, SPORT
FORD RANGER WILDTRACK ONLY.**

7.26b Rest the grille in place and align with the 290-GB. Mark and drill hole through the grille, where cage nuts are located on the 290-GB.

Re-Install grille to the vehicle and secure with hardware shown.

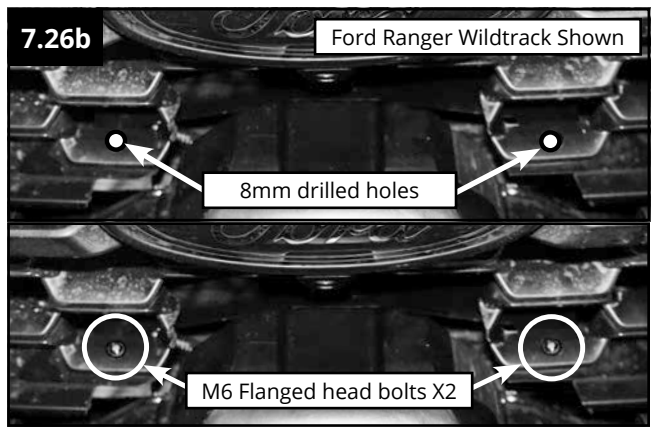

7.27 Install the grille top cover using the scriveners removed.

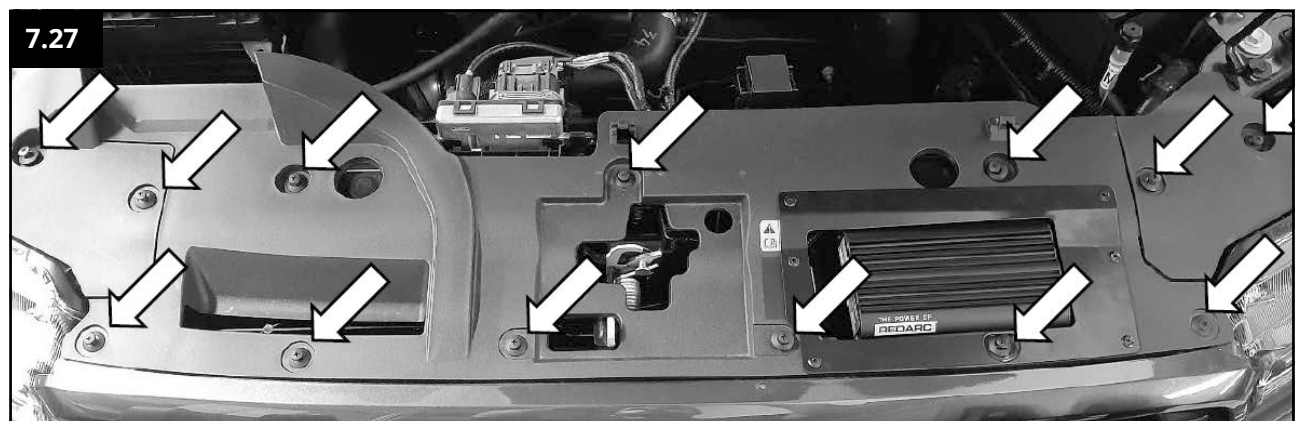

Step 8 : Number Plate Install

Standard Kit Only

8.1 Mount the license plate to the bar.

NOTE: Ensure that it is aligned centrally and is level to the bar.

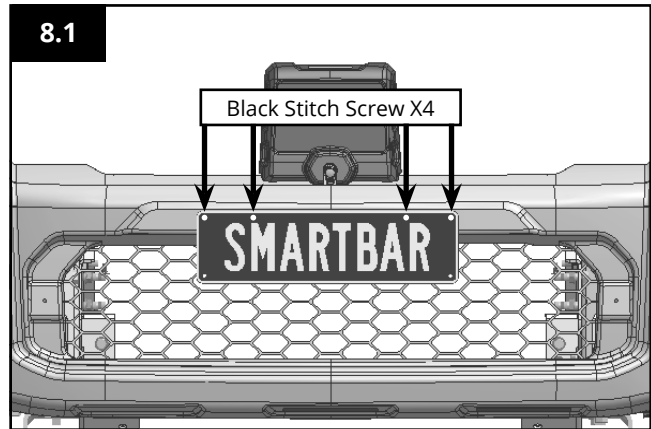

Winch Kit Only

Number plate hinge bracket, supplied with winch kit .

8.2 Fit 290-NL onto 290-NB using hardware as shown.

Leave hardware loose.

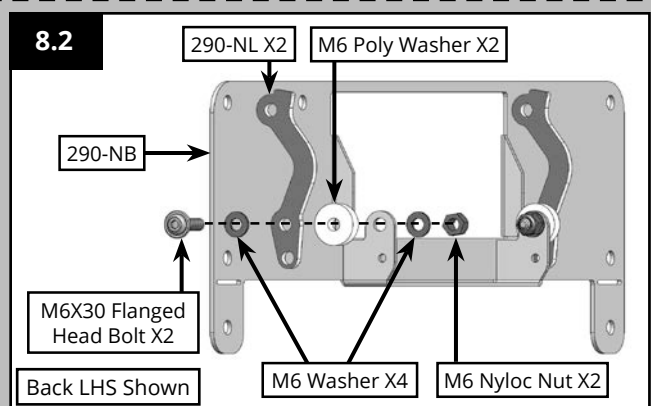

8.3 Fit 290-NL onto 290-NT using hardware as shown.

Tighten each side evenly until movement is firm.

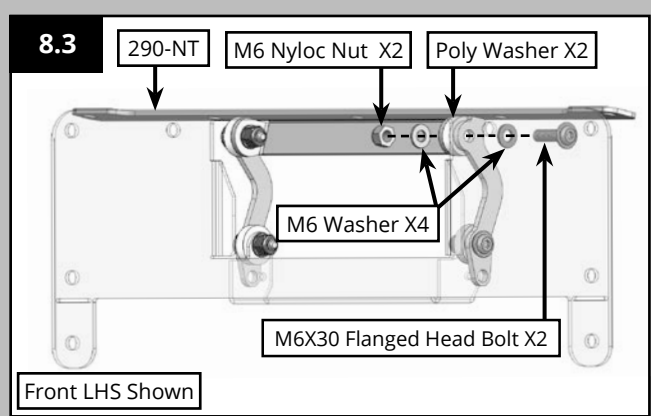

8.4 Install M8 plungers to to the 290-NL with hardware as shown.

NOTE: Ensure that ball spring engages with 290-NB

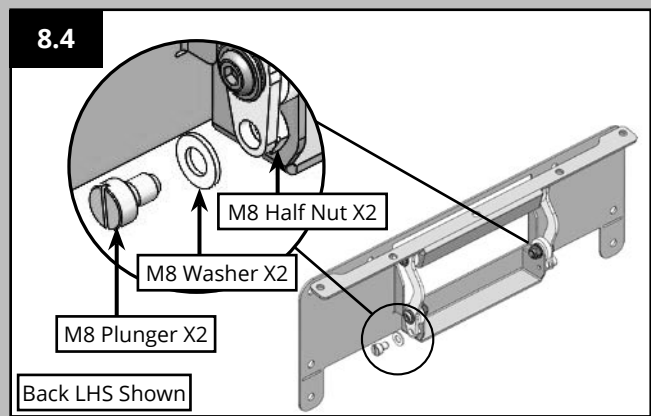
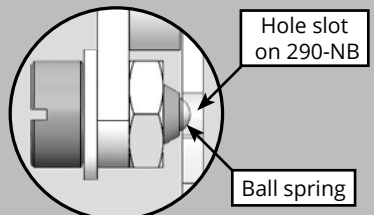

Winch Kit Only

8.5 If you are fitting a full-sized plate, proceed to step 8.7

If you are fitting a slim line plate, use the laser cut grooves as a guide. Carefully cut the lower section of the pivot plate (290-NB) and discard.

8.6 Use a file to remove any sharp edges,

NOTE: Use matte black enamel paint to touch up the cut surface to prevent rust.

8.7 Attach number plate to the pivot bracket assembly. Tighten to specified torque

M6 Fasteners: **Max 9 Nm.**

8.8 With number plate bracket in locked position, centralise the bracket and ensure license plate is parallel to front of the bar.

Mount the Assembled bracket to the bar using hardware supplied as shown.

Installation complete.

8.5

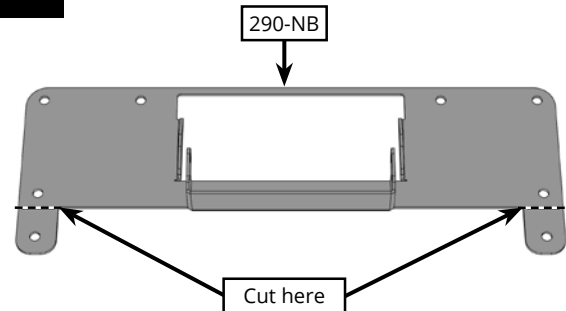

8.6

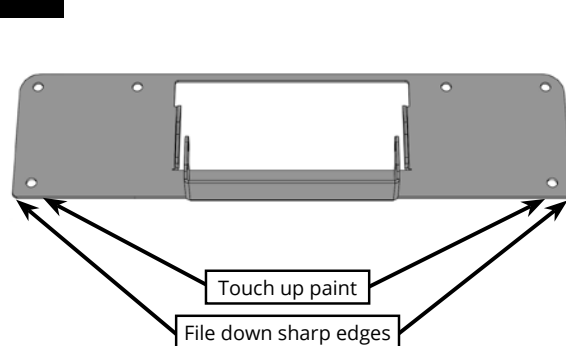

8.7

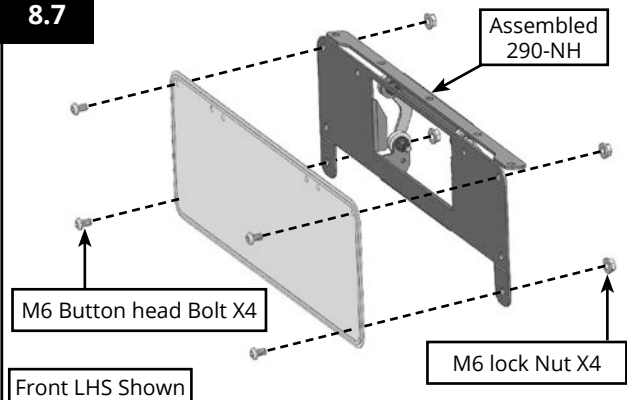

8.8

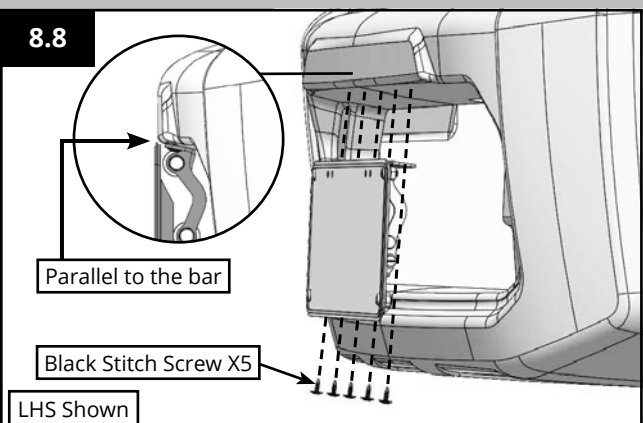

Fitted Product Checks

Important Checks once the StealthBar is fitted.

- Ensure all bolts are tensioned correctly
- All wiring is clear of sharp edges or moving surfaces and is secured correctly.
- Check operation of winch if fitted
- Check all wiring and connections to turn signal lamps, parking sensors, camera washers and any other functioning components that may have been altered during the installation.

Vehicles Equipped With A Front Facing Camera

- During the daytime, drive on a straight road with clear line markings at 12-35kph for around 10 minutes to recalibrate the camera operation. Avoid steering as this increases the time to calibrate.
- Stop the vehicle and check the 360 degree camera view has completed stitching.
- Put the vehicle in reverse and confirm there is no "RBA Not Available" warning.
- If stitching is not completed or "RBA Not Available" warning persists, repeat the calibration drive.

Install Complete.



BOXED BAR CONTENTS

SA290BL290 - Standard Kit, Non-Parking Sensor Bar

Code	Description	Qty	OK
N/A	SA290BLASSY	1	
BP80714	290-GC (ABS COVER PLATE)	1	
SA290URBL	290-UR (Underwing Right)	1	
SA290ULBL	290-UL (Underwing Left)	1	
SA290UC	290-UC (Under Centre)	1	
SA290HIL	290-HR (Headlight Infill Right)	1	
SA290HIR	290-HL (Headlight Infill Left)	1	
SA290GL	290-GR (Grille Infill Right)	1	
SA290GR	290-GL (Grille Infill Left)	1	
SA290HWK	SA290 Hardware Kit	1	
SA290BKA	SA290 Bracket Kit N Winch	1	
Packed By		Date	

SA290BL291 - Winch Kit, Non-Parking Sensor Bar

Code	Description	Qty	OK
N/A	SA290BLASSY	1	
SA290URBL	290-UR (Underwing Right)	1	
SA290ULBL	290-UL (Underwing Left)	1	
SA290UC	290-UC (Under Centre)	1	
SA290HIL	290-HR (Headlight Infill Right)	1	
SA290HIR	290-HL (Headlight Infill Left)	1	
SA290GL	290-GR (Grille Infill Right)	1	
SA290GR	290-GL (Grille Infill Left)	1	
SA291HWK	SA291 Hardware Kit	1	
SA291BKA	SA291 Bracket Kit Winch	1	
Packed By		Date	

SA292BL290 - Standard Kit, Parking Sensor Bar

Code	Description	Qty	OK
N/A	SA292BLASSY	1	
BP80714	290-GC (ABS COVER PLATE)	1	
SA290UR	290-UR (Underwing Right)	1	
SA290UL	290-UL (Underwing Left)	1	
SA290UC	290-UC (Under Centre)	1	
SA290HIL	290-HR (Headlight Infill Right)	1	
SA290HIR	290-HL (Headlight Infill Left)	1	
SA290GL	290-GR (Grille Infill Right)	1	
SA290GR	290-GL (Grille Infill Left)	1	
SA290HWK	SA290 Hardware Kit	1	
SA290BKA	SA290 Bracket Kit N Winch	1	
Packed By		Date	

SA292BL291 - Winch Kit, Parking Sensor Bar

Code	Description	Qty	OK
N/A	SA292BLASSY	1	
SA290UR	290-UR (Underwing Right)	1	
SA290UL	290-UL (Underwing Left)	1	
SA290UC	290-UC (Under Centre)	1	
SA290HIL	290-HR (Headlight Infill Right)	1	
SA290HIR	290-HL (Headlight Infill Left)	1	
SA290GL	290-GR (Grille Infill Right)	1	
SA290GR	290-GL (Grille Infill Left)	1	
SA291HWK	SA291 Hardware Kit	1	
SA291BKA	SA291 Bracket Kit Winch	1	
Packed By		Date	

BOXED BAR COMPONENT(S)

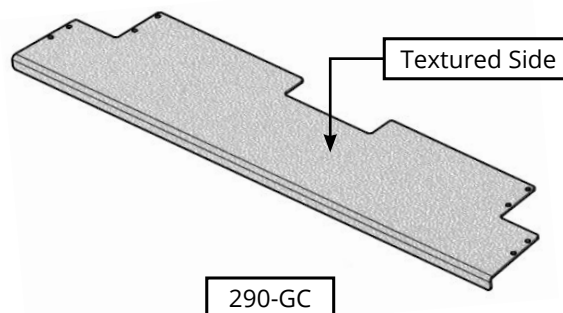

SA290BLASSY - Non-Parking Sensor Bar

Code	Description	Qty	OK
MK51058	SA290 Moulded Bar	1	
MM81154	290-MC (Mesh)	1	
BP80727	Badge ARB 77x35mm Lensed B130H	1	
BP1279	Screw 10X1G Phil Self Tap	8	
BP38781	Screw Stitch 8GX15mm Eco Black	14	
N/A	141-LI	2	
Packed By		Date	

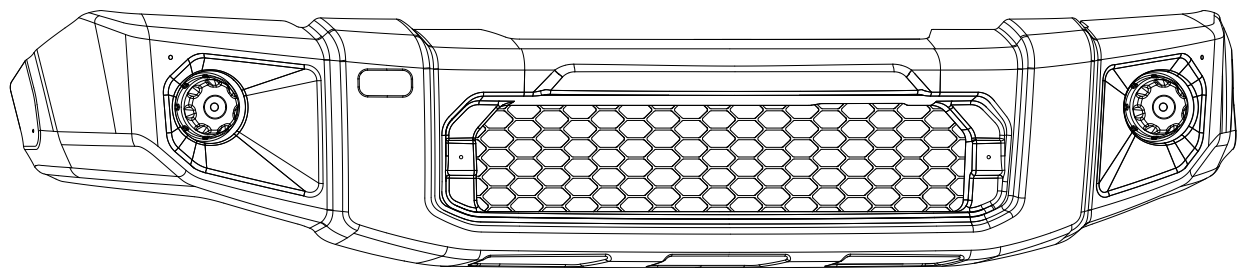
SA292BLASSY - Parking Sensor Bar

Code	Description	Qty	OK
MK51058	SA290 Moulded Bar	1	
MM81154	290-MC (Mesh)	1	
BP80727	Badge ARB 77x35mm Lensed B130H	1	
BP1145	8-15X15 Button Head NICKEL SCR	16	
BP38781	Screw Stitch 8GX15mm Eco Black	14	
SA292PSK	SA292 Parking Sensor Kit	1	
BP80557	LED FOG / DRL Light Kit	1	
BP80728	290-LI	2	
MM81166	290-FL	4	
Packed By		Date	

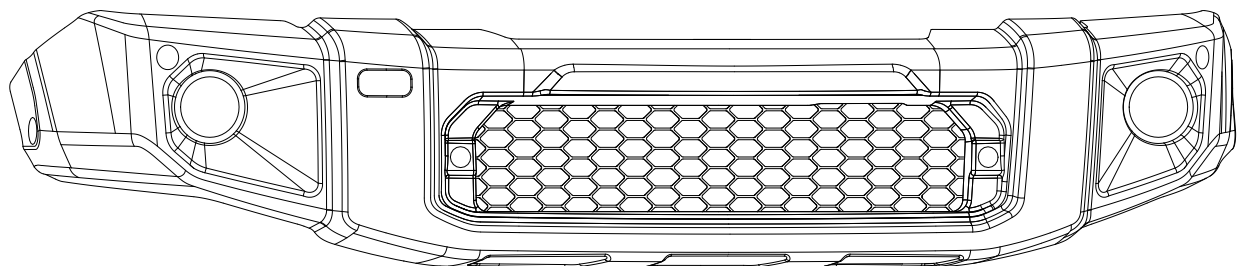

SA290BKA (Standard Kit)

Code	Description	Qty	OK
MM81136	290-BR (BAR BRACKET RHS)	1	
MM81137	290-BL (BAR BRACKET LHS)	1	
MM81138	290-CR (CHASSIS BRACKET RHS)	1	
MM81139	290-CL (CHASSIS BRACKET LHS)	1	
MM81140	290-CT (CRUSH TUBE)	2	
MM81141	290-LR (LOWER SIDE BRACKET RHS)	1	
MM81142	290-LL (LOWER SIDE BRACKET LHS)	1	
MM81145	290-TR (TOP SIDE BRACKET RHS)	1	
MM81146	290-TL (TOP SIDE BRACKET LHS)	1	
MM81147	290-UM (UNDERWING MOUNT BRACKET)	2	
MM81150	291-AB (ACCESSORIES BRACKET)	1	
MM81152	290-GB (GRILL REINFORCEMENT BRACKET)	1	
MM81153	290-SB (MIDDLE SUPPORT BRACKET)	1	
MM81148	290-AML (STEALTH AERIAL MOUNT LEFT)	1	
MM80854	190-ABS (SPOTLIGHT SPACER PLATE)	1	
MM81164	290-RL (BUMPER RETAINER BRACKET LHS)	1	
MM81165	290-RR (BUMPER RETAINER BRACKET RHS)	1	
Packed By		Date	

SA291BKA (Winch Kit)

Code	Description	Qty	OK
MM81136	290-BR (BAR BRACKET RHS)	1	
MM81137	290-BL (BAR BRACKET LHS)	1	
MM81138	290-CR (CHASSIS BRACKET RHS)	1	
MM81139	290-CL (CHASSIS BRACKET LHS)	1	
MM81140	290-CT (CRUSH TUBE)	2	
MM81141	290-LR (LOWER SIDE BRACKET RHS)	1	
MM81142	290-LL (LOWER SIDE BRACKET LHS)	1	
MM81145	290-TR (TOP SIDE BRACKET RHS)	1	
MM81146	290-TL (TOP SIDE BRACKET LHS)	1	
MM81147	290-UM (UNDERWING MOUNT BRACKET)	2	
MM81150	291-AB (ACCESSORIES BRACKET)	1	
MM81152	290-GB (GRILL REINFORCEMENT BRACKET)	1	
MM81148	290-AML (STEALTH AERIAL MOUNT LEFT)	1	
MM80854	190-ABS (SPOTLIGHT SPACER PLATE)	1	
MM81164	290-RL (BUMPER RETAINER BRACKET LHS)	1	
MM81165	290-RR (BUMPER RETAINER BRACKET RHS)	1	
MM81173	290-NT (NUMBER PLATE HINGE TOP)	1	
MM81174	290-NL (NUMBER PLATE HINGE LINK)	2	
MM81175	290-NB (NUMBER PLATE HINGE BODY)	1	
MM81144	290-OL (OUTER REINFORCEMENT LHS)	1	
MM81143	290-OR (OUTER REINFORCEMENT RHS)	1	
MM81151	291-WB (WINCH BRACKET)	1	
Packed By		Date	

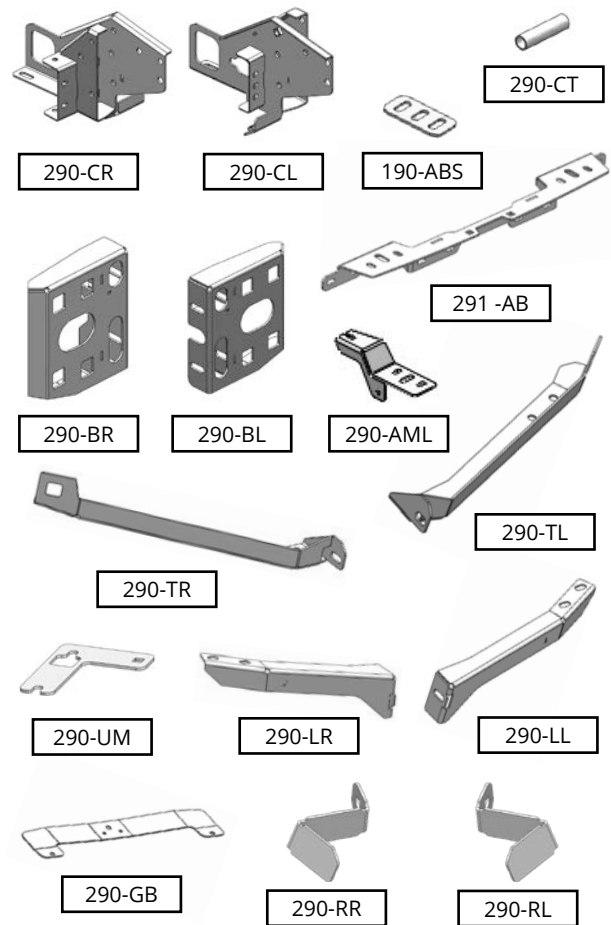
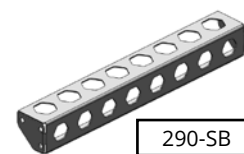
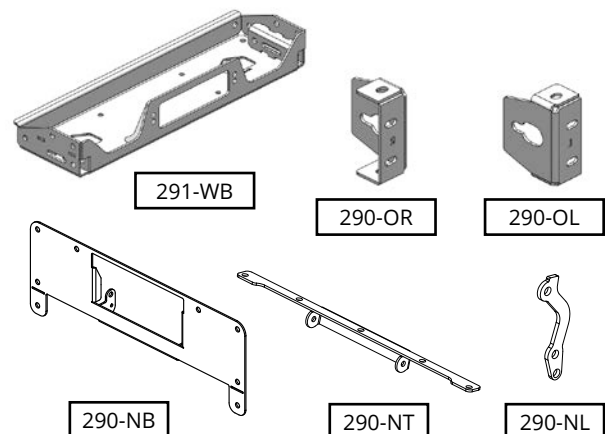
COMMON COMPONENTS

STANDARD KIT COMPONENTS

WINCH KIT COMPONENTS

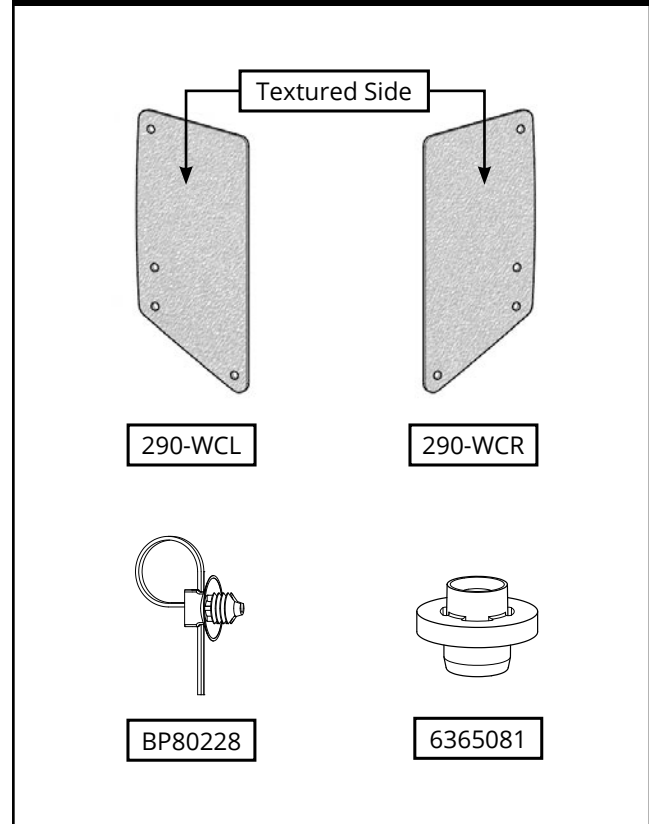
SA290HWK STANDARD HARDWARE KIT

Code	Description	Qty	OK
BP80714	290-GC (ABS COVER PLATE)	1	
BP80720	290-WCL	1	
BP80721	290-WCR	1	
BP1024	12 X 30 M88ZPB HEX CAD BOLT	10	
6152066	12 X 50 G10.9 M88ZPB HEX CAD BOLT	4	
MM1244	12X40X40X5ZPG SQUARE WASHER	10	
BP1140	12MSW M12 ZINC PLT SPRING WASHER	10	
BP1017	M10 X 30 M88ZPB HEX CAD BOLT	26	
BP80496	BOLT M10X100 8.8 ZP HEX	4	
BP80592	10X40 TZP BHSS BOLT BLACK 480	8	
BP80593	10X60 TZP BHSS BOLT BLACK 480	2	
BP1093	10MZPW M10 WASHER	30	
BP1125	10MWLNBU M10 WIZ LOCK NUT	20	
BP1139	10MSW ZINC PLT SPRING WASH	6	
BP80542	M10 FLAT WASHER M10X30X4 BLACK	10	
BP38750	M10 WASHER SPRING ECO BLACK	10	
BP80608	M10 CAGE NUT ZP	2	
BP80613	M6 CAGE NUT ZP SUIT 1.6-2MM	2	
BP80725	BOLT HXHD FL M8x1.25x20	10	
BP80726	WASHER FLAT M8x26x4	10	
BP80412	NUT M8 WIZLOCK 8MWLN ZP	4	
BP80388	SCASE BOLT M6X20 TZNB FHEAD	3	
BP2010	TANK SCREW 12-11X45MM	8	
BP38781	SCREW STITCH 8GX15MM ECO BLACK	14	
BP1145	8-15X15 BUTTON HEAD NICKLE SCR	22	
BP1124	6MWLNBU M6 WIZ LOCK NUT	3	
6365081	INTERCOOLER ISOLATING BUSH	2	
BP80228	RETAINER FUEL LINE	5	
BP24784	PINCHWELD #NINVF PW21	0.35	
BP24784	PINCHWELD #NINVF PW21	0.35	
BP80698	30x80MM DOUBLE SIDED TAPE 2	2	
6602018	ALCOHOL SWAB SINGLE SACHET 1	1	
665044	3M PRIMER AMPULE 1	1	
BP1191	56404 Cable Ties (100)	10	
N/A	SA290-BTT FORD P703 2022	1	
Packed By		Date	

SA290HWK HARDWARE KIT

SA291HWK HARDWARE KIT			
Code	Description	Qty	OK
BP80720	290-WCL	1	
BP80721	290-WCR	1	
BP1024	12 X 30 M88ZPB HEX CAD BOLT	16	
6152066	12 X 50 G10.9 M88ZPB HEX CAD BOLT	4	
BP1094	12MZPW M12 WASHERS	6	
MM1244	12X40X40X5ZPG SQUARE WASHER	10	
BP1140	12MSW M12 ZINC PLT SPRING WASHER	10	
BP80313	M12 FLANGE W/LOCK NUT	6	
BP1017	M10 X 30 M88ZPB HEX CAD BOLT	22	
BP80496	BOLT M10X100 8.8 ZP HEX	4	
BP80592	10X40 TZP BHSS BOLT BLACK 480	8	
BP80593	10X60 TZP BHSS BOLT BLACK 480	2	
BP1093	10MZPW M10 WASHER	26	
BP1125	10MWLNBU M10 WIZ LOCK NUT	16	
BP1139	10MSW ZINC PLT SPRING WASH	6	
BP80542	M10 FLAT WASHER M10X30X4 BLACK	10	
BP38750	M10 WASHER SPRING ECO BLACK	10	
BP80608	M10 CAGE NUT ZP	2	
BP80613	M6 CAGE NUT ZP SUIT 1.6-2MM	2	
BP80724	8X50MZPN HEX ZINC BLK Fhead BOLTS	4	
BP80725	BOLT HXHD FL M8x1.25x20	6	
BP80726	WASHER FLAT M8x26x4	10	
BP80412	NUT M8 WIZLOCK 8MWLN ZP	8	
BP2010	TANK SCREW 12-11X45MM	8	
BP38781	SCREW STITCH 8GX15MM ECO BLACK	10	
BP1145	8-15X15 BUTTON HEAD NICKLE SCR	14	
BP80388	SCASE BOLT M6X20 TZNB FHEAD	3	
BP1124	6MWLNBU M6 WIZ LOCK NUT	3	
6365081	INTERCOOLER ISOLATING BUSH	2	
BP80228	RETAINER FUEL LINE	5	
BP24784	PINCHWELD #NINVF PW21	0.35	
BP24784	PINCHWELD #NINVF PW21	0.35	
BP80698	30x80MM DOUBLE SIDED TAPE 2	2	
6602018	ALCOHOL SWAB SINGLE SACHET 1	1	
665044	3M PRIMER AMPULE 1	1	
BP1191	56404 CABLE TIES (100)	16	
N/A	SA290-BTT Ford Ranger P703 2022	1	
Packed By		Date	

