

ARB **BED RACK**

Product Description: **BED RACK SIDE CHANNEL**

WARNING

NOTE THE FOLLOWING:

- ◆ Vehicle accessories which are not properly fitted can be dangerous.
- ◆ Please read these instructions carefully prior to fitting, and comply with the instructions at all times.
- ◆ If in any doubt please contact your nearest ARB state office or the stockist from whom it was purchased.
- ◆ Do not use this product for any vehicle make or model, other than those specified by ARB.
- ◆ This product or its fixing must not be modified in any way.
- ◆ The installation of this product may require the use of specialized tools and/or techniques.
- ◆ It is recommended that this product is only installed by trained personnel.
- ◆ These instructions are correct as at the publication date. ARB Corporation Ltd. cannot be held responsible for the impact of any changes subsequently made by the vehicle manufacturer.
- ◆ During installation, it is the duty of the installer to check correct operation/clearances of all components.
- ◆ Work safely at all times.
- ◆ Unless otherwise instructed, tighten fasteners to specified torque.
- ◆ Check bolt torque after 500km & at regular service intervals.

ARB 4x4 ACCESSORIES

Corporate Head Office

42-44 Garden St
Kilsyth, Victoria
AUSTRALIA 3137

Tel: +61 (3) 9761 6622
Fax: +61 (3) 9761 6807

Australian enquiries
North & South American enquiries
Other international enquiries

sales@arb.com.au
sales@arbusa.com
exports@arb.com.au

www.arb.com.au

SAFETY

- ◆ The maximum load per channel is **12.5kg**.
- ◆ The load must be evenly distributed along the length of the channel.
- ◆ Load must **not** be concentrated in the middle section of the channel.
- ◆ Any weight carried on the BED RACK will adversely affect its handling, particularly in cornering or in a cross-wind, the vehicle should therefore be driven with increased discretion.
- ◆ Regularly check the tightness of the securing clamps and the security of the load.
- ◆ If accessories are attached to the bed rack, at least one cross bar must be fitted at all times.

GENERAL CARE AND MAINTENANCE

By choosing an ARB BED RACK, you have bought a product that is one of the most sought after 4WD products in the world. Your BED RACK is a properly engineered, reliable, quality accessory that represents excellent value. To keep your BED RACK in original condition it is important to care and maintain it following these recommendations:

- As part of any pre-trip preparation, or on an annual basis, it is recommended that a thorough visual inspection of the BED RACK is carried out, making sure that all bolts and other components are torqued to the correct specification. Replace any components as necessary.

Please contact local Authorised ARB Stockist if you would like to have this service carried out on your behalf.

FITTING REQUIREMENTS

REQUIRED TOOLS FOR FITMENT OF PRODUCT:

METRIC SOCKET SET	Tape measure
TORQUE WRENCH Minimum 22Nm	

FASTENER TORQUE SETTINGS:

SIZE	Torque Nm	Torque lbft
M8	22Nm	16lbft

PARTS LISTING – BED RACK CROSS BAR FITTING KIT

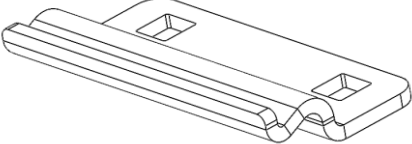
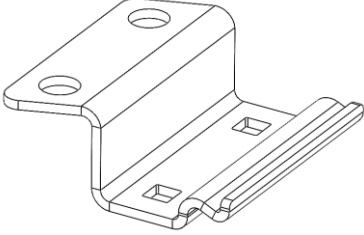
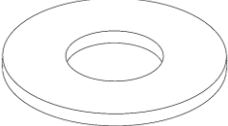
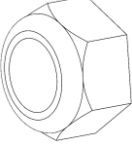
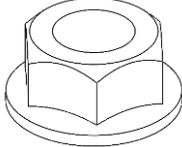
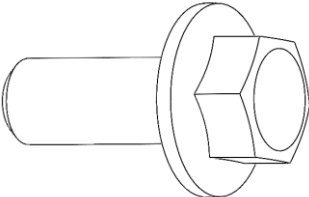
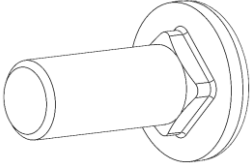
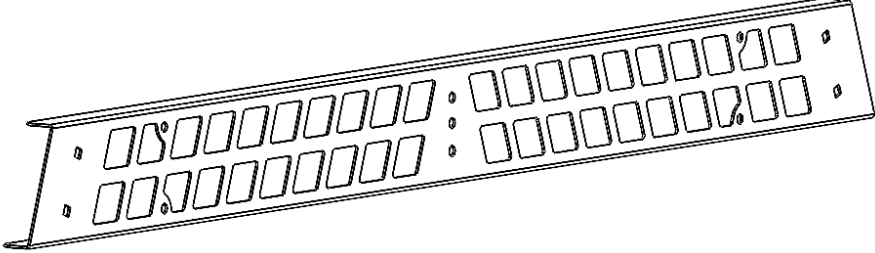
PART NUMBER	DESCRIPTION	QTY	DIAGRAM
3755341	BRKT RT ACC CLAMP 75MM	2	
3755344R/ L	SIDE ACC BRKT RH/LH	1R/1 L	
4581085	WASHER FLAT M8X19X1.2	8	
6151212	NUT HEX NYLOC M8X1.25	8	
6151548	NUT FLANGE M8x1.25	2	
6151730	BOLT HXHD FL M8x1.25x20	2	
6151921	BOLT COHD M8X20	8	
VEHICLE SPECIFIC	SIDE MNT CHANNEL	1	

BEFORE STARTING, READ ALL STEPS OF THE INSTRUCTIONS

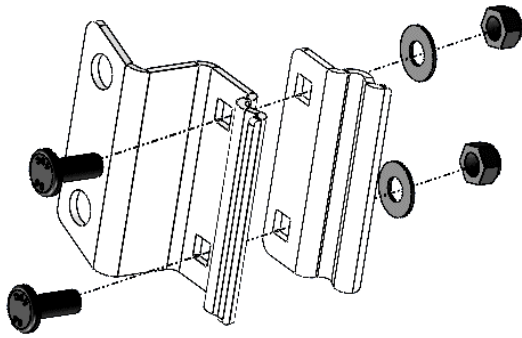

1. Install M8 coach head screws, washers and nyloc nuts through clamping brackets as shown.
Leave finger tight.

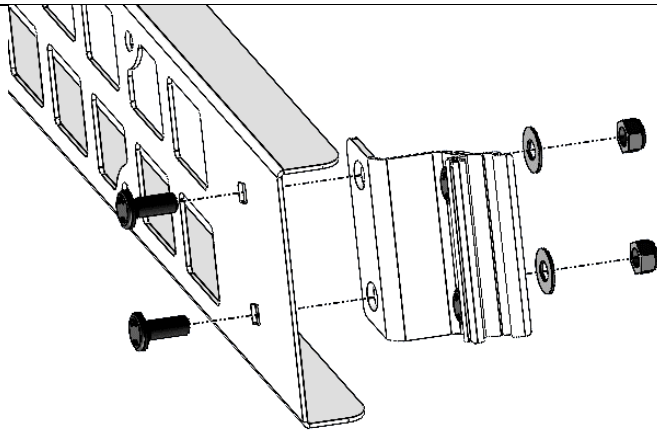

2. Install brackets onto both ends of side channel.
Leave finger tight.

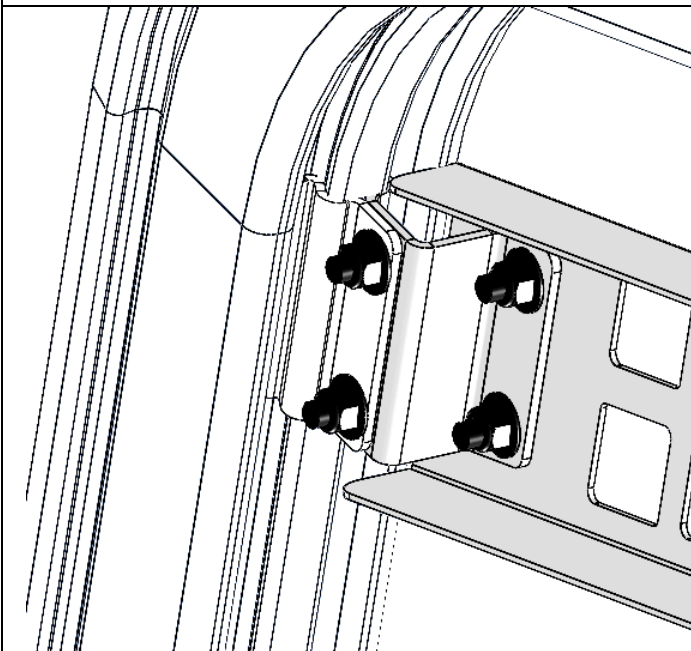

3. Install bracket assembly onto bed rack by placing clamping brackets onto the inside dovetail of frame.
4. Ensure side channel is sitting parallel to the top of the vehicle tub and there is an even space above and below. Torque all fasteners to specification.

 M8 - 22 Nm.

SIDE CHANNEL TWIN FITMENT

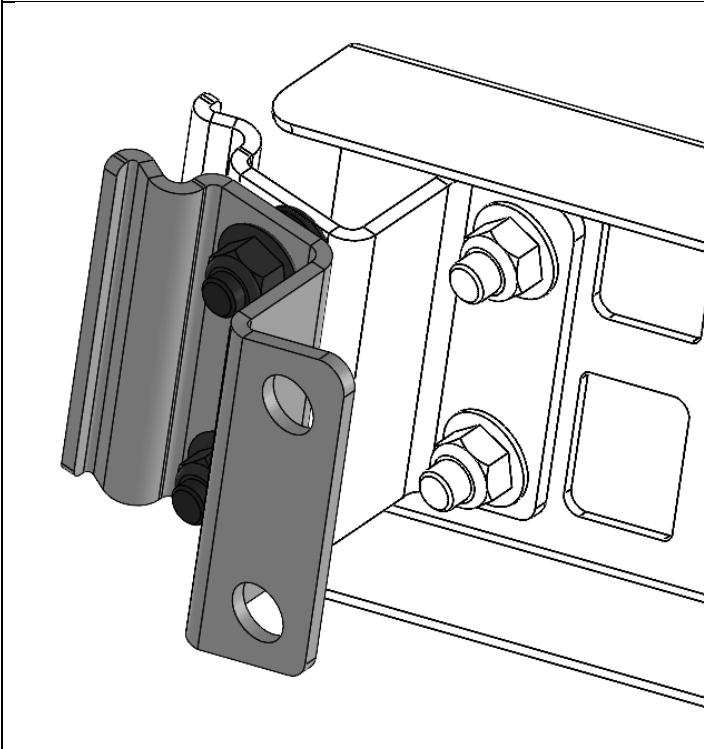

1. If fitted to BED RACK, remove one clamp 3755341 and replace with clamping bracket 3755344 R or L, torque to specification.

 M8 - 22 Nm.

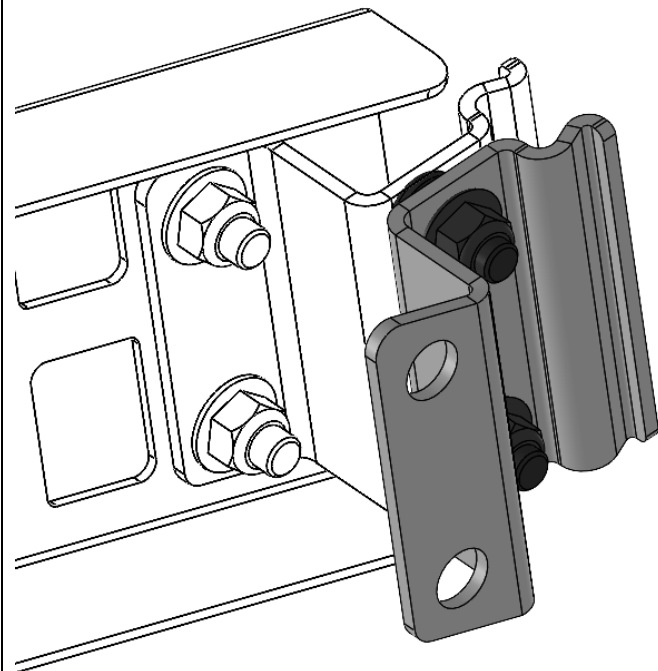

2. Repeat step 1. at opposite end.

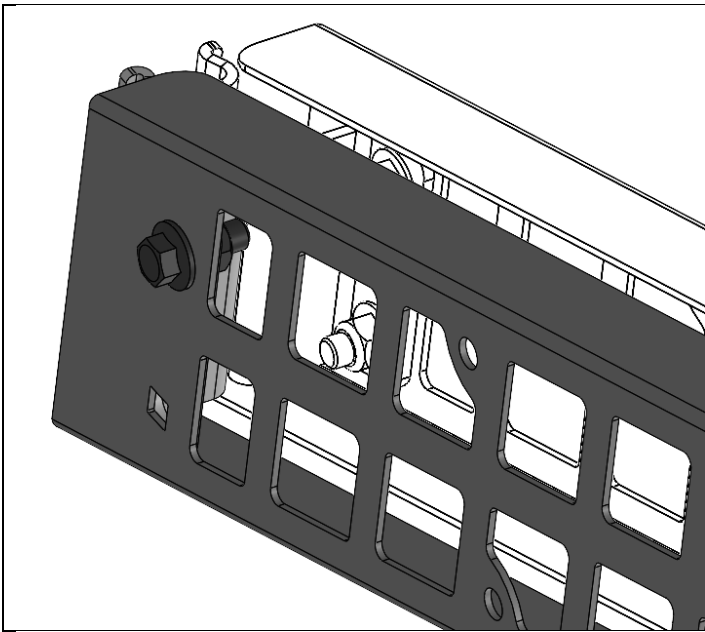

3. Using an M8 flange bolt and flange nut, loosely fit the SIDE CHANNEL to the mount.

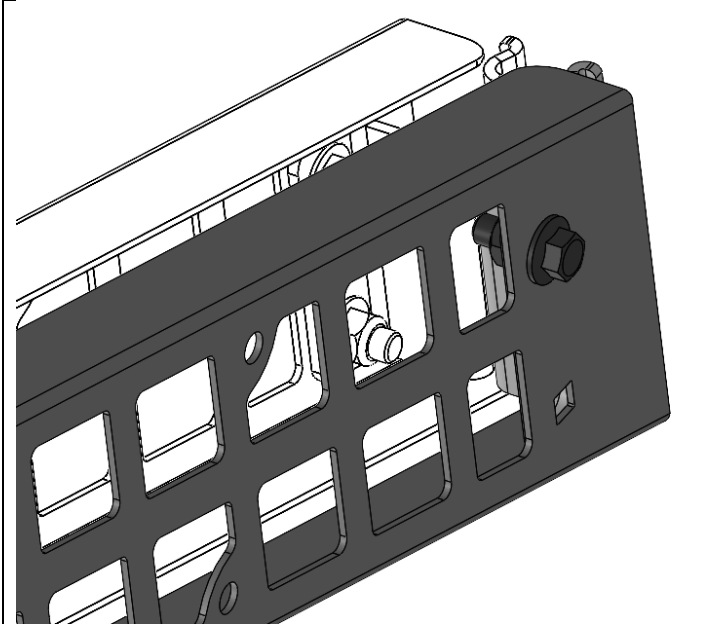

4. Repeat step 3. at opposite end.

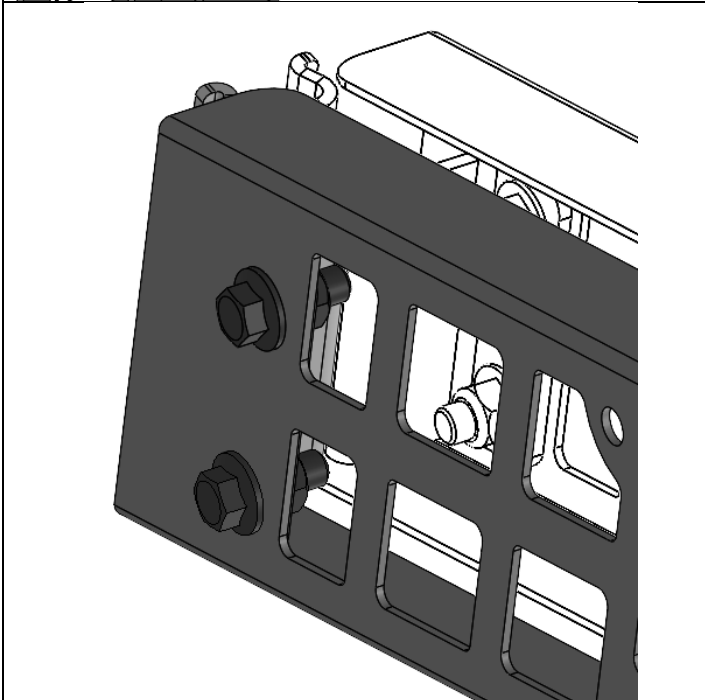

5. Assemble an extra flange bolt and flange nut at each end.
6. Align the top edges of each channel and torque to specification.

 M8 - 22 Nm.

FITTED PRODUCT

