

ALTITUDE ROOF TOP TENT

804500 - SOLAR PANEL INSTALLATION-ROOF TOP TENT



SAFETY

NOTE THE FOLLOWING:

- ◆ Please read these instructions carefully prior to installation and comply with the instructions at all times
- ◆ If in any doubt, please contact your nearest ARB state office or the stockist from whom it was purchased.
- ◆ Do not use this product for any other accessory fitment, other than for its use as specified by ARB.
- ◆ This product or its fixing must not be modified in any way as will void warranty.
- ◆ It is recommended that this product is only installed by trained personnel
- ◆ Fitment can be undertaken with one person, however due to the weight of the Rooftop Tent, it is advised lifting aids are used to lift it into position.
- ◆ During installation, it is the duty of the installer to check the correct operation/clearance of all components
- ◆ Work safely always
- ◆ Unless otherwise instructed, tighten fasteners to the specified torque
- ◆ Check bolt torque after 500km & at regular service intervals

Please provide a copy of this instruction to the customer

ARB 4x4 ACCESSORIES

Corporate Head Office

42-44 Garden St
Kilsyth, Victoria
AUSTRALIA 3137

Tel: +61 (3) 9761 6622
Fax: +61 (3) 9761 6807

Australian enquiries
North & South American enquiries
Other international enquiries

sales@arb.com.au
sales@arbusa.com
exports@arb.com.au

www.arb.com.au

!! CUSTOMER - SAFETY NOTICE !!

- **DO NOT** drive with tent side locks unlocked. These **MUST** be Key locked while driving.
- This product **weighs 105kg (with ladder stored in roof)**, when fitted to this mounting system.
- **The roof bars on top of the tent are rated to 20Kg payload only. DO NOT exceed this payload. If the tent does not open it is likely to be because the payload has been exceeded. (Maximum weight of tent with payload is 125kg).**
- **If a solar panel is fitted no additional load can be carried on the roof top tent's roof bar rails.**
- Be aware of the height that is added to your vehicle including that of any load as attached to the rooftop tent's roof bars. **Drive being aware of height limits and vehicle handling conditions.**
- With the tent fitted and also with this solar panel accessory, this will affect the vehicles cross wind sensitivity, cornering and braking characteristics. **Driving techniques should be altered to suit, by reducing corner speed and increasing braking distance and by driving at a speed safely depending on your control of the vehicle's handling conditions.**
- **DO NOT** make any modifications to locks on the tent or any tent mounting systems or any mounting systems of the accessories.
- ARB recommends only fitting ARB approved accessories, designed for your tent.

!! WARNING !!

This 120 W Solar panel is unregulated and requires terminating to either a standalone solar regulator or REDARC BCDC unit equipped with an inbuilt solar regulator prior to connection to battery

IMPORTANT:

CARE AND USE OF YOUR ALTITUDE ROOFTOP TENT:

Please refer to the "Owner's Manual for the Roof Top Tent" contained within the Fitting Kit of the Tent. (Part number 37801296).

SAFETY:

ARB Blade bracket kits for the ARB Altitude Roof Top Tent **MUST** be fitted to the vehicle model as is specified.

TOOL LIST FOR FITMENT:

Step Drill	Battery drill
Pen/pencil	Wire Strippers
12mm hole saw	Socket set
Torque wrench	Rivet tool
Jab/dry wall hand saw	Metal File
2 quick lock G clamps	Drill bit set to include 5.2mm

NOTE: 'WARNING' notes in the fitting procedure relate to OHS situations, where to avoid a potentially hazardous situation it is suggested that protective safety gear be worn or a safe work procedure be employed. If these notes and warnings are not heeded, injury may result.

HAVE AVAILABLE THESE SAFETY ITEMS WHEN FITTING PRODUCT:

Protective eyewear 	Hearing protection 
---	---

FITTING THE ROOF TOP TENT SOLAR PANEL IS UNDERTAKEN IN 5 STAGES:

1. Attaching the solar panel to blade brackets and securing solar panel assembly to rails
2. Red anderson plug template and cable gland drilling.
3. Cable routing of wiring gland installation.
4. Harness trimming and terminal crimping
5. Check and clean up.

Note: It is recommended that 2 people to be used to position and secure Solar Panel Assembly to rails and the Roof Top Tent be in the closed position while doing so off vehicle.

















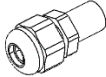



!! IMPORTANT !! other than specifically specified in this instruction

FASTENER TORQUE SETTINGS:

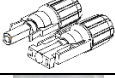

SIZE	Torque Nm	Torque lbft
M6	9Nm	7lbft
M8	22Nm	16lbft

Screw torques must be adhered to avoid warranty issues and should be checked at each vehicle service interval.

THE FITTING KIT CONTAINS:

Kit Number	Part No	Image	Qty	Description
804500 Solar Kit	560PD059		2	BLADE BRACKET - SOLAR PANEL
	560PD074		1	BRACKET - CONNECTOR SOLAR PANEL
	560PD057		1	PLATE - POWER SOCKET
	561AQ058		1	BRACKET ASSEMBLY - POWER SOCKET
	80081245		1	SOLAR PANEL 120W
6178254 Bag mounting kit	559PJ008		1	RED ANDERSON PLUG LEAD
	559PD075		1	PLATE - TEMPLATE POWER SOCKET
	559PH024		1	M12 CABLE GLAND
	559PH025		1	CABLE GLAND NUT
	559PH027		2	CABLE TIE BASE
	180302		5	CABLE TIE 4.8 X 180 MM BLACK
	6609088		18	RIVET OP 3/16 DIA 4.8-11.1
	6151677		4	T BOLT SQUARE HEAD M8x1.25
	4581085		4	WASHER FLAT M8
	6151212		4	NUT HEX NYLOC M8
	559PH026		1	CONNECTORS SOLAR PANEL
	6602018		1	ALCOHOL WIPE
	6151626		1	SCREW PAN HEAD
	559PY002		1	LABEL – "SOLAR ONLY"
	4584329		2	WASHER FLAT M6x12
	6151459		2	BUTTON HEAD SCREW M6x16

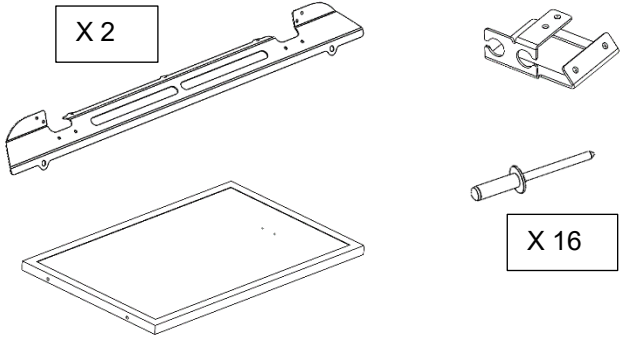
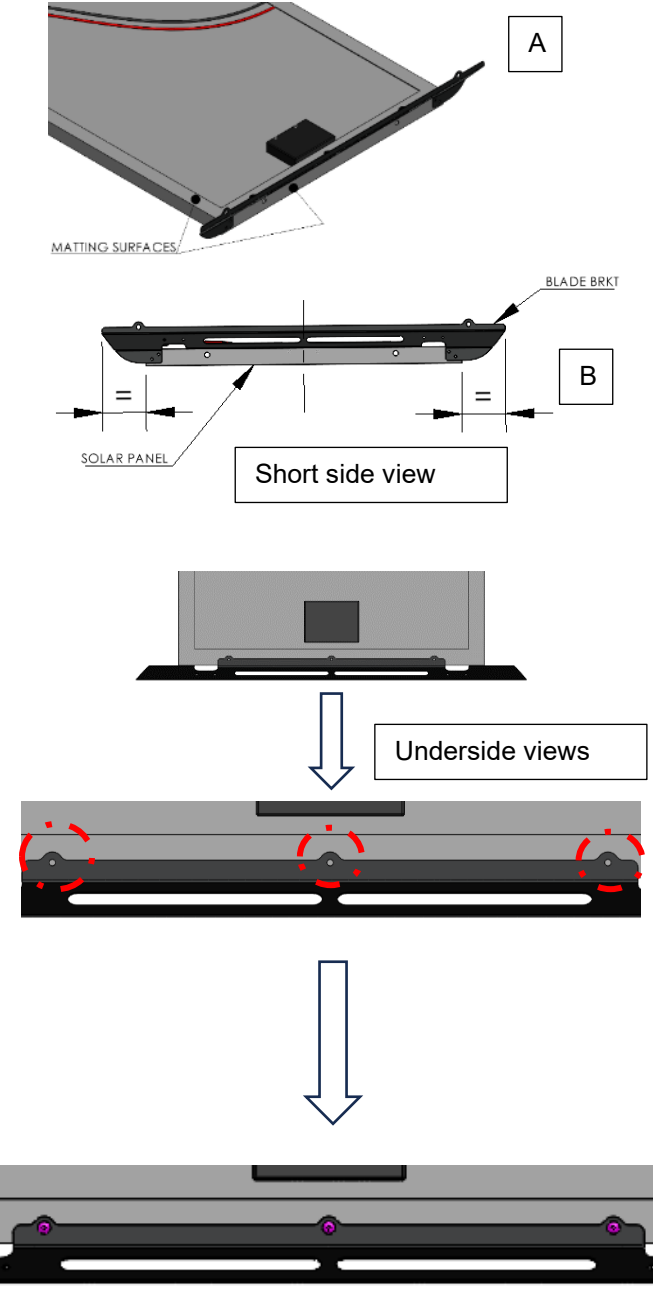
STEP 1: ATTACHING SOLAR PANEL TO SUPPORT BRACKETS AND TENT ROOF BARS

 <p>X 2</p> <p>X 16</p>	<p>1.0) Locate and unwrap blade brackets 560PD059 (2 off), bracket 560PD074, solar panel 80081245 and unpack rivet 6609088 (16 off).</p>
 <p>A</p> <p>B</p> <p>Short side view</p> <p>Underside views</p>	<p>1.1) Lay the solar panel up-side down on a blanket to protect the glass side, so the underside is showing and accessible (A), take a blade bracket and align in centrally (B) to the short side on Solar Panel, ensuring all blade bracket mating surfaces are sitting flush with the surfaces of the Solar Panel.</p> <p>Note: Use G-clamps to hold in place if required.</p> <p>1.2) Use 5.2mm drill bit and battery drill to drill through the three holes in the blade bracket through the aluminium frame wall of the underside of the solar panel as shown.</p>  <p>Note: Ensure blade is in the correct position and sitting flush with mating surfaces of the solar panel before drilling.</p> <p>1.3) Install three rivets, securing the blade to under side of the solar panel</p>  <p>Note: G-Clamps can now be removed</p>

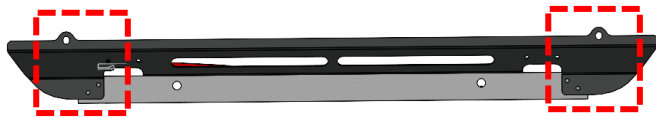

BOTH SIDES

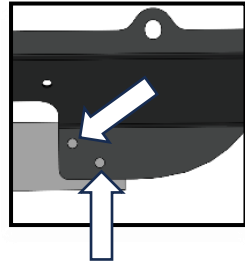

1.4) Now that the Blade is secure to the underside of the solar panel, drill through the side holes on blade bracket using battery drill and 5.2mm drill bit through the frame of the solar panel.



1.5) Rivet in two places per end as shown.



1.6) Repeat the above steps for other side of solar panel with remaining blade bracket.

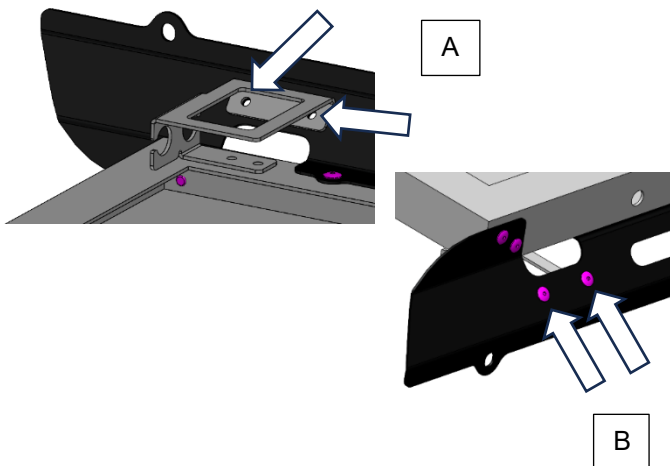
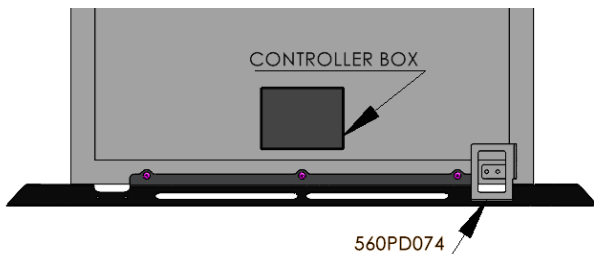

1.7) Take the mount bracket for the solar panel connectors (560PD074) and locate the bracket in position. It must sit on the same side of controller box fixed on the underside of the solar panel. The angled face of the bracket is to go to the inside face of the blade bracket.

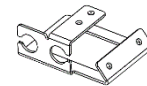

1.8) Align holes (A) and rivet two places from the **outside** of the blade bracket side to secure (B).



Note: The bracket will only fit one way, do not rivet if the bracket is not sitting flush with blade bracket and solar panel's underside frame.

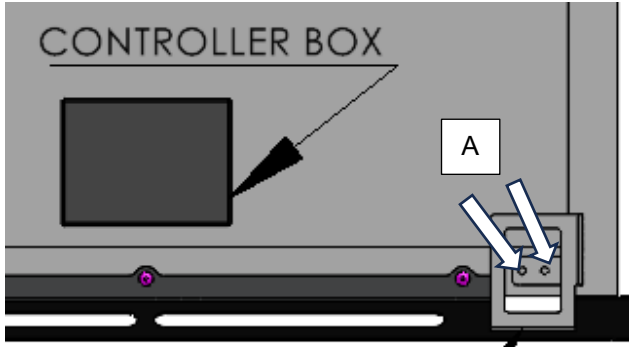

560PD074

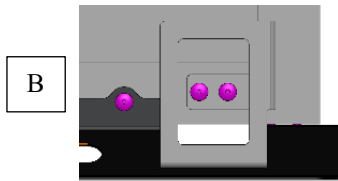

1.9) Place the solar panel assembly back on its top face with underside showing.

1.10) Drill 5.2mm holes in two places (A) and install two rivets (B) to finish securing the bracket.

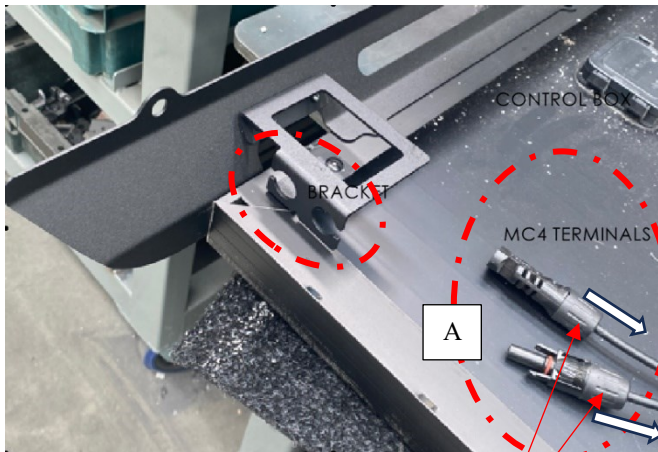

1.11) To assemble the MC4 terminals leads from control box on the solar panel to the bracket (560PD074), first unscrew the end caps on MC4 terminals (A).

Terminal bracket

End caps

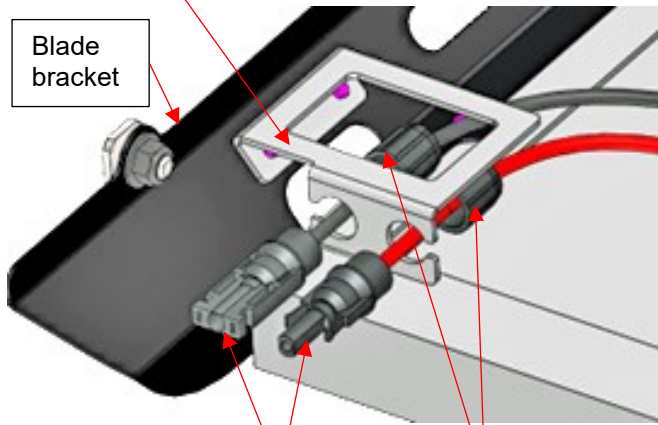



Terminals

End caps

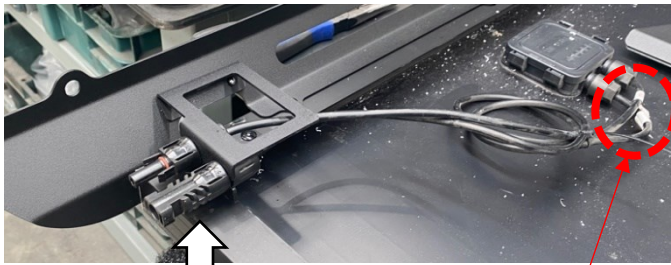
1.12) Pass one terminal between the inside of terminal bracket and the blade bracket and the other to be placed from the outside of the bracket, as shown.



A

6151677		4
4581085		4
6151212		4

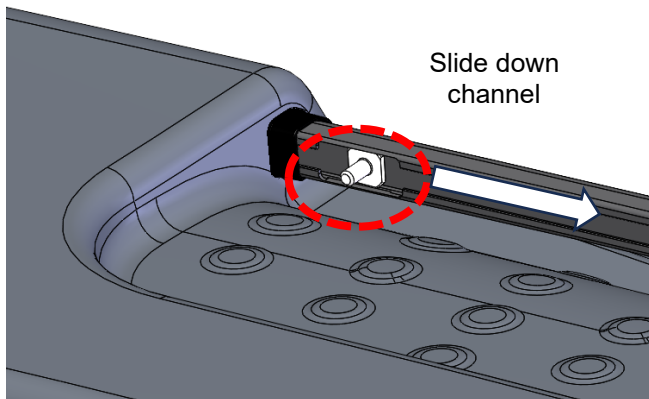

M8 T-Blot

1.13) Secure the terminals into position via re-fastening the ends caps to the bracket. The solar panel assembly is now ready to be mounted to Altitude Roof Top Tent's Roof rails.

Note: Check and take note to which terminal is Positive (+), confirm by tracing polarity tags (A) to terminal, terminal with red O-ring (Male Plug) is usually Positive (+).

1.14) Locate T-bolts, M8 flat washers and M8 nyloc nut, four of each.

1.15) Slide the four T-bolts into roof rail channels via access slots located at each end of the tent roof rails and then position T-bolts to approximate 700mm apart from each other, mirroring positions for other side.

1.16) Take the solar panel assembled with the blade brackets and position it so the terminals on the solar panel are facing rearward and located on the right-hand side of the tent. Place the side with the terminals onto the T-bolt Studs first as shown.

Note: For ease of fitment, two person operation is recommended, (one each side).

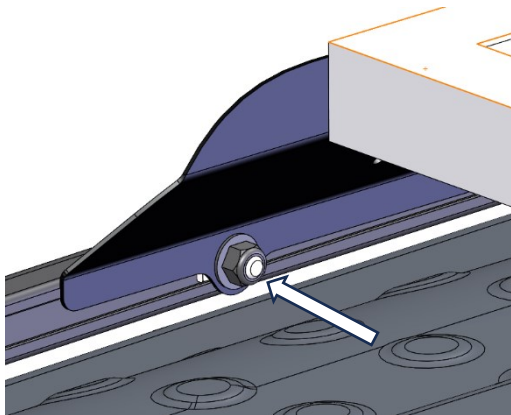

1.17) Lower left-hand side of solar panel assembly and flex the blade bracket inboard (10mm approx.) so that is able to fit over the corresponding M8 T-bolt as shown at both ends.

1.18) Loosely fit M8 washer and M8 Nyloc in the four fastening positions on roof rail M8 T-bolts as shown. **Do not tighten yet.**

STEP 2: RED ANDERSON PLUG TEMPLATE AND CABLE GLAND DRILLING.



559PJ008



559PD075



560PD057

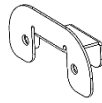

560PD058

2.0) Locate wiring harness, drilling template and anderson plug mounting brackets.

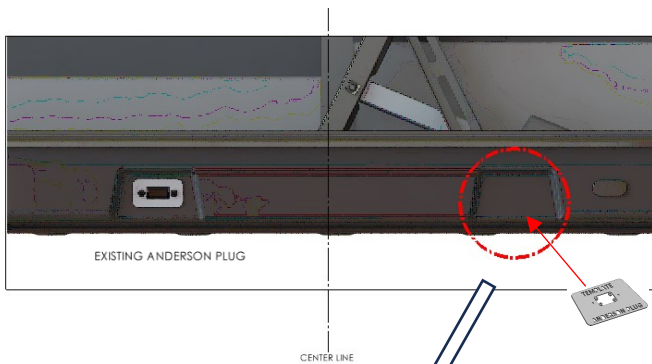

2.1) Place anderson plug template at rear of tent on the right-hand side, directly opposite existing anderson plug.

2.2) Position and fix template (559PD075) central to depression.

2.3) With 3mm drill bit, drill the 2 holes through the template and lower shell and then at each of the four corners of the square in the template, to create six holes (A) through the tent's lower shell.

Note: To prevent potential damage when transferring holes, place shielding (wooden sheet or similar) between inner lower shell and actuator mechanism (B).



A

6 PLACES

Shielding



B

2.4) Remove drilling the template and open-up all six newly drilled holes to 8mm.

2.5) Mark horizontal and vertical lines connecting the inner four inner holes as shown.



8mm. Dia.
6 places

Marked
lines

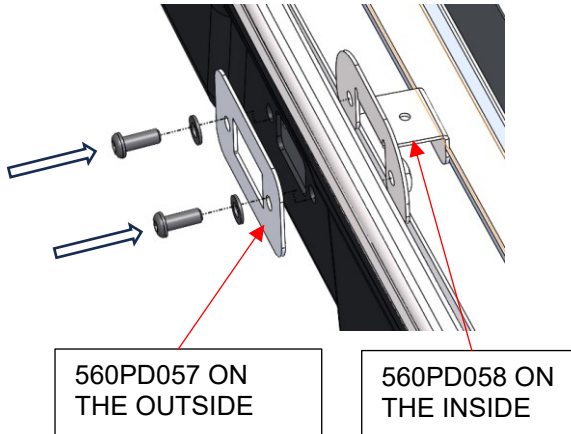

560PD057 ON THE OUTSIDE

560PD058 ON THE INSIDE

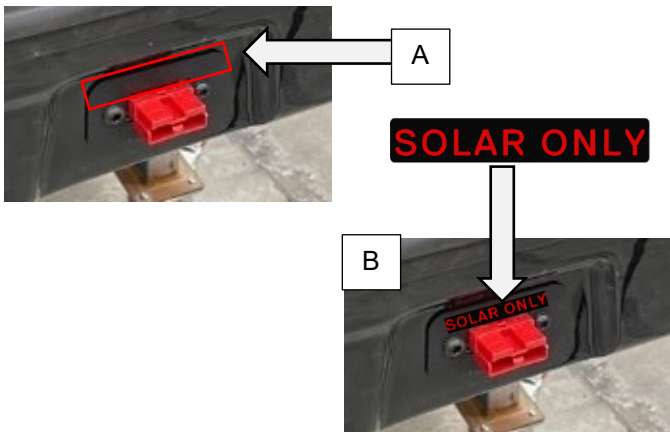
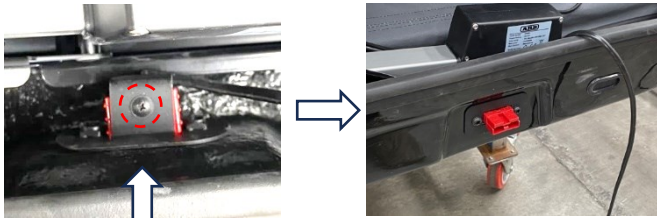

2.6) Use a “Jab/Dry Wall” hand saw and a metal file to remove the square inner section, to create a hole suitable for the anderson plug loom red connector (on 559PJ008).



2.7) Take the anderson plug mounting brackets and fit the M6 button head screws (6151459) with M6 washers (4584329) provided, in two places.

Tighten screws to specified torque



2.8) Take the red plug end of wiring harness and pass it through square hole in tent shell base and secure the red anderson plug with screw 6151626, as shown to the bracket.

NOTE: Harness routing is to occur at a later step.

2.9) Take the alcohol wipe and clean the lower shell face in area indicated (A) above the plug, allow to dry and apply “Solar Only” sticker central in place as shown (B).

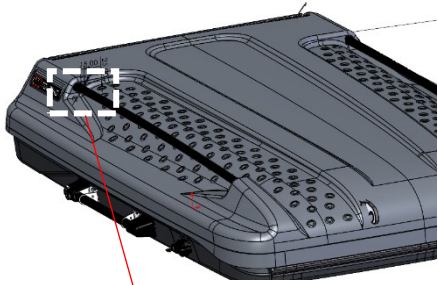

A

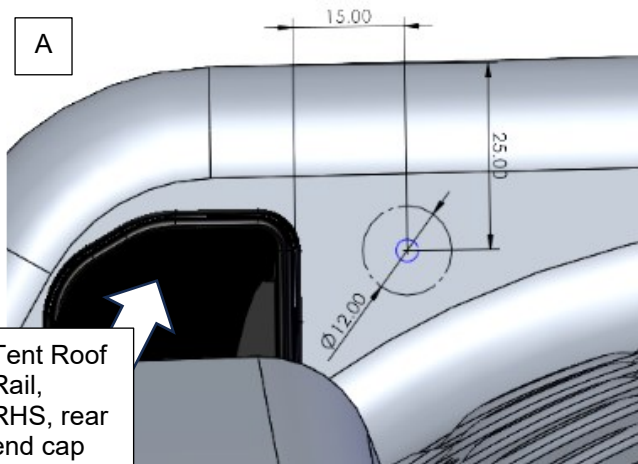

Tent Roof Rail,
RHS, rear
end cap



2.10) With a step drill or hole saw, drill 12mm diameter hole in location indicated (A) which is measured off the rear rubber fitting on the tent's roof rail on the **right hand side**. Hole centre is located 15mm horizontally and 25mm down from the top of the shell

Note: Take note of tent orientation and where 12mm hole is to be drilled. Same side to Solar Anderson plug and to the rear as indicated.

2.11) Deburr and clean any surrounding debris around the hole, ready for cable routing and cable gland installation.

STEP 3: CABLE ROUTING AND CABLE GLAND INSTALLATION.



- 3.0) Go to the rear of the tent and pass the end of the harness through rear access flap (A) in the canvas lower end corner into the interior behind the interior pocket.

NOTE: Open tent fully to ensure routing is correct length once installed.

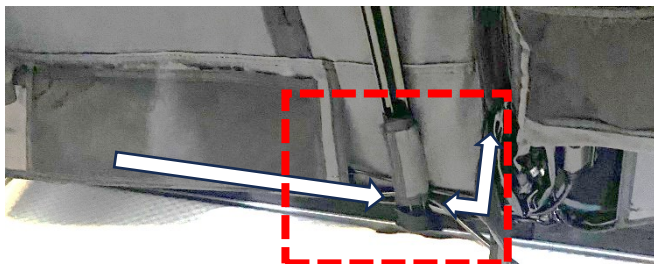

- 3.1) Find the existing cable routing for the tent and run the new harness along the same route, paying close attention in following the exact route taken by existing cable routing.

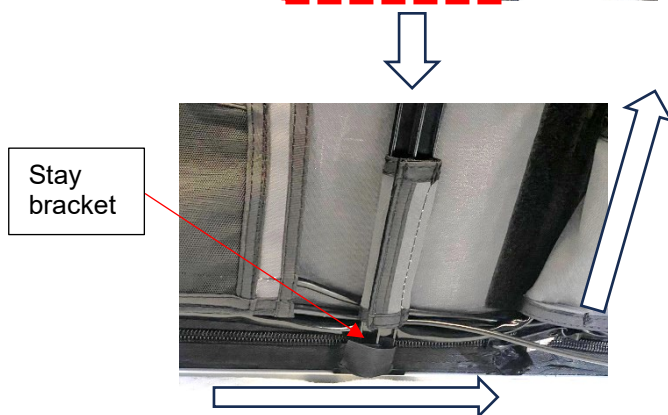

- 3.2) On the inside of the canvas unsecure the velcro capturing the existing harnesses and ensure the new harness runs behind the stay bracket against the canvas. Begin then to run the harness vertically following the existing tent wiring.

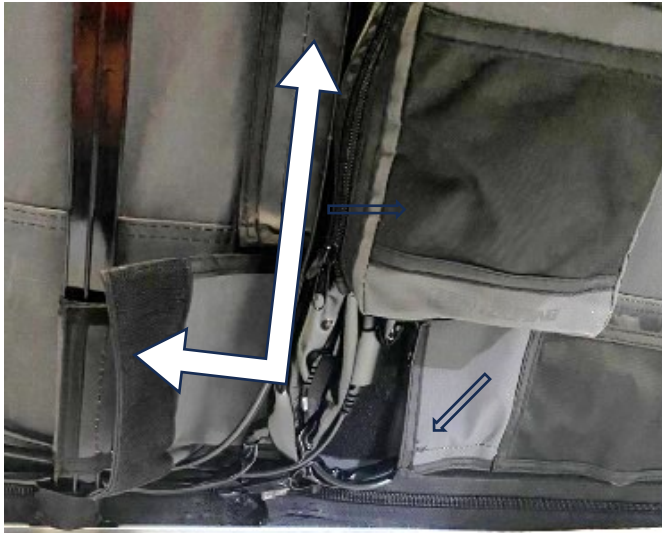

3.3) Run the harness now vertically to the roof of the tent behind the velcro flap.



3.4) Resecure all Velcro retaining the new and existing cable routing and run the wiring harness to the outside rear of the tent.



Rear hatch

Pass through

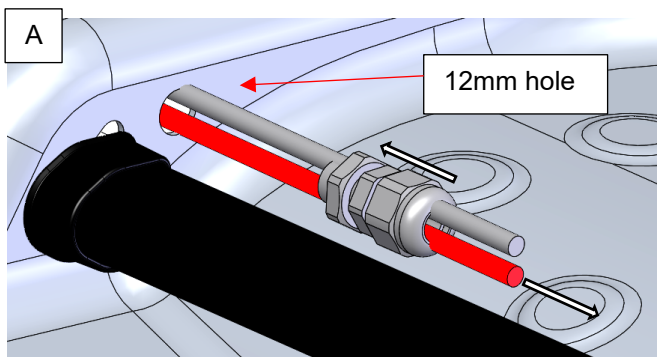

A

12mm hole

M12 CABLE GLAND NUT
TENT ROOF CAVITY

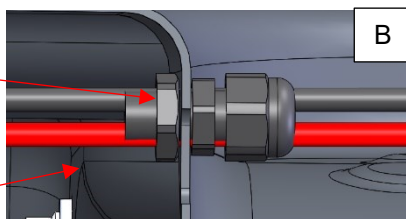

B

3.5) You should now see the cable running outside the rear of the tent at top, open up rear hatch.

3.6) Take the end of the harness cable and run it into the roof cavity of the tent. Feed cable to the side at an angle so it feeds towards the right rear hand side of the roof cavity. Keep feeding it through until you see the end appear in the roof cavity on the right-hand side rear corner via inside the rear hatch.

3.7) Pull cable harness through until taught.

3.8) Locate cable gland and M12 cable gland nut provided in kit. Pass the nut through cable as shown.



559PH024 Cable Gland	559PH025 M12 nut
-------------------------	---------------------

3.9) Then pass cable through 12mm hole that was previously drilled next to the tent roof rail from inside the roof cavity via the hatch (A) and then feed cable gland onto the wiring harness and fasten with M12 cable gland nut (B). Pull harness all the way through and tighten cable gland around cable to ensure a tight seal.

NOTE: Ensure cable is sitting in a relaxed state inside the rear hatch, cable should have some play and be able to move freely

STEP 4: TRIMMING HARNESS & MC4 TERMINALS CRIMPING

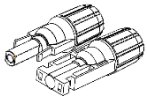

55PH026
(MC4 connectors)



- 4.0) Retrieve the solar panel connectors (55PH026) from the kit and ready wire crimpers and side cutters for installation.

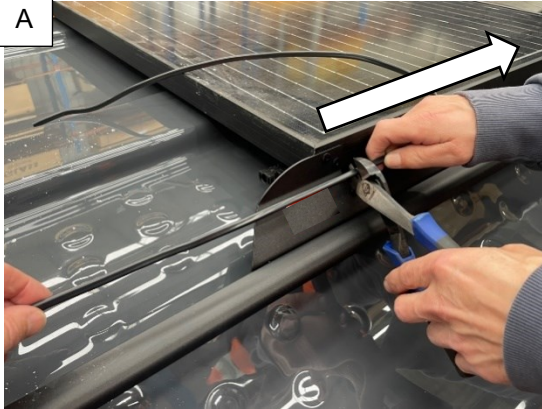

10.mm

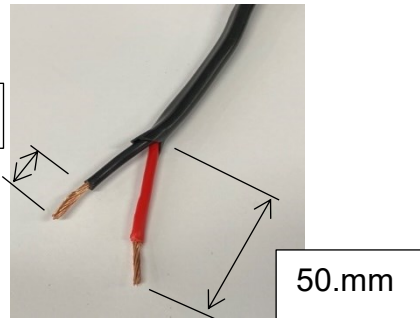

50.mm

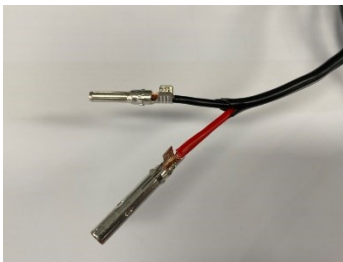

Housing

Terminal pins

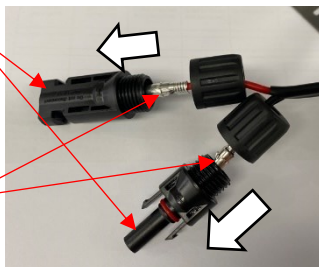

- 4.1) Slide solar panel assembly into its most forward position along the roof rails (A).

- 4.2) Extend the harness along the direction of the roof rails and trim with side cutters at vertical rivet point as show on at the side of the blade bracket.

- 4.3) Strip back the sheathed wires for outside sheath 50.mm and bare the ends of the wires to 10.mm.

- 4.4) Crimp two terminal pins onto the wires.

Note: Check polarity on solar panel assembly to ensure Crimp terminal and plug corresponds

- 4.5) Slide connector parts in place and push terminal pins into position until they clip into the connector housing.

- 4.6) Screw ends on until tight as shown.

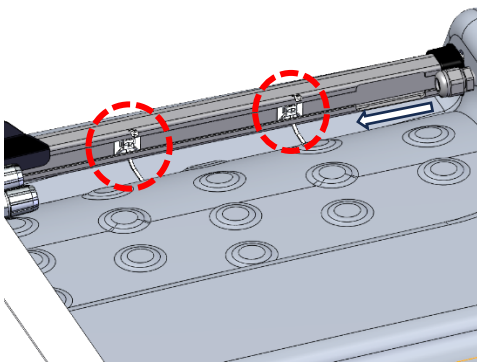
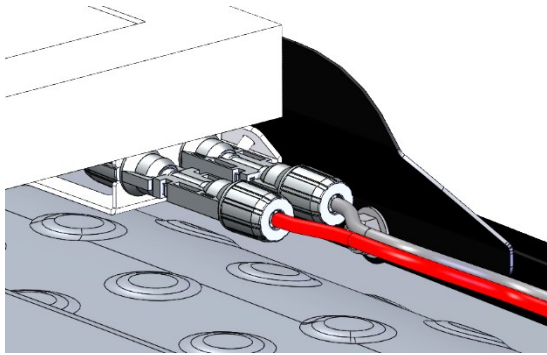
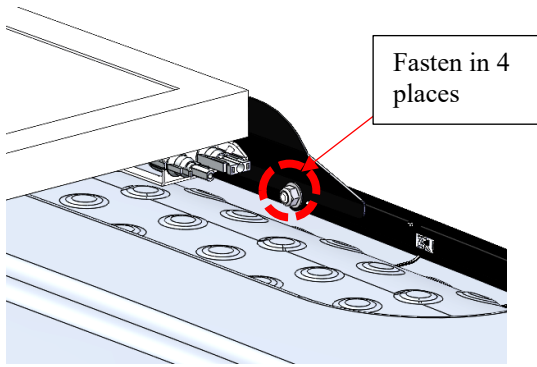

4.7) Slide and re-centre the solar panel assembly on the roof rails and secure in place via four M8 nyloc nuts.

Fasten nuts to specified torque



Torque M8 to 22Nm

4.8) Plug in the corresponding connectors on solar panel assembly ensuring polarity is correct.

4.9) Locate the two cable tie bases (559PH027) and cable ties provided with kit. Thread a cable tie into each on the cable tie bases and slide the cable tie bases in position along the roof rail via slot at the end of rail as shown.

4.10) Secure the wiring harness to the cable ties along the side of the roof rail.



4.11) Take the remaining three cable ties and retain harness in these areas,
(A) – Scissor mounting bracket



(B) – At pass through into the roof cavity on the outside top shell of the tent location.

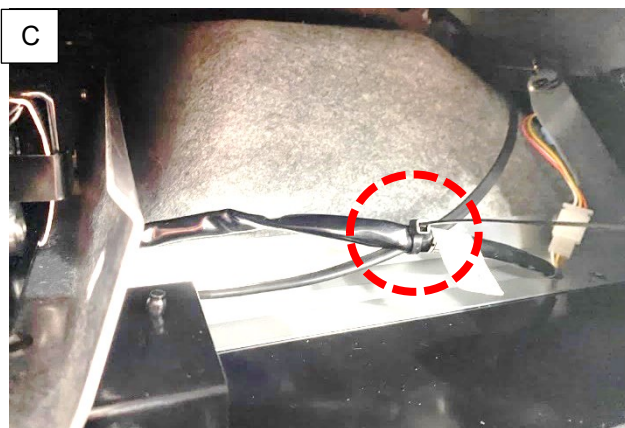

(C) - In roof cavity via the rear hatch, cabling it to an existing harness.

STEP 5: CHECK AND CLEAN UP

- 5.0) Check Torques of all bolts are completed as in mentioned in these instructions.
- 5.1) **Make sure to cycle tent Open and Close.** To ensure cabling is secured.
- 5.2) Close the Roof Top Tent make sure to close and key lock the handles.
- 5.3) **Place a copy of these fitting instructions in the vehicle owner's manual.**
- 5.4) **If available and fitted to the vehicle, test the system as connected to the customer's solar charging system and operation via a multimeter.**

IT IS IMPORTANT THESE INSTRUCTIONS ARE GIVEN TO THE CUSTOMER AS IT CONTAINS IMPORTANT SAFETY INFORMATION AND ADVICE.