



FITTING INSTRUCTIONS

Part Number: **3452040**
Product **SUMMIT COMBAR SUIT RAM 1500 MY19 AF20 8-10**
Description:
Suited to **RAM 1500 2019 (LARAMIE & EXPRESS; AUSTRALIAN RH DRIVE**
vehicle/s: **CONVERSION)**
Optional Kits:
3500520 – ARB LED FOG LIGHT LOOM (NON-FACTORY FOG LIGHT
VEHICLES)
3500910 – ARB LED FOG LIGHT KIT – LRG (3500520)
3500680 – FOG LAMP HOUSING CLEAR LENS KIT
3501000 – SUMMIT BAR WINCH INSTALL KIT

WARNING

REGARDING VEHICLES EQUIPPED WITH SRS AIRBAG:

When installed in accordance with these instructions, the front protection bar does not affect operation of the SRS airbag.

ALSO, NOTE THE FOLLOWING:

- ◆ This product must be installed exactly as per these instructions using only the hardware supplied.
- ◆ In the event of damage to any bull bar component, contact your nearest authorised ARB stockist. Repairs or modifications to the impact absorption system must not be attempted.
- ◆ Do not use this product for any vehicle make or model, other than those specified by ARB.
- ◆ Do not remove labels from this bull bar.
- ◆ This product or its fixing must not be modified in any way.
- ◆ The installation of this product may require the use of specialized tools and/or techniques
- ◆ It is recommended that this product is only installed by trained personnel
- ◆ These instructions are correct as at the publication date. ARB Corporation Ltd. cannot be held responsible for the impact of any changes subsequently made by the vehicle manufacturer
- ◆ During installation, it is the duty of the installer to check correct operation/clearances of all components
- ◆ Work safely at all times
- ◆ Unless otherwise instructed, tighten fasteners to specified torque

ARB 4x4 ACCESSORIES

Corporate Head Office

42-44 Garden St
Kilsyth, Victoria
AUSTRALIA 3137

Tel: +61 (3) 9761 6622
Fax: +61 (3) 9761 6807

Australian enquiries
North & South American enquiries
Other international enquiries

sales@arb.com.au
sales@arbusa.com
exports@arb.com.au

www.arb.com.au

GENERAL CARE AND MAINTENANCE

By choosing an ARB Bar, you have bought a product that is one of the most sought after 4WD products in the world. Your bar is a properly engineered, reliable, quality accessory that represents excellent value. To keep your bar in original condition it is important to care and maintain it following these recommendations:



- Prior to exposure to the weather your bar should be treated to a Carnauba based polish on all exposed surfaces. It is recommended that this is performed on a six monthly basis or following exposure to salt, mud, sand or other contaminants.
- As part of any Pre Trip Preparation, or on an annual basis, it is recommended that a thorough visual inspection of the bar is carried out, making sure that all bolts and other components are torqued to the correct specification. Also check that all wiring sheaths, connectors, and fittings are free of damage. Replace any components as necessary. This service can be performed by your local authorized ARB Stockist.

FITTING REQUIREMENTS

REQUIRED TOOLS FOR FITMENT OF PRODUCT:

Metric socket and spanner set 8-25mm range	External Circlip pliers
Screwdrivers; Philips and Flat blade	Jigsaw or Multi-Tool with blade for plastic cutting
Short Body Power Drill 13mm (1/2") capacity	Dia. 10.0mm drill bit
Torque Wrench (9-120Nm)	Marking pen
Brake line clamp	Soft Hammer
Metric hex & torx key set	Loctite© 262 or equiv.
Wide masking tape	Stanley knife
Small Spirit Level	Tape Measure & 2 x 300mm rulers
Right-angled Power Drill 13mm capacity	Paint black fast drying
Smooth Flat & Round Files	Low Tack Film (To protect Bull Bar / Vehicle)

HAVE AVAILABLE THESE SAFETY ITEMS WHEN FITTING PRODUCT:

Protective eyewear		Hearing protection	
--------------------	---	--------------------	---

NOTE: 'WARNING' notes in the fitting procedure relate to OHS situations, where to avoid a potentially hazardous situation it is suggested that protective safety gear be worn or a safe work procedure be employed. If these notes and warnings are not heeded, injury may result.

FASTENER TORQUE SETTINGS:

SIZE	Torque Nm	Torque lbft
M6	9Nm	7lbft
M8	22Nm	16lbft
M10	44Nm	32lbft
M12x1.25 PC 8.8	80Nm	60lbft
M12x1.5 PC 10.9	92Nm	68lbft

PARTS LISTING

APPLICATION.	PART NO.	QTY	DESCRIPTION
Mount Brackets to Chassis	3752725R	1	BRKT MNT ASY RH SUIT DR1500 19
	3752725L	1	BRKT MNT ASY LH SUIT DR1500 19
	3752890R	1	BKT CHASS BRC IN R SUIT DR1500
	3752890L	1	BKT CHASS BRC IN L SUIT DR1500
	3752891R	1	ASY BKT CH BR OUT R SUIT R1500
	3752891L	1	ASY BKT CH BR OUT L SUIT R1500
	6151545	6	BOLT HXHD FL M12x1.25x35 PC8.8 BTZP
	6151480	6	NUT FLANGE M12 X 1.25 PC8 TZP
	6151542	2	SCREW SEMS M10x1.5x40 PC8.8 TZP
	4721974	4	TUBE CHASSIS CRUSH SUIT DR1500
	6151508	4	BOLT HXHD M10x1.5x90 PC8.8 TZP
	4584361	4	WASHER M10x25x4 HV300 TZP480
	6151321	2	NUT FLANGE M10x1.5 PC8 TZP
	6151986	2	BOLT HX M12x1.5x50 PC10.9 PT30 BTZP
	6253337	2	SPACER M12 OD29 x ID12.5 x 12 TZP
Fit Lights and Mouldings	3500880	1	GRILLE SPLIT PAN KIT
	5100200	1	BUFF KIT 2PCE FRONT SECTION (SET)
	5100210	1	BUFFER TOP SECTION UPRIGHT (SET)
	6821287	1	LAMP LED INDICATOR (SET)
	3163082	1	KIT SURROUND ARB FOGLIGHT (SET)
	6821116	4	GROMMET NYLON SNAP IN TYPE
5848428	6	SHIM OVER RIDER 1.6MM TZP	
FPA Sensors or Plugs to Bull Bar	3193905	6	PLATE SENSOR MOUNT DR1500
	4584295	12	WASHER FLAT M6 x 12 x 1.3 BTZP
	6151223	12	NUT HX NYLOC M6x1.0 BTZP
	3163254	6	PLUG BLANKING BLACK 34.9mm
	6821356	3	FPA EXTENSION HARNESS KIT
Number Plate to Bull Bar	6821189	2	GROMMET RND FC 1500 080 090
	6151384	2	SCREW ST PHDCOL PH 5.2 X 16
	6151550	3	BOLT HXHD M6 x 1.0 x 25 PC8.8 BTZP
	3759488	1	BRACKET LIC PLATE FIXED LARGE RAD
	4584295	3	WASHER FLAT M6 x 12 x 1.3 BTZP
	6151128	3	NUT FLANGE M6 x 1.0 TZP
Bull Bar to Mount Bracket Assy	6151545	6	BOLT HXHD FL M12x1.25x35 PC8.8 BTZP
	6151480	6	NUT FLANGE M12 X 1.25 PC8 TZP
	6253336	6	SPACER HORZ ADJ SUIT DR1500 19
	6151550	4	BOLT HXHD M6 x 1.0 x 25 PC8.8 BTZP
	6151128	4	NUT FLANGE M6 x 1.0 TZP
	6151542	4	SCREW SEMS M10x1.5x40 PC8.8 TZP
	6151321	4	NUT FLANGE M10x1.5 PC8 TZP
Fit Winch Cover Panel	6523379	1	PANEL WINCH CVR BK SUIT DR1500
	6151550	4	BOLT HXHD M6 x 1.0 x 25 PC8.8 BTZP
	4584295	8	WASHER FLAT M6 x 12 x 1.3 BTZP
	6151223	4	NUT HX NYLOC M6x1.0 BTZP
Brace to Bull Bar	4681726	1	BRACE CROSS SUIT DR1500 19
	6151555	7	SCREW SEMS M10x1.5x30 PC8.8 BTZP
	6151321	7	NUT FLANGE M10 x 1.5 PC8 TZP
Stone Tray to Bull Bar	6523377	1	PANEL STONE GRD SUIT DR1500 19
	6151300	4	NUT CAGED M6 2.6-3.5 TZP
	6151550	4	BOLT HXHD M6 x 1.0 x 25 PC8.8 BTZP
	4581082	4	WASHER FLAT M6 x 19 x 1.6 BTZP
	6151546	2	BOLT HXHD M8 x 1.25 x 25 PC8.8 BTZP
	4581303	2	WASHER FLAT M8 x 26 x 2.8 BTZP
	6151132	2	NUT FLANGE M8 x 1.25 PC8 TZP
Wing Under Panels	6523378R	1	WING UPANEL RH SUITS DR1500 19
	6523378L	1	WING UPANEL LH SUITS DR1500 19
	6151526	10	NUT CAGED M6 1.8-2.7x9.5 480BLK
	6151550	10	BOLT HXHD M6 x 1.0 x 25 PC8.8 BTZP
	4581082	10	WASHER FLAT M6 x 19 x 1.6 BTZP
	3752730	2	BRKT WING PANEL SUIT DR1500 19
	6151546	4	BOLT HXHD M8 x 1.25 x 25 PC8.8 BTZP
	4581303	4	WASHER FLAT M8 x 26 x 2.8 BTZP
	6151132	4	NUT FLANGE M8 x 1.25 PC8 TZP

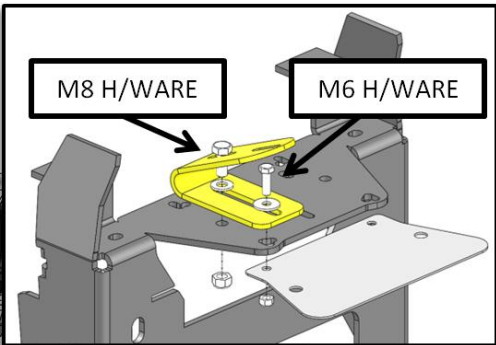
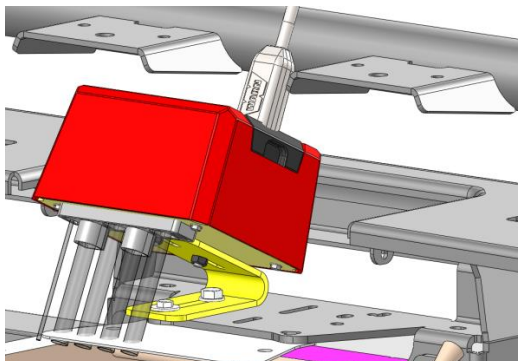
Miscellaneous	6151349	2	SCREW ST PHD 8Gx15x15 TZP
	6191028	1	TRIM PINCH WELD 1400mm
	3781945	1	TEMP BMPR CUT 3452040 DR1500
	180302	6	CABLE TIES
	3781940	1	F/INST 3452040 SUIT DR1500 19
OPTIONAL WINCH FITMENT:	3756499	1	BRKT CONTROL BOX MNT MULTIFIT
Use these items that are included in this kit if fitting a Warn Solid State Control Box to Bar (ie as per Warn XD, 9.5XP, M12 series winches...).	6151021	1	BOLT HXHD M8x1.25x20 PC8.8 ZP
	4584336	1	WASHER FLAT M8x17x1.6 TZP
	6151032	1	NUT HEX NYLOC M8x1.25 TZP
	6151180	1	BOLT HXHD M6x1.0x20 PC8.8 TZP
	4581072	1	WASHER FLAT M6x20x1.6 TZP
	6151162	1	NUT HEX NYLOC M6x1.0 TZP480
			

FITTING PROCEDURE



1. Remove number plate and screws. Retain all items. (NB: Laramie model shown in most photos)



2. Disconnect all electrical and wiring looms located behind the bumper on the LHS including Driving Lights, Indicator Lights and FPA Sensor loom (If present).

FPA Sensor loom - disconnected





3. If equipped, remove 2x OE tow hooks, 2x M12 bolts and 4x M12 nuts using an 18mm deep socket and discard (If present).

Items discarded:



4. Remove 2x upper bumper M12 retaining nuts (*taking care to support the bumper*) using an A/F 18mm deep socket and wrench. Discard the nuts.



BUMPER – REAR VIEW



5. For Laramie vehicles, remove lower chrome bumper from vehicle and place face down on a soft non-marking surface.

6. **For vehicles with FPA Sensors:**

Record the unique location of each sensor and housing combination. For example; using a white paint pen, use "dot patterns" to mark the back of each housing / sensor set from the RHS 1x dot through to the LHS 6x dots, as shown below;

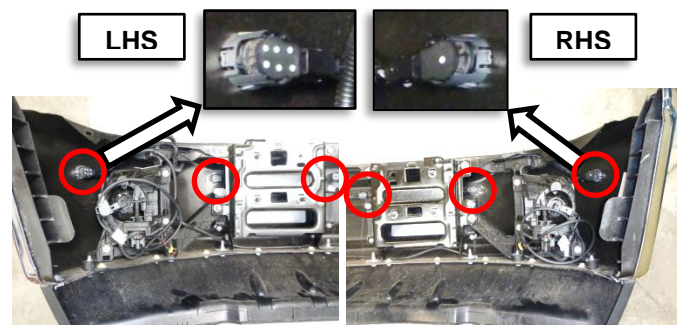

RHS – REAR BUMPER VIEW

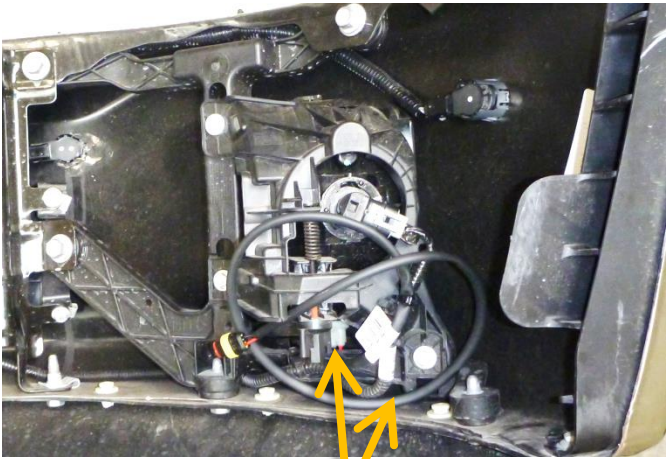

CLEARANCE LIGHT & LOOM

Indicator Loom Wiring: RHS shown, LHS Opposite

7. Vehicles that have been homologated for use in Australia have been fitted with additional clearance lights inside the base of the fog lamps in the bumper.
8. Remove the light and loom from the OE fog lamp as these will be used to connect the 6821287 ARB LED and indicator clearance lamps included in the kit.

CLEARANCE LIGHT LOOM – REMOVED



CUT CLEARANCE LIGHT LOOM HERE



9. Strip back the black outer sheath at the connector end by approximately 100mm
10. Cut through both black and red wires at approximately 70mm from connector end.
11. Discard lamp end.

ENDS RETAINED (x2)

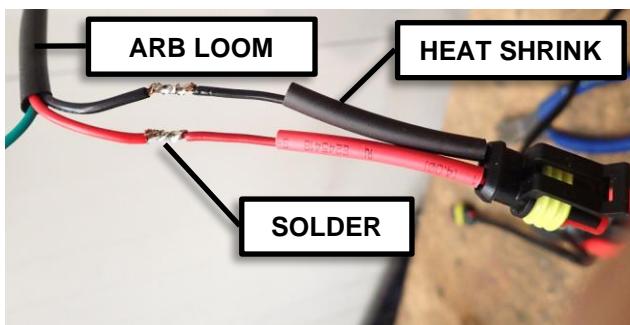

12. Unpack both 3 core looms from the ARB indicator kit 6821287.
13. Using wire strippers and solder, join the red and black wires on the ARB loom to the corresponding red and black wires on the trimmed loom retained above and check electrical continuity.

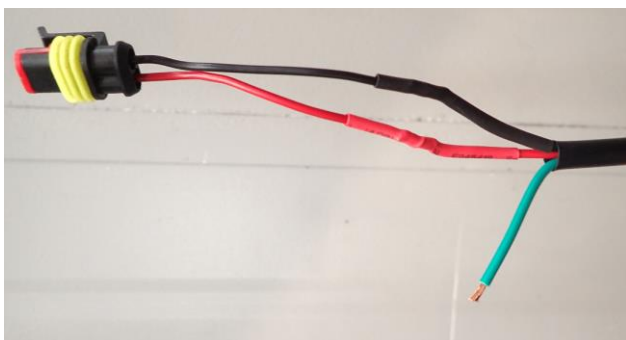

14. Once sturdy electrical connections have been made, insulate the joints with heat shrink or electrical tape.



15. The access point in the wheel arch liner must be opened. Gently remove the lower scrivet to gain access as shown.
16. In order to ensure adequate access to the vehicle's lighting looms, loosen the M6 screw several turns to enable removal of the black earth wire shown.
17. Repeat for opposite side of vehicle.

LOOSEN M6 EARTH WIRE SCREW



LARAMIE



EXPRESS

18. Disengage the large connector from the base of both headlights and gently pull them down below the headlight clusters.
19. Power supply for the ARB LED indicator can be taken from this plug on both sides of the vehicle as shown below;

LARAMIE: PIN12

EXPRESS: PIN3

RHS: Has a White wire with Brown trace

LHS: Has a White wire with Green trace

LARAMIE IDENTIFYING PIN 12 (RHS SHOWN)



EXPRESS IDENTIFYING PIN 3 (LHS SHOWN)

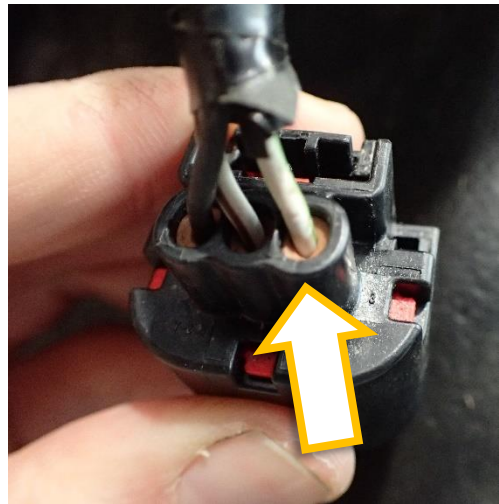

CLEARANCE LOOM CONNECTOR

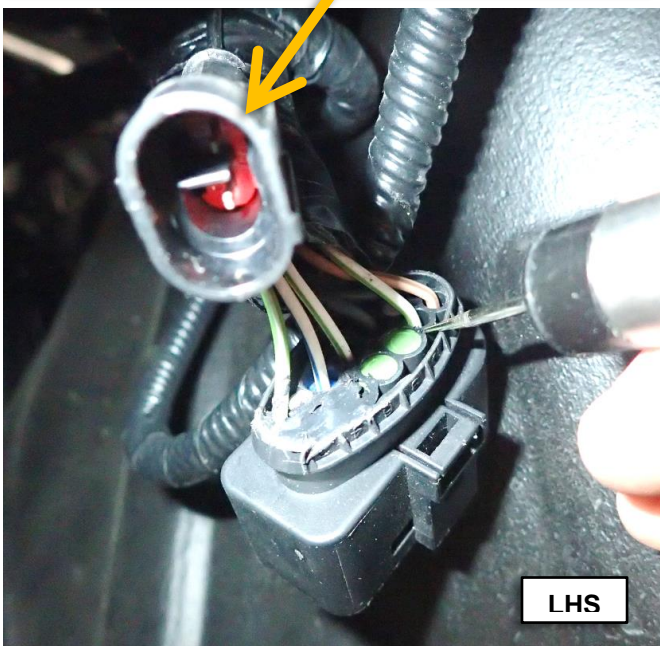

20. Using wire strippers and solder join the green indicator wire on the ARB LED Indicator loom to the corresponding wires described above.
21. Once sturdy electrical connections have been made, reconnect the clearance loom connector to the vehicle and insulate with heat shrink or electrical tape.
22. Reconnect each plug into the headlamp cluster and secure the earth lead back under the M6 screw loosened in Step 16.
23. Repeat for each side of vehicle.

24. Disconnect, remove and retain all sensors, sensor housings, silicone sleeves and remaining OE Lamp and Sensor looms from bumper if present.
25. Discard bumper (LARAMIE) and OE fog lamps.

ITEMS DISCARDED;

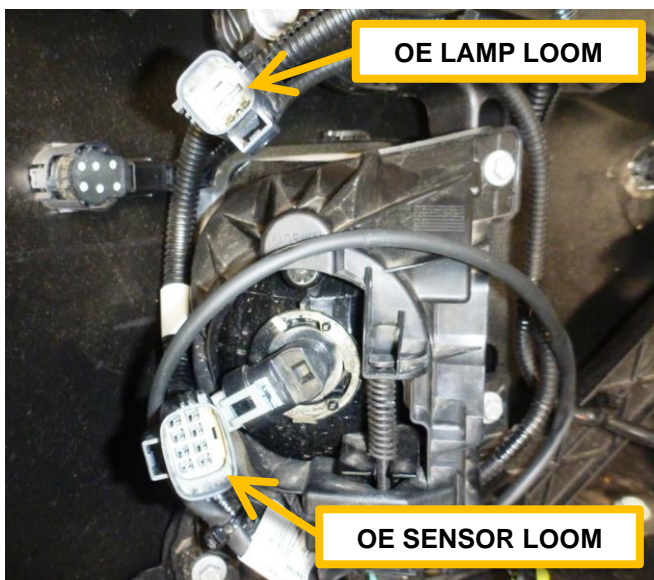



3781945: Trim Template

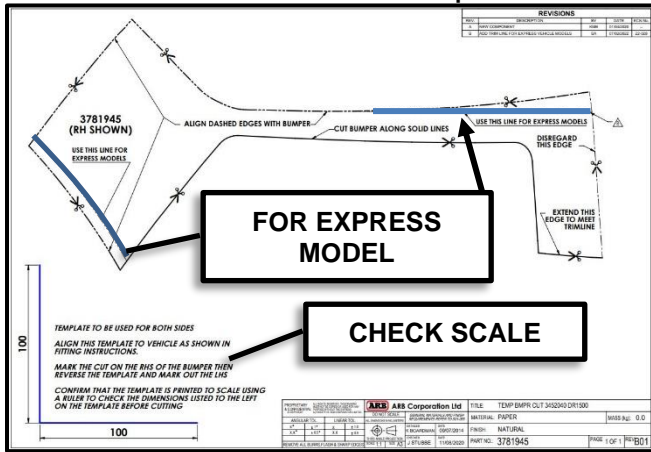

CRITICAL: Upper bumper trim (on vehicle)

26. Carefully cut out the trim template shown at left ensuring that the template is to scale by first measuring the two axes which should be 100mm long each. (NB: RHS template shown, reverse for use on LHS)

CRITICAL: See alternate cutting line on template for Express Models.

LARAMIE

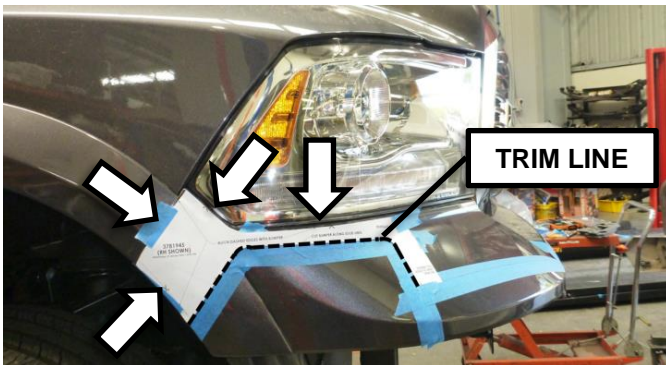

27. On RHS: carefully position trim template prepared in Step 26 by aligning with features on bumper as indicated.

28. Apply non-marking tape along "dotted" trim line areas, then proceed to mark out.

EXPRESS



EXPRESS



"FEATURE LINE 1"

"FEATURE LINE 2"

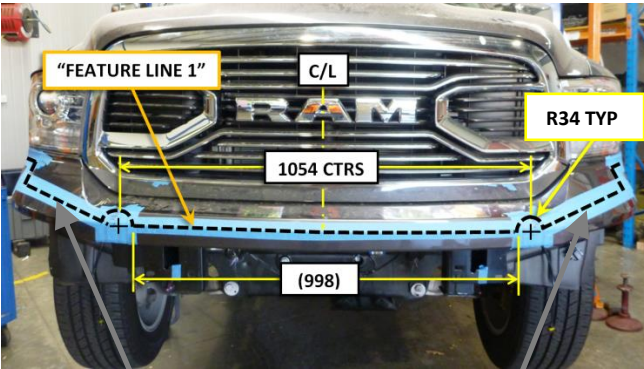
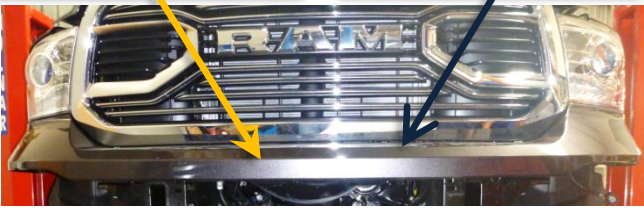

CONNECTING LINES

- 29. Carefully remove template from RHS. Use in reverse to tape and mark out LHS.
- 30. Tape and mark out long dashed lines shown at left following the "feature line 1" at front of bumper and connecting to RHS and LHS trim template profiles as shown at left. Use the logo on the grille to obtain centre line reference.
- 31. Carefully use a multi-tool to trim bumper along "dotted" lines shown at left



Warning: Cutting operations can result in flying debris. Safety equipment should be worn.



- 32. For Express models, remove and discard the lower section of the cut bumper and impact absorber structure.



SECURE BUMPER WITH 2x SCREWS

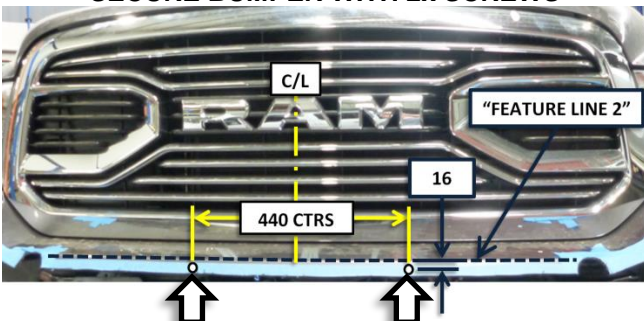

- Secondary trimming of the bumper support moulding is required to clear wings/uprights.
- 33. Mark out and remove the sections of the moulding that sit exposed directly behind the trimmed bumper, preserving the RHS/LHS mount screws as shown below.

BEFORE (RHS SHOWN): AFTER (RHS SHOWN):

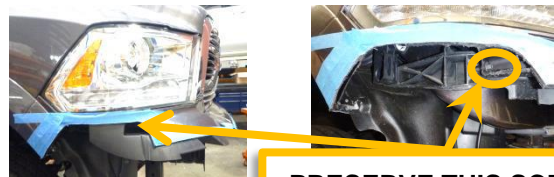

PRESERVE THIS SCREW

- 34. Secure bumper to support moulding with 2x screws ST PHD 8Gx15 TZP as shown at left



Warning: Cutting operations can result in flying debris. Safety equipment should be worn.

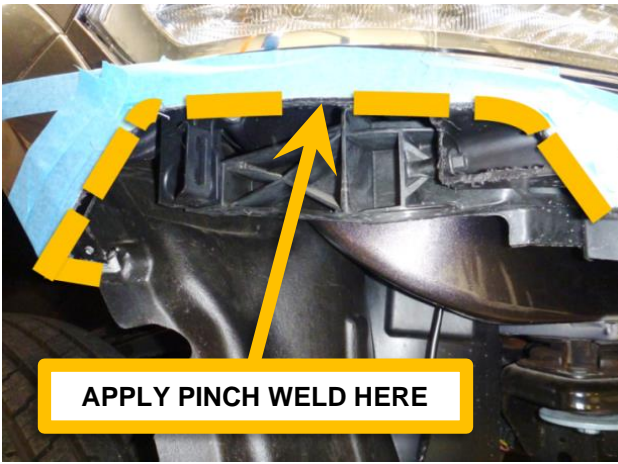

35. Use a file or sandpaper to de-bur all cut edges.
36. Apply a strip of continuous pinch weld to the outermost sides of the trimmed bumper and return inside the wheel arch area. RHS shown LHS opposite

TOP VIEW

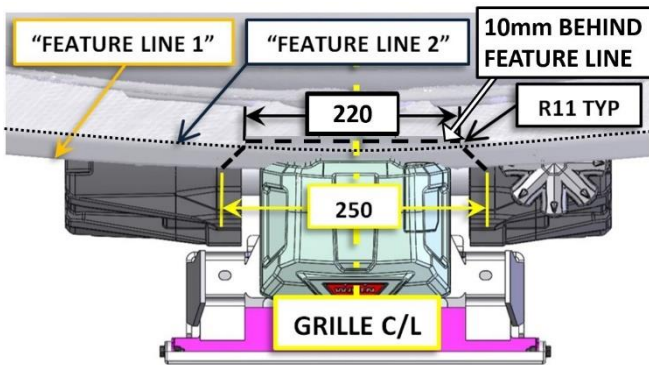

WINCH / CONTROL BOX BUMPER TRIMS:

37. **ALL OTHER WINCHES** (Warn EVO shown): Tape and mark out dashed lines shown at left following "feature line 2" and terminating on "feature line 1" then carefully use a multi-tool to trim bumper along dashed lines, removing centre section indicated.
38. Apply pinch weld to trimmed area.



Warning: Cutting operations can result in flying debris. Safety equipment should be worn.

TOP VIEW

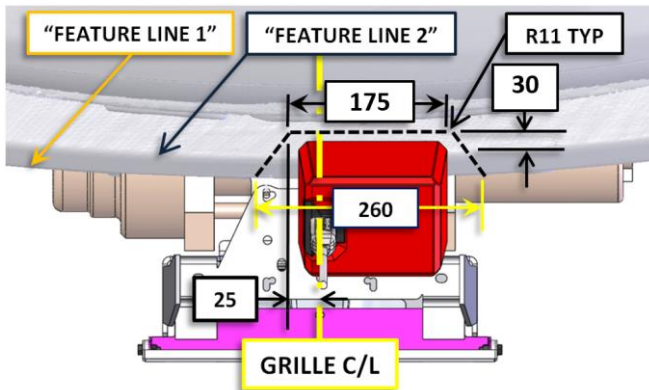

39. **Warn XD9000, 9.5XP, M12, M8000** (with Solid State Control Box): Tape, and mark out dashed lines shown at left using "feature line 2" as a guide and terminating on "feature line 1", then carefully use a multi-tool to trim bumper along "dotted" lines, removing centre section indicated.
40. Apply pinch weld to trimmed area.



Warning: Cutting operations can result in flying debris. Safety equipment should be worn.

TOP VIEW

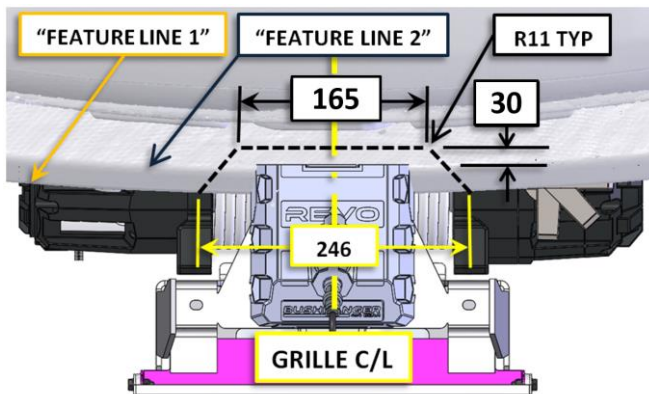

41. **Bushranger REVO** (With Ctrl Box mounted horizontally): Tape, and mark out dashed lines shown at left using "feature line 2" as a guide and terminating on "feature line 1", then carefully use a multi-tool to trim bumper along "dotted" lines, removing centre section indicated.
42. Apply pinch weld to trimmed area.



Warning: Cutting operations can result in flying debris. Safety equipment should be worn.

TOP VIEW

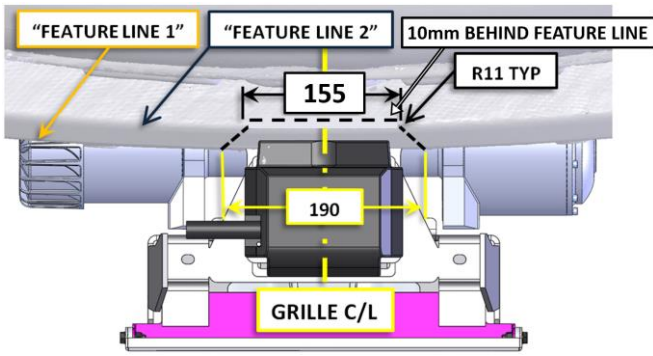

43. **Smittybilt GEN 1 & 2:** Tape and mark out dashed lines shown at left following "feature line 2" and terminating on "feature line 1" then carefully use a multi-tool to trim bumper along dashed lines, removing centre section indicated.

44. Apply pinch weld to trimmed area.



Warning: Cutting operations can result in flying debris. Safety equipment should be worn.

RHS – FRONT VIEW LHS OPPOSITE

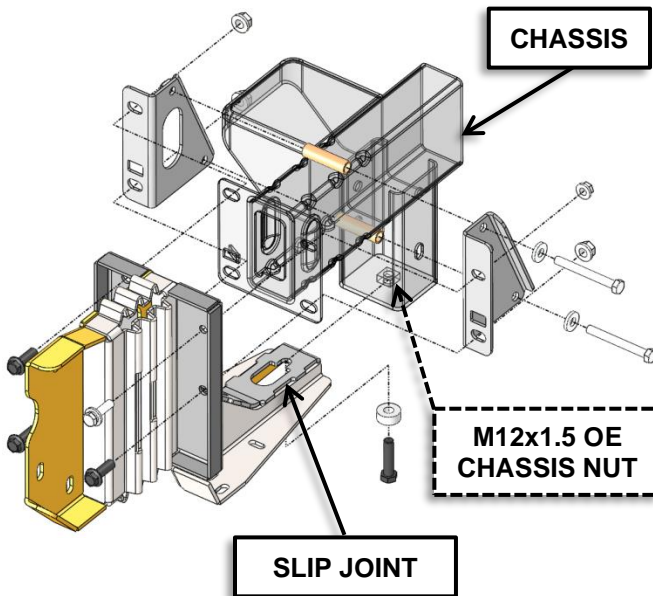

Assemble mount brackets to chassis:

45. **RHS shown, LHS opposite:** Loosely fasten the chassis mounts and rear brackets to the front of the chassis using; 6x Bolt Hex Head Flange Screws M12x1.25x35, 6x Nut Flange M12x1.25, 2x Screw SEMS M10x1.5x40, 2x Nut Flange M10x1.5. Insert 4x chassis crush tubes between the rear mount brackets and loosely secure with 4x Bolt Hex Head M10x1.5x90 and 4x Washer M10x25x4.

46. Loosely secure the slip joint at the chassis base using; 2x Bolt Hex Head M12x1.5x50, 2x Spacer M12 x OD29 x ID12.5x12 into the OE chassis nut located inside the base of the chassis.

RHS – REAR VIEW (ASSEMBLED) LHS OPPOSITE

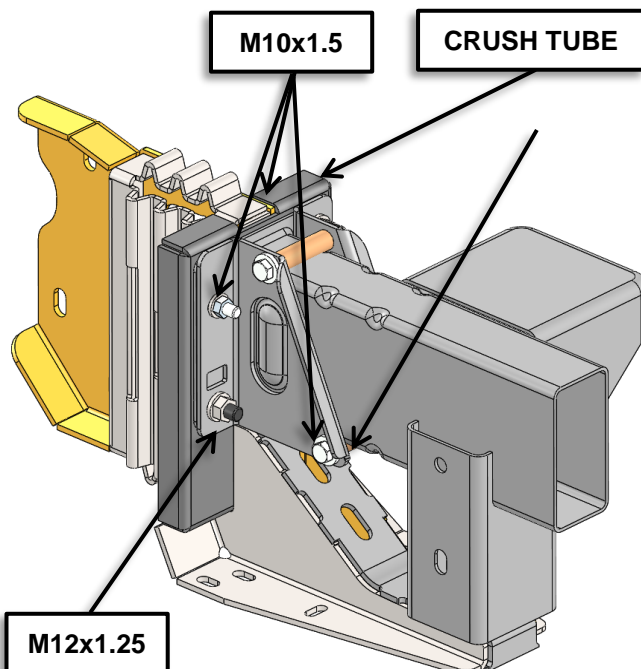

RHS – LHS Mounts Assembled:

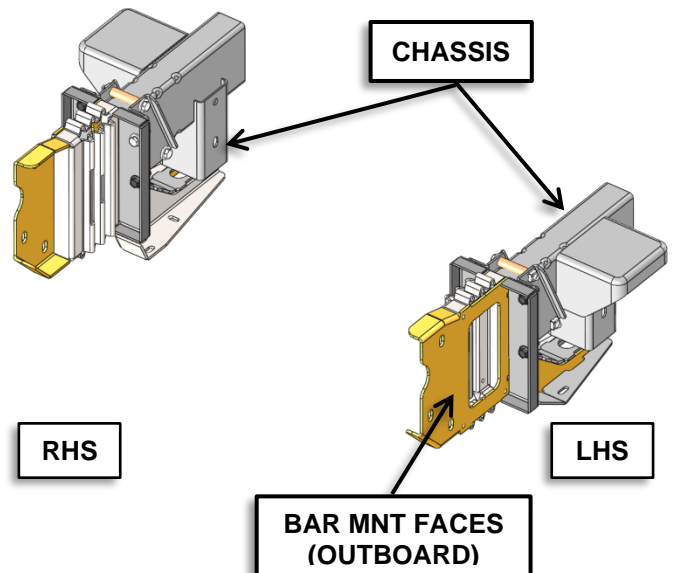

FRONT VIEW – BAR MOUNT FACES

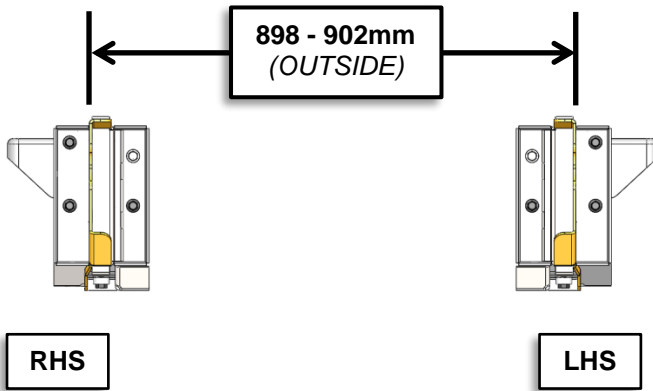

47. Check that the upright mounting faces are vertical and approximately 898 - 902mm apart overall.
48. Begin tightening all fasteners starting with 2x M12x1.5x50 chassis base screws, 6x M12x1.25 and 2x M10x1.5 front chassis mount screws ensuring that the mount brackets pull up evenly at all secured locations until final torque is reached.

 M12x1.5 PC 10.9 – 92Nm

 M12x1.25 PC 8.8 – 80Nm

 M10x1.5 PC 8.8 – 44Nm

Note: If fitting a winch proceed using fitting instructions 3789337 supplied with 3501000 winch install kit. Once the winch is fitted, please continue to step 52. If no winch is being fitted continue from step 49.

49. Slide the winch cover panel from the bottom up until it is level with the top face of the bar.
50. Fit the winch cover panel to the bar using 4 x M6 x 25 hex bolts, flat washers and nyloc nuts.

Warning: Be careful not to scratch the finish of the winch cover panel.

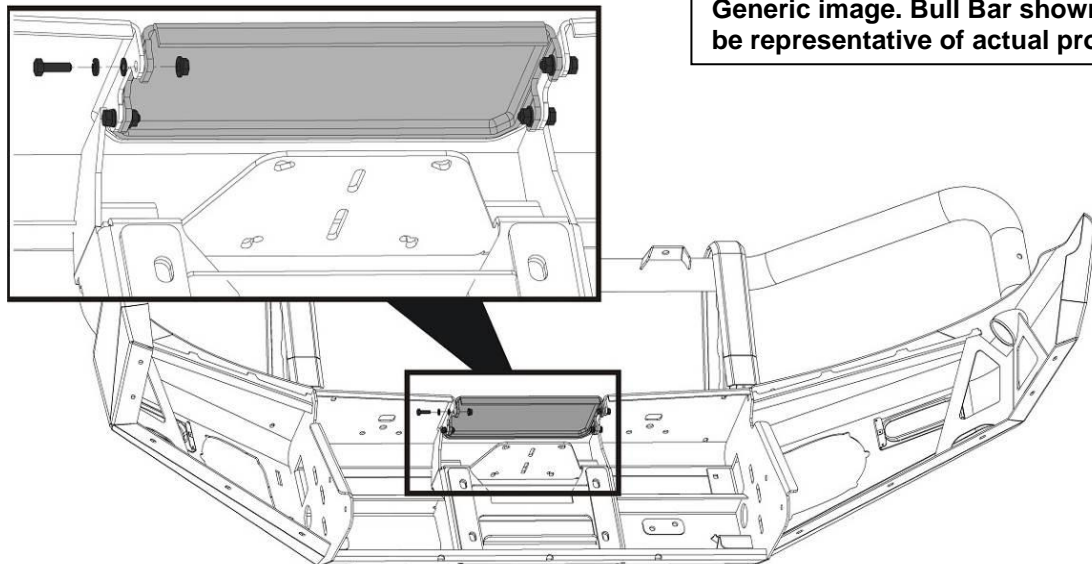

51. Fit the number plate bracket to the top face of the lower-centre pan on the bar using 3 x M6 x 25 hex bolts, flat washers and flange nuts.

Note: If you are fitting a winch, fit the folding number plate bracket supplied in winch install kit “3501000 SUMMIT BAR WINCH INSTALL KIT” – See fitting instructions 3789337

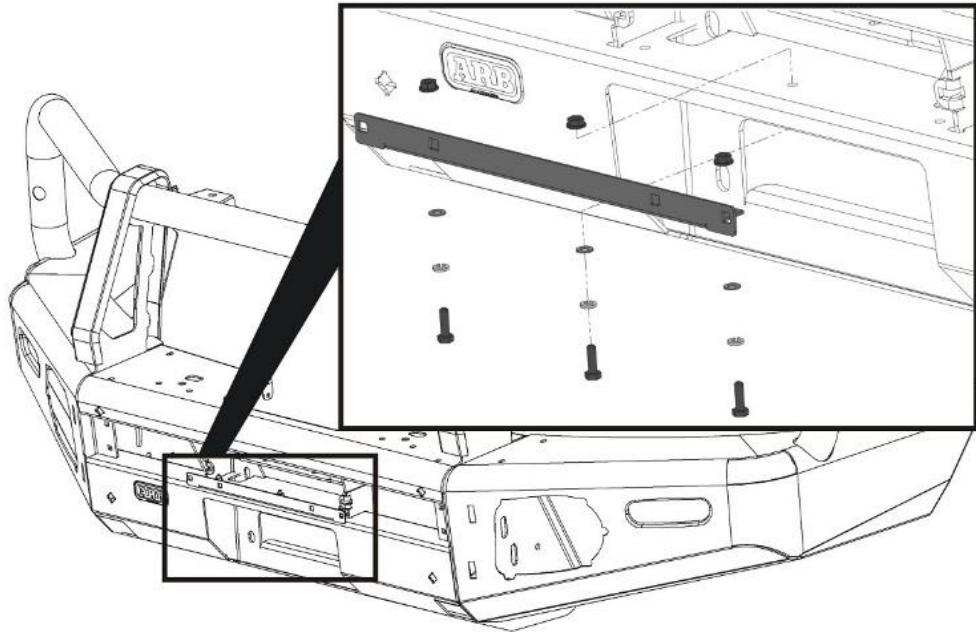

Note: The following steps show the fitment of the plastic moulded parts. The mouldings are supplied in kits along with all fasteners required for fitment. It is important that the fasteners supplied with each kit are only used for the mouldings from the same kit.

The kits included in this bar kit are as follows:

52. Layout the contents of each of the following kits ensuring the contents are kept separate from each other.

Kit No.	Description
5100200	BUFF KIT 2PCE FRONT SECTION
5100210	BUFF KIT 2PCE REAR UPRIGHT BAR
3500880	SPLIT PAN MESH KIT
3163082	FOG SURROUND KIT

53. For this fitment the grille panel **DOES NOT** need cutting. Please install as-is.

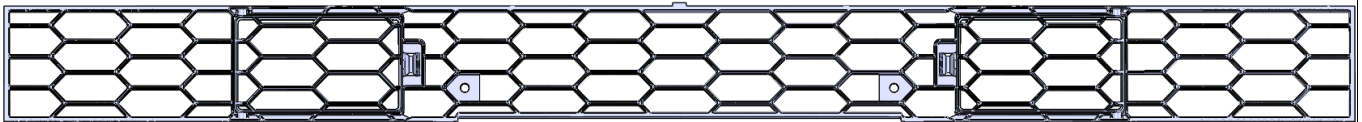

54. Insert the 6 x plastic grommets into the 6 square holes in the front face of the bar.

55. Insert the grille into the bar so that the hatches open outward (facing the front of the bar).

56. Attach the grille to the centre of the bar using the short screws into the grommets fitted above.
57. Attach the ends of the grille to the bar using the longer screws, through the clamp plates into the remaining grommets.

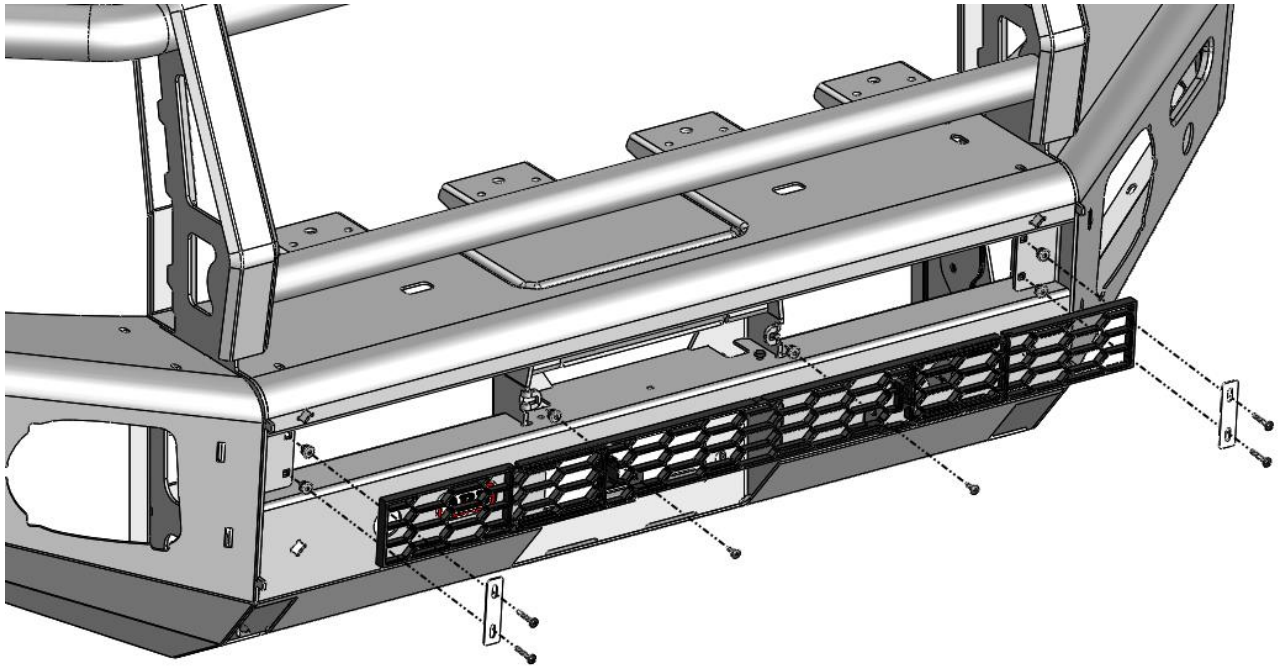

58. Fit the rubber intersection mouldings to the base of each upright cover strap.

Generic image. Bull Bar shown may not be representative of actual product.

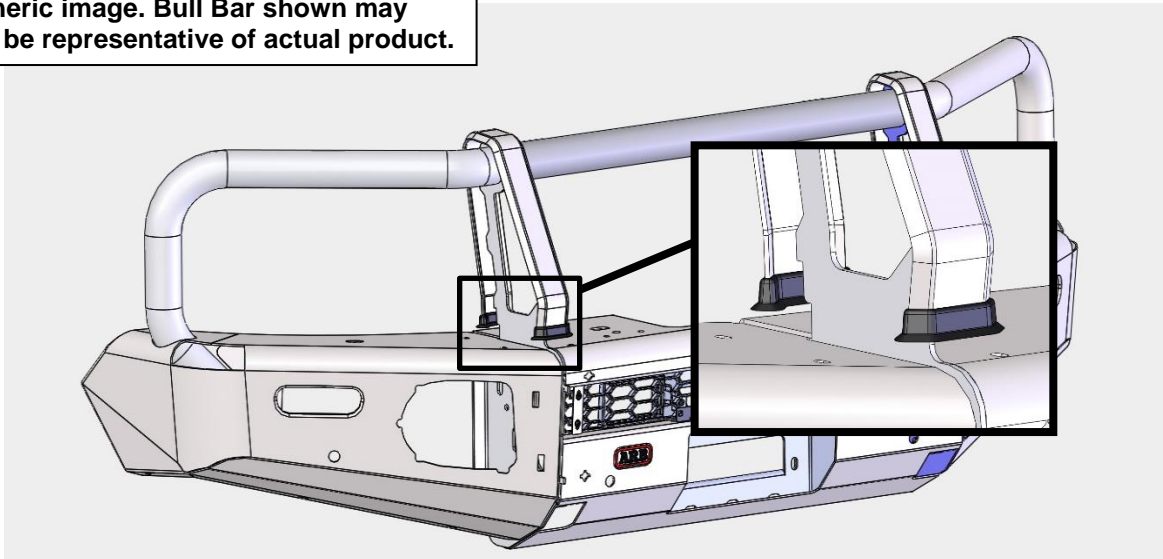

59. From the rear of the bar, slide the rear buffer sections under the rubber mouldings.
Fit 4 x screws and washers. Do not tighten screws. Leave enough play in buffers for adjustment later.
Note: Ensure that the skirts of the rubber intersection mouldings are not folded back on themselves and are sitting flat against the buffers.

Generic image. Bull Bar shown may not be representative of actual product.

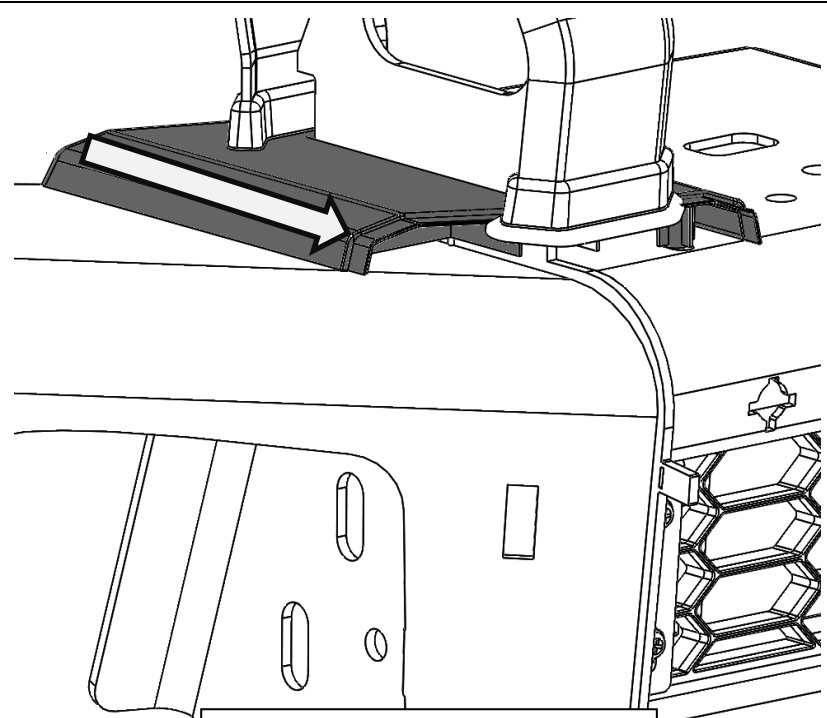

Fit washers under screw heads

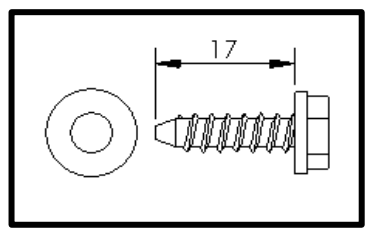

60. By aligning the front buffer with the tongue of the rear buffer, attach the front buffers to the front face of the bar. Ensure each buffer sits flat against the face of bar and is keyed into the top section of the rear buffer.

Secure wing side using retaining clips.

Secure inner side using the angled cup washers, flat washers and screws.

The widest point of the cup washers goes to the top of the bar.

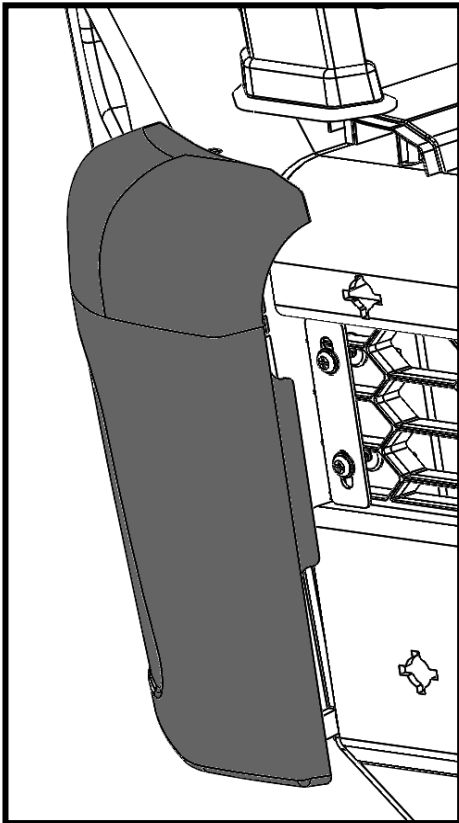

Generic image.
Bull Bar shown
may not be
representative of
actual product.

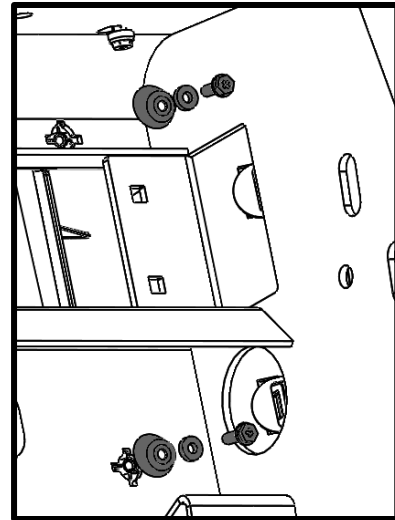

Fit washers under screw heads.

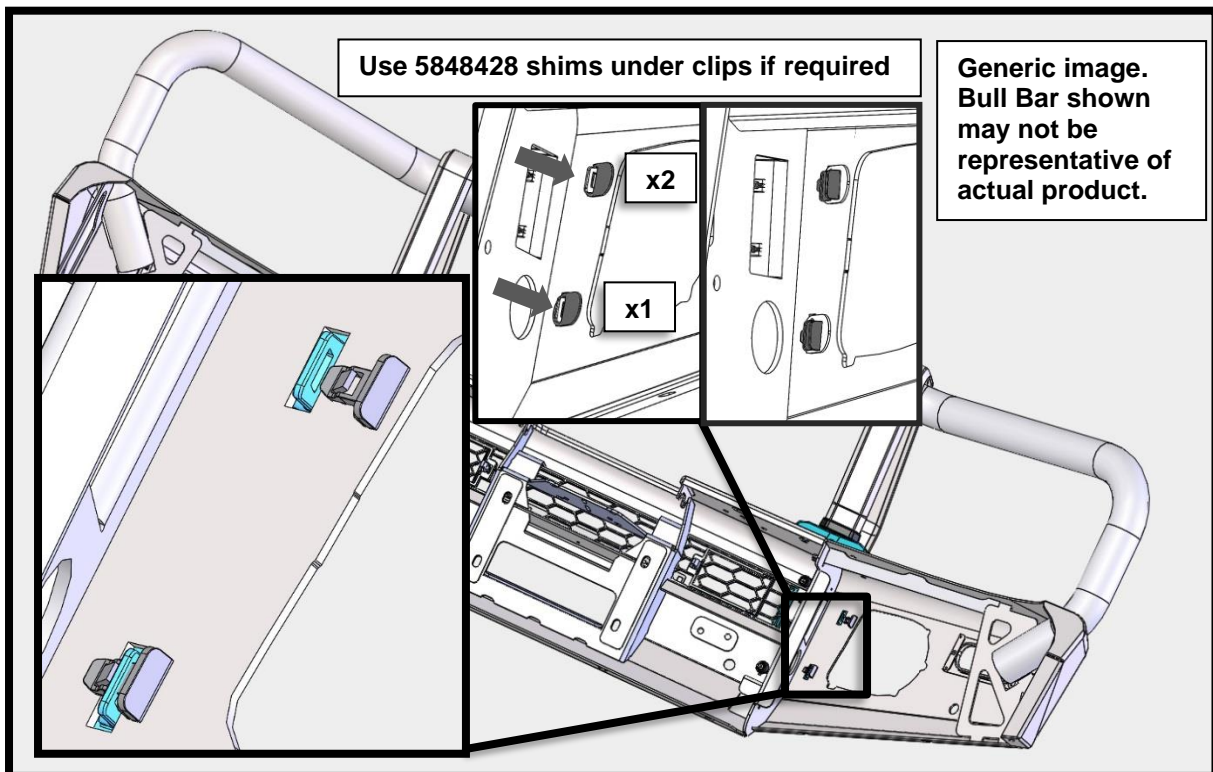
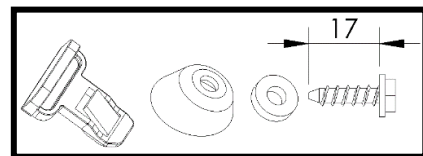

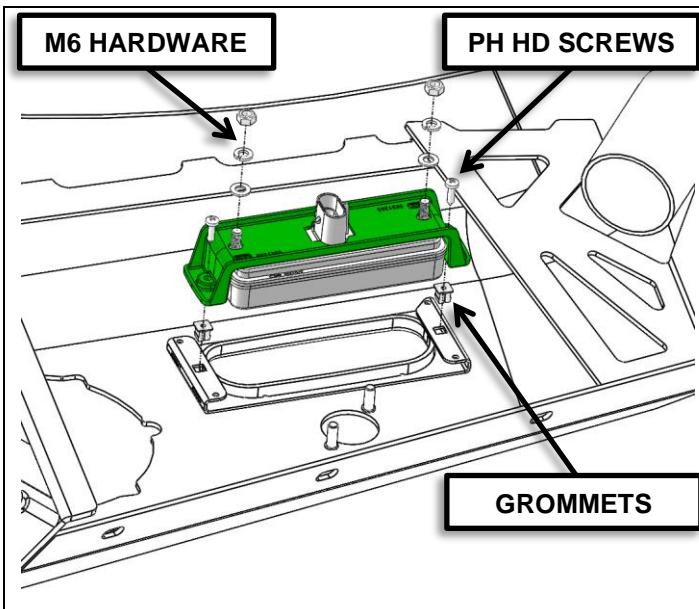

61. Fit the small plastic (square) grommets to the bar and attach the combination LED lamps to the bar using the Phillips head screws and M6 nuts and washers provided with the lamp kit.

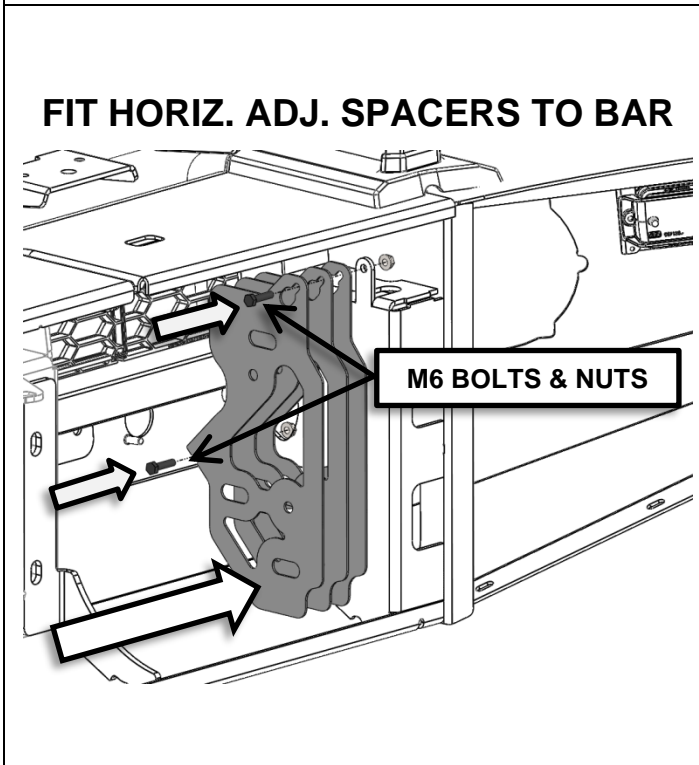
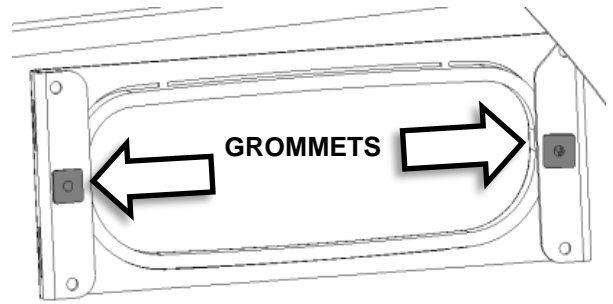

62. Fit an equal number of 2mm packers to the inside of the RH and LH bullbar uprights as required using M6 hardware provided. (Maximum of 3 per side shown at left)

The total clearance between the bull-bar mounting faces and the mounts should be roughly 1 - 2mm.

SPACERS FITTED: (RHS SHOWN)

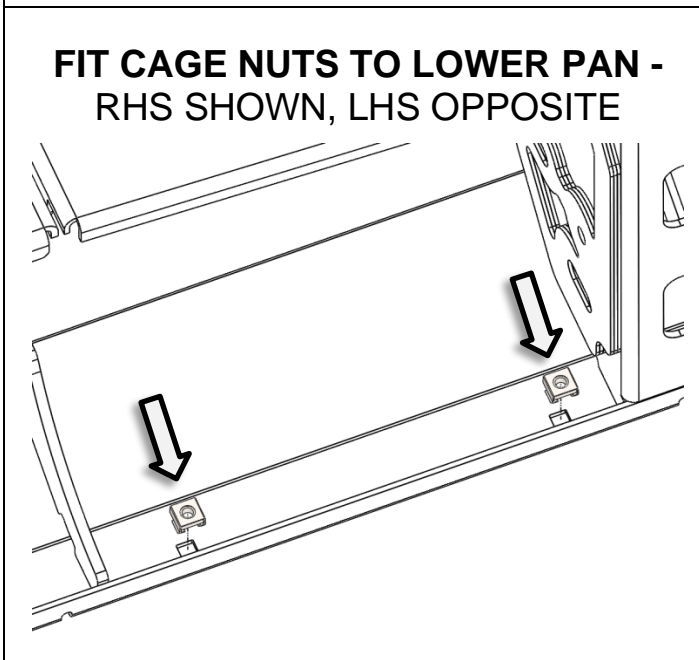
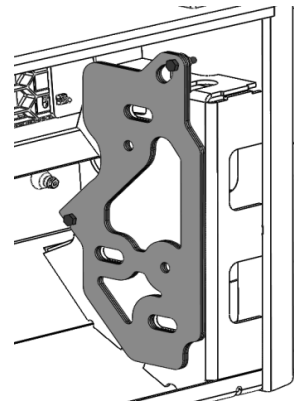

63. Fit the 4 longer leg M6 cage nuts to the lower pan of the bull bar as shown.

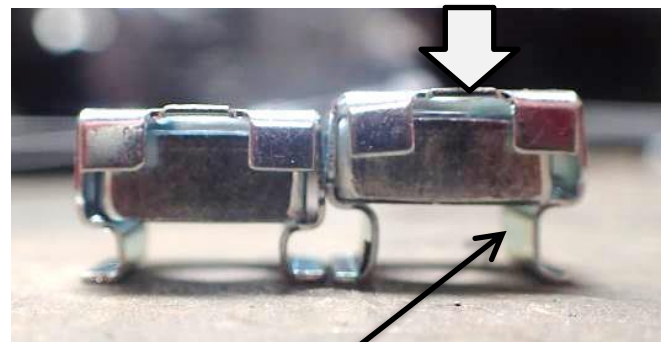

USE M6 CAGE NUT - WITH LONGER LEGS

ROUTE HARNESS THROUGH UPRIGHT HOLES

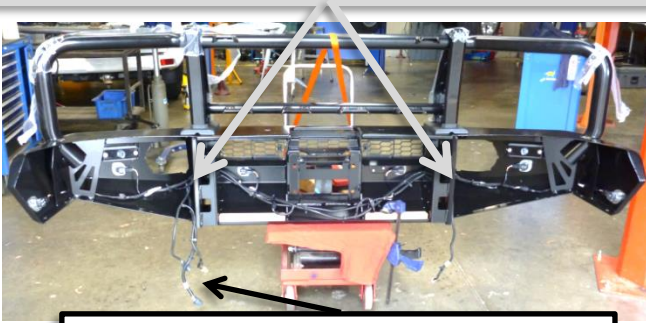

ALL VEHICLE CONNECTOR(S) ON LHS

Fit OE Lamp Harness to Bar

64. Fit the lamp harness removed from the bumper to the bull bar prior to assembling to vehicle.
65. Route the outboard harness leads through the large holes in the uprights, positioning the vehicle connector on the left.
66. Secure all looms to bar using cable ties provided.

FIT PLUGS TO BAR - RHS SHOWN, LHS OPPOSITE

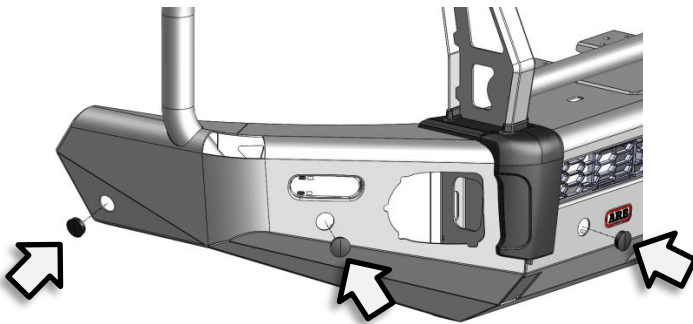

67. **Non-Sensor models:** (eg Express) Locate and install the six (6) sensor hole blanking plugs provided in the kit to the front of the bar.

PLUG FITTED: (REAR VIEW SHOWN)

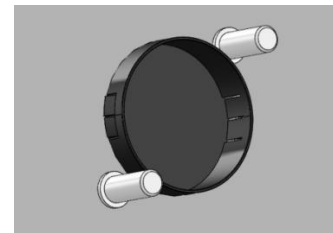

**FIT FPA SENSORS TO BAR
RHS SHOWN – LHS OPPOSITE**

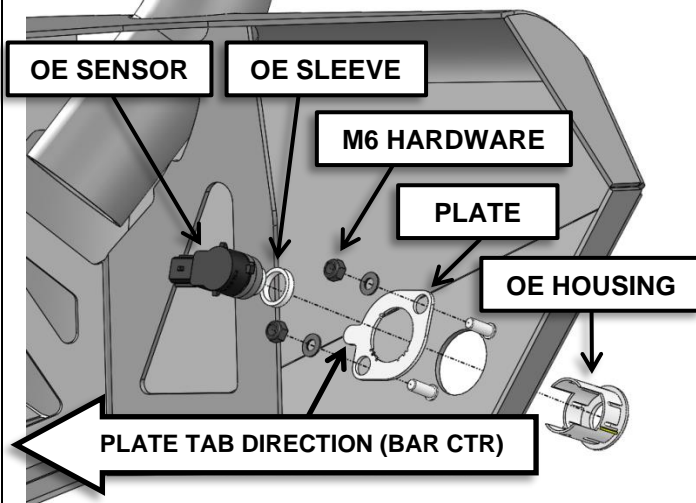

FPA Sensor Models; (eg Laramie)

68. Extend ALL six (6) sensor leads by connecting the 6x 350mm long extension cables provided to the OE sensor plugs.

6821356 KIT



**SENSOR PLUG END ORIENTATION
RHS SHOWN – LHS OPPOSITE**

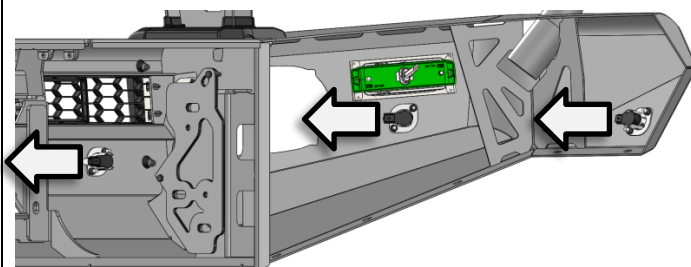

69. Locate the 6x OE FPA sensors, Silicone sleeves and housings removed earlier then carefully assemble to bar in this sequence; a) 6x sensor clamp plates to bar using M6 hardware provided (*with orientation tabs on ALL plates pointing towards centre of bull bar*) ensuring that they sit flat against the rear face of the bar avoiding the welded stud heads, b) 12x M6 washers and c) 12x M6 Nyloc nuts. Then assemble the 6x OE housings into the front of bar until centred in the bar opening and seated securely in the sensor mount plates. Finally install the OE FPA sensors with OE Silicone sleeves into the OE housings from the rear of the bar until securely seated in the OE housings.

CAUTION: Ensure that the OE sensors and matched OE housings are assembled in the corresponding location and orientation as removed from the OE bumper earlier.

70. Secure loom with cable ties provided.

 **M6x1.0 – 9Nm**

DO NOT PAINT SENSORS



NOTE: *Painting over sensors is not recommended as sensor operational faults can result. ARB recommends purchase of correctly colour coded sensors from a RAM dealer.*

HINT: Use an elevating trolley to aid installation

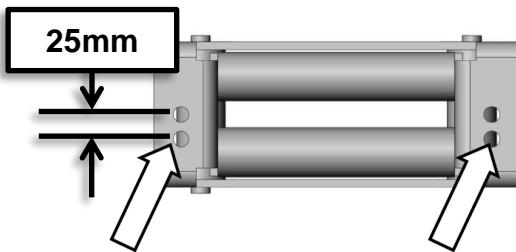

Install Bar on Vehicle

71. Apply some low tack film around the Bar and/or vehicle to protect the Bar and vehicle during alignment and assembly.
72. With the assistance of another person, place the bar on the elevating trolley.
73. Ensure all other aftermarket accessories such as driving lights/winch/UHF aerial have been fitted to the bull bar.

WARNING: *Due to the weight of the bar and winch if fitted, it is advised that you use some form of mechanical assistance when lifting the bar onto the vehicle such as an elevating trolley.*

NOTE: Winch Roller Fairlead must be drilled to 25mm offset if not already done so.

FIT M12 FLANGE BOLTS & NUTS RHS SHOWN – LHS OPPOSITE

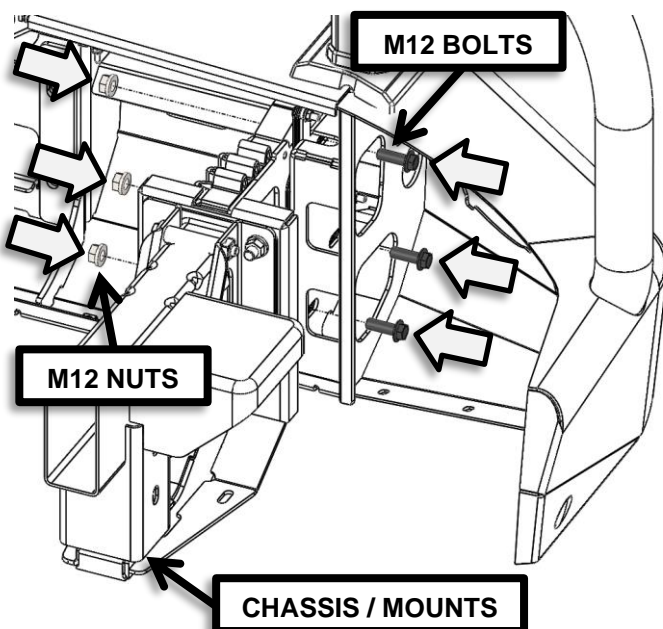

74. With the aid of another person, carefully lift and align the bar with the chassis mounts on the vehicle then position and loosely bolt the bull bar to the mounts using 6 x Hex Head Flange Bolts M12x1.25x35 PC8.8 BTZP and 6x M12x1.25 PC8 TZP flange nuts.

NOTE: DO NOT DO UP TIGHT

RHS SHOWN – LHS OPPOSITE

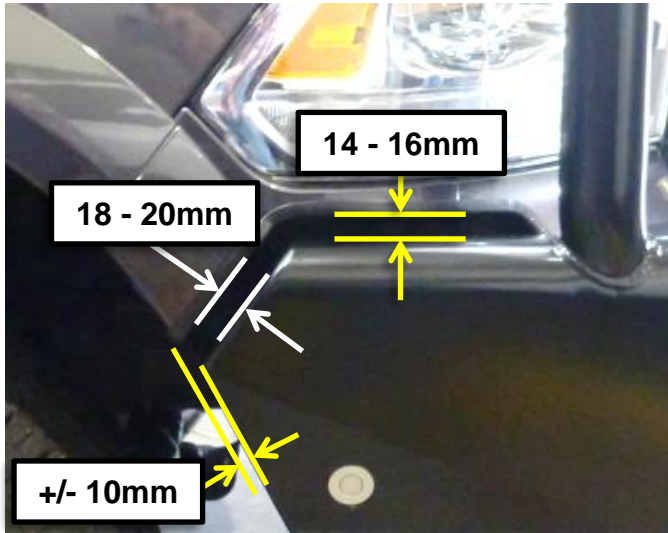

75. Adjust position of Bar such that;
 - a. It is level with trimmed Bumper profile
 - b. There is even gapping all around as shown at left
 - c. There is a minimum of 10mm clearance between Bar (&/or fitted accessories eg Winch Control Box...) at the front of the vehicle
 - d. CB Aerial / Brackets are either vertical or leaning slightly rearward
76. Once Bar is visually in correct position, tighten 6 x Hex Head Flange Bolts M12x1.25x35 PC8.8 BTZP connecting Bull Bar to Mounts.



M12x1.25 PC8.8 – 80Nm

(NB: IMAGE INCLUDES OPTIONAL FOG LAMPS , DRIVING LIGHTS, LIGHT BAR AND WINCH FITTED)

**DRILL 2x Ø10mm PINNING BOLT HOLES
RHS SHOWN – LHS OPPOSITE**

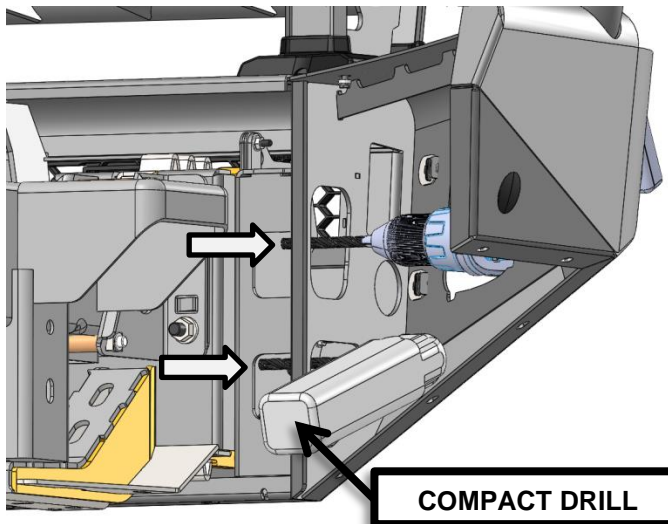

77. Once satisfied with the position of the bar on the vehicle drill the two Ø10mm pinning bolt holes per side through the upright mounts with a 10mm drill bit. The upper set of holes can be drilled with a regular power drill through the fog light openings, while the lower set require a compact power drill as indicated.
78. Apply some anti-corrosion touch up paint to the drilled areas.

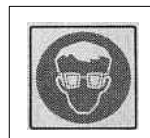

Warning: Cutting operations can result in flying debris. Safety equipment should be worn.



79. Measure the clearance between the RH vehicle fender and the RH bull-bar wing. Repeat on the LH side to confirm that the bar is sitting centrally on the vehicle.
80. If not, remove the bar from its mounts and shift the required number of 2mm packers installed on the bull-bar mounts from one side to the other. Next re-fit the bar on the mounts lining up the Ø10mm holes drilled in previous steps.

**FIT M10 PINNING BOLTS & NUTS
RHS SHOWN – LHS OPPOSITE**

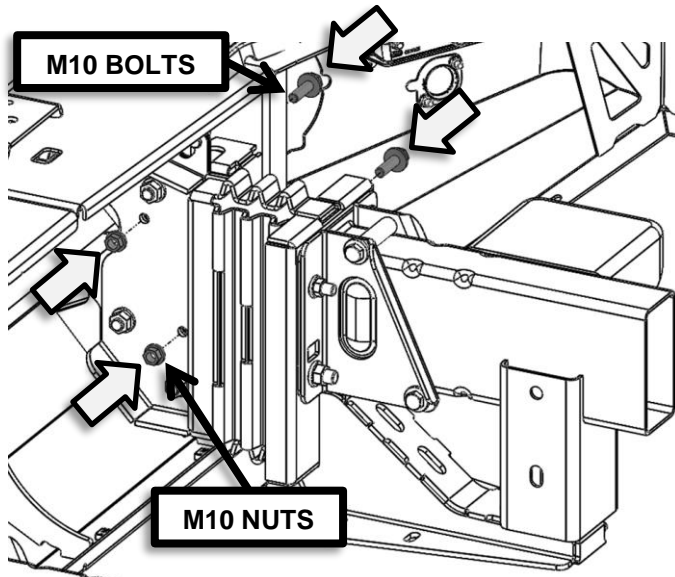

81. Once satisfied with the fitment of the bar to the vehicle, fit the 4x M10 x 40 SEMS bolts and 4x M10 flange nuts to the RH & LH mounts (4 off - 2 per mount).

Torque fasteners to specification below;

 **M12x1.25 PC 8.8 – 80Nm**

 **M10x1.5 PC 8.8 – 44Nm**

**INSTALL ARB FOG LIGHT SURROUNDS
RHS SHOWN – LHS OPPOSITE**



82. Assemble and install ARB Fog Light surrounds (P/No. 3163082) as per instructions P/No. 3789190 supplied with surround kit.

Note: Optional fog lamps shown can be installed at this point as per fitting instruction supplied with fog lamp kit no. 3500910

***HINT:** loosely fit top bracket to fog light surround, then insert into Bull bar aperture, top outside corner first.

83. If installing fog lights to non factory equipped vehicles, use ARB wiring loom 3500520.

**CONNECT ALL LOOMS & LIGHTS
LHS SHOWN**



84. Connect all relevant looms to vehicle; Indicator, Fog and FPA Sensor (if present) and check operation.

CAUTION: Cable-tie all looms and keep clear of sharp edges and moving parts.

FIT CROSS BRACE TO BAR & MOUNTS

(REAR VIEW)

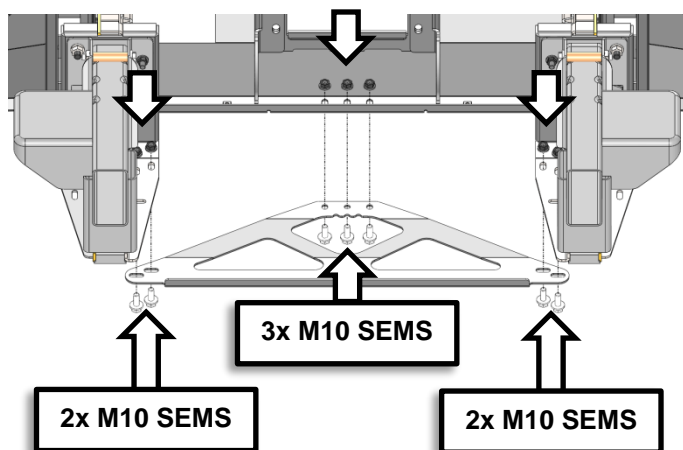

85. Fit the cross brace to underside of lower pan and gussets on mount brackets. Use 7x Black M10 x 30mm SEMS bolts and 7x M10 flange nuts.



M10x1.5 PC 8.8 – 44Nm
CROSS BRACE ASSEMBLED
(UNDERSIDE VIEW)



FIT WING UNDERPANEL BRACKETS RHS SHOWN – LHS OPPOSITE

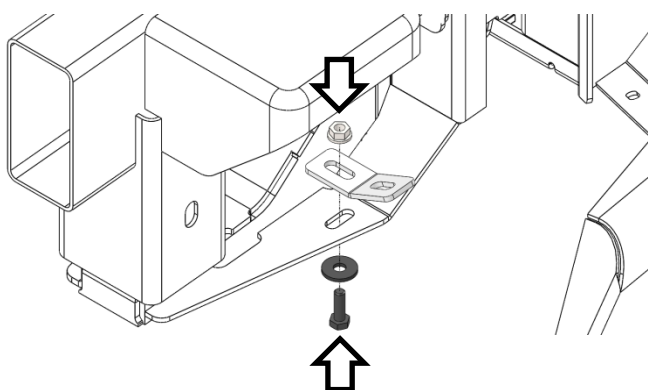

86. Fit both wing panel brackets to the holes in the outer gusset of the chassis mounting brackets using 2x M8 bolts, 2x M8 washers and 2x M8 flange nuts.



M8 - 22 Nm.

BRACKET ASSEMBLED
(RHS SHOWN)



FIT CAGE NUTS TO WING UNDERPANELS RHS SHOWN – LHS OPPOSITE

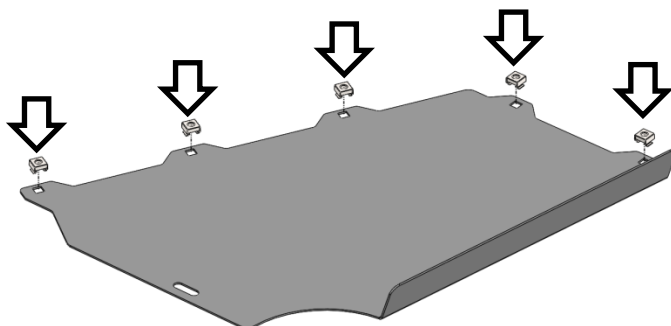

87. Fit 5 x M6 cage nuts to each wing splash panel as shown on *inside* faces. Repeat for LHS.

88. Fit panels up inside wings; secure using 10x M6 x 25 black bolts and 10x M6 washer sets. Fix panel to bracket using 2x M8 bolts and M8 washer sets and 2x M8 flange nuts.



M6 - 9 Nm.



M8 - 22 Nm.

FIT WING UNDERPANELS TO BULL BAR RHS SHOWN – LHS OPPOSITE

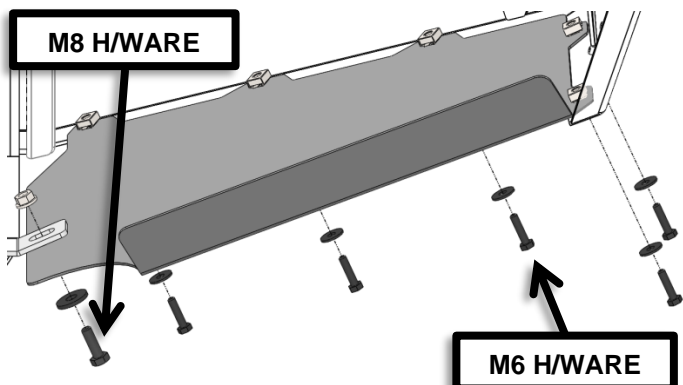

WING PANEL ASSEMBLED
(RHS SHOWN)



FIT STONE GUARD TO BULL BAR

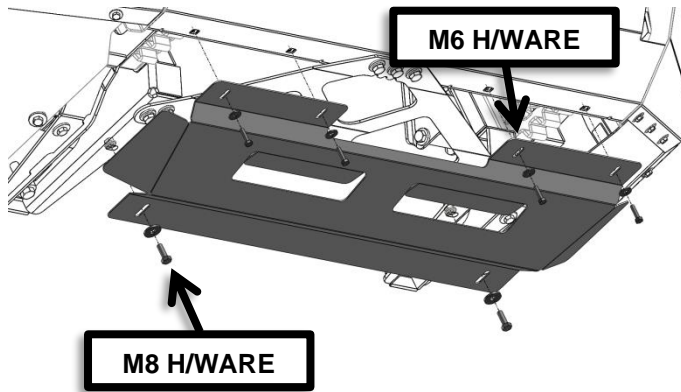

89. Secure stone guard to front/underside of bull bar using 4x M6 bolt and washer sets into 4x M6 cage nuts installed previously into lower pan.
90. Secure rear of stone guard to inboard gussets on chassis mounts using 2x M8 bolt, washer and flange nut sets.

 **M6 - 9 Nm.**

 **M8 - 22 Nm.**

TRIM WHEEL ARCH LINERS

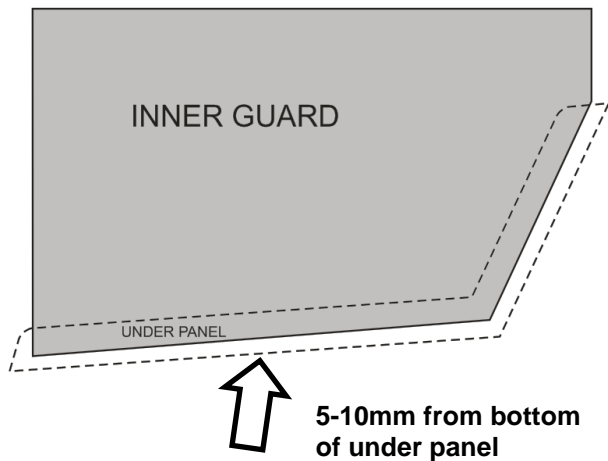

Mark Out & Trim OE Wheel Liners on Vehicle

91. Mark lines onto the OEM Wheel Liner Guards (LH & RH) using the wing under panels as a guide ensuring enough guard remains so that it may be neatly tucked/secured behind the under panel return.
92. Carefully cut along marked lines using a multi tool or jig-saw.



Warning: Cutting operations can result in flying debris. Safety equipment should be worn.

FIT NUMBER PLATE

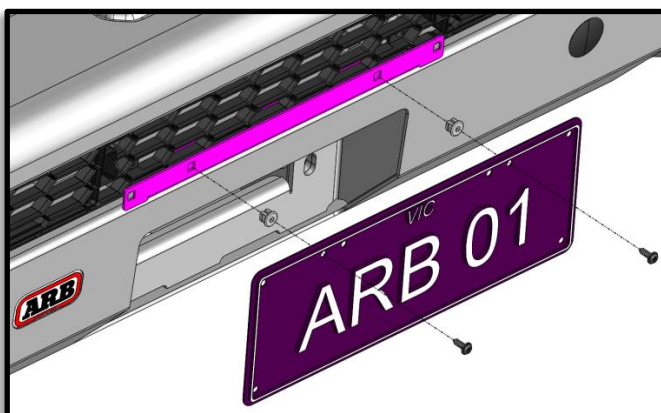

93. Fit the plastic plugs into the square holes in the licence plate bracket. Fit the licence plate to the bull bar using the black self-tapping screws.

NOTE: Omit this step if a Winch has been fitted as it uses the top mount flip-up number plate included in the winch kit...

94. Discard all remaining fasteners left over.

NUMBER PLATE FITTED



FITTED PRODUCT

NOTICE: ONCE SUMMIT BAR IS FITTED:

- ◆ Ensure all bolts are tensioned correctly.
- ◆ All wiring is clear of sharp edges or moving surfaces and secured properly.
- ◆ Piping is secured well away from sharp or moving components.
- ◆ Check operation of winch, if fitted.
- ◆ Check all wiring and connections to turn signal lamps, sensors, headlamp washers etc. are functioning correctly.
- ◆ Misalignment of parking sensor to hole in bull bar may cause malfunction if installed.
- ◆ Test operation of parking sensors after fitment if installed.

NOTE:

If parking sensors are fitted, do not add any accessories to the Bull Bar on or around the sensors as this may affect the function of the sensors.

Sensors may not function well under the following conditions:

- ◆ After the vehicle has been sitting out in hot or cold weather.
- ◆ When the system is affected by electrical equipment or devices generating an ultrasonic wave.
- ◆ When operating in bad weather

FITTED PRODUCT on RAM 1500 LARAMIE

