

FITTING INSTRUCTIONS

(AIRBAG OPERATING HEIGHT & MAXIMUM PRESSURE)

OA6014S

IMPORTANT

Your airbag kit is supplied with ready to install Airbag assemblies. The supplied height of the Airbag assembly is set for installation and initial inflation. Adjust the suspension mounting position heights to maintain the Airbag assembly at the supplied height during installation.



SUPPLIED HEIGHT



CRUSHED / EXTENDED



⚠ DO NOT crush or extend the Airbag from the supplied height during installation or initial inflation.

MAINTAIN THE AIRBAG ASSEMBLY AT THE SUPPLIED HEIGHT DURING INSTALLATION & INITIAL INFLATION

SEE OTHER WARNINGS AND IMPORTANT INFORMATION IN THE PRODUCT MANUAL

MANUAL INFLATION

Maintain the Airbag assembly height during initial inflation by adding small amounts of air while slowly lowering the weight of the vehicle onto the suspension. Maintain the Airbag assembly height while transferring the load by increasing the airbag pressure to support the load.

⚠ If the Airbag begins to crumple or crease, STOP, take a small amount of load off of the Airbag, add a small amount of air and continue.

AUTOMATIC INFLATION

⚠ Some automatic suspension systems will require specific requirements for the system to be active, please ensure you are conversant with the process prior to installation.

Inflation via the automatic system is carried out based on suspension position. Therefore, to inflate the Airbag, the suspension height needs to be gradually lowered until the airbag begins to fill. The system will inflate the Airbag slowly as the load is transferred onto the suspension.



- ⚠** This air suspension system is designed to replace the original vehicle manufacturer's suspension – it is not designed to carry more load than the original OEM suspension.
- ⚠** The kit is designed to suit a standard vehicle configuration – modifications to the vehicle outside the kit design parameters may adversely affect fitment and operation such as:
 - Height changes outside any noted in the kit specification.
 - Larger dampers (Shock Absorbers)
 - Wheel and tyre changes
 - Exhaust changes.
- ⚠** If your vehicle is fitted with a brake proportioning valve or stability control system it is important to ensure this is maintained and adjusted according to the vehicle manufacturer's instructions.
- ⚠** It is recommended that only a properly qualified person installs the product and carries out maintenance. If you are not qualified and attempt to carry out such work ensure that all safety equipment is used and safety standards are met.
- ⚠** Ensure that you have read the full Product Manual before attempting to fit the product.
- ⚠** Ensure the Product Manual is kept with the vehicle and that any vehicle owner and/or operator is fully advised on the system and its operation before attempting to drive or operate it.



LHS = LEFT SIDE OF THE VEHICLE WHEN FACING FORWARD

STEP 1 - BUMP STOP SPACER

Remove the bump stop from the chassis then re-fit with the spacer between it and the chassis using the longer M8 bolts provided.



STEP 2 - PREPARE AIR LINE TUBING

The airline is supplied with split protector tube pre-fitted to shield the air line during and after installation. Decide on a suitable route for the air line from the airbag to the factory airline location to avoid direct heat from engine, exhaust pipe, and away from sharp edges.

Uncoil the airline tubing being careful not to fold or kink it and cut to length to suit the chosen route. Once routed, the protector tube is pulled back later to prepare the protected airline.

DO NOT CONNECT OR SECURE THE AIR LINE AT THIS POINT

Refer to below Fit Air Line Tubing step for further detail.

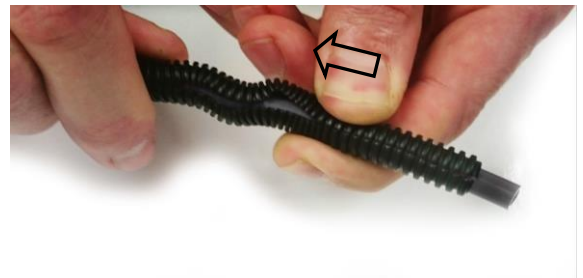

STEP 3 - REMOVE COIL SPRINGS

Remove the rear coil springs from the vehicle as per the manufacturer's specifications. The shock absorbers will need to be removed from their lower mounts and the sway bar will need to be un-bolted from the axle.

STEP 4 - PREPARE PASSENGER SIDE UPPER SPRING SEAT

The passenger side upper fastening uses the existing rear hole in the upper spring seat and the existing inboard slot. Remove the wiring clip as shown to allow fitment to the inner slot.

Secure the wiring with supplied cable ties to ensure no damage.

Wear **appropriate** personal protective equipment (PPE) when doing this step.



STEP 5 - PREPARE DRIVER SIDE UPPER SPRING SEAT

Wear appropriate personal protective equipment (PPE) when doing this step.

The Driver side upper spring seat requires a 6.5mm hole to be drilled in the inboard position. Position the upper airbag mounting plate up to the spring seat using the existing rearward hole in the upper spring seat for the correct location. Mark the inboard hole position through the upper mounting plate as shown. Drill the hole in this position, remove and sharp edges and coat to protect against corrosion.



STEP 6 - FIT AIR SPRING ASSEMBLY TO VEHICLE

Set the airbag assembly in place on the lower spring seat with the lower post located through the spring seat. Position the upper airbag mounting plate up to the upper spring seat with the air fittings facing forward and fasten using the supplied M6 fasteners.

The passenger side upper uses the existing rearward hole and inboard slot and the drivers side upper using the existing rearward hole and drilled inboard hole.

You may need to raise the axle and/or add a small amount of air pressure to hold the top mount in position. The bottom mount simply sits down on and into the spring seat like the original airbag assembly.

Ensure that the airline from the air fitting is routed with clearance for full height sensor and suspension component range of movement.



STEP 7 - AIR LINE TUBING & FITTINGS - GENERAL NOTES

CUTTING

Only cut the airline tubing with a sharp blade making the cut as square as possible.

Always trim the tubing before re-inserting into the fitting.

⚠️ If you use a sharp utility knife or razor blade great care must be taken in all cases not to cut yourself during this operation.

CONNECTING & REMOVING

To connect:

Push the freshly trimmed tubing into the fitting as far as possible.

To remove:

First release the air pressure from the system. To withdraw the tubing, push and hold the collar on the fitting away from the tube and pull out the tubing.

Hint In confined spaces an open-ended spanner can be used to evenly depress the collar and remove the airline tubing.

CUT TUBING SQUARE WITH SHARP BLADE OR TUBE CUTTER

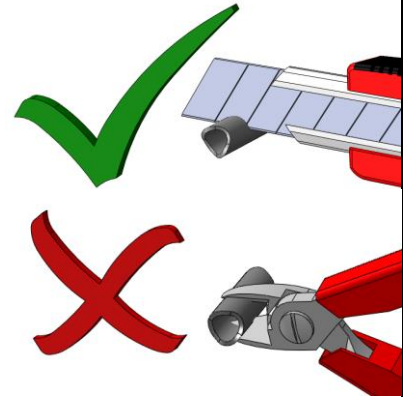

DO NOT USE PLIERS, SIDE CUTTERS OR PIPE CUTTERS

STEP 8 - POSITION YOUR INFLATION VALVES

Select a convenient location for the air inflation valves such as the bumper or the body of the vehicle. It must be protected from road damage and be accessible for air inflation equipment. Drill a 5/16" hole and install the air inflation valve using two 5/16" stainless steel washers as supports where required.

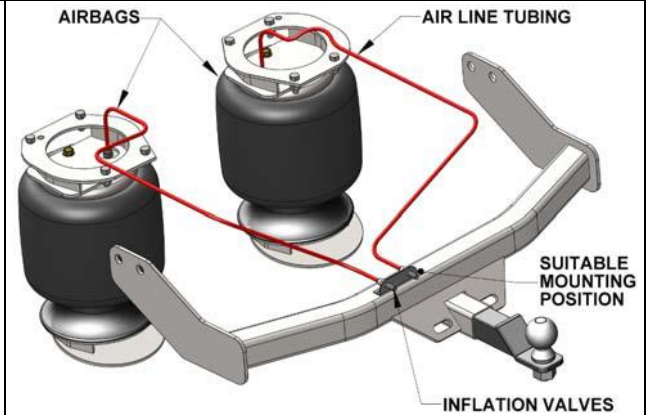
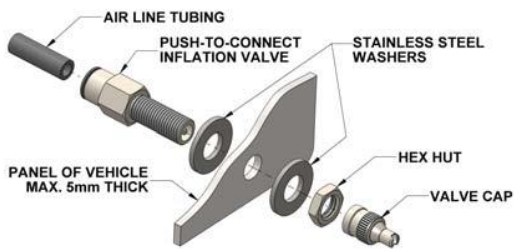

AIRLINE ROUTE SHOWN IS EXAMPLE ONLY SEE INSTRUCTIONS FOR SPECIFIC ROUTE

STEP 9 - FIT AIRLINE TUBING

Insert the tube at one end and route as above securing in place with the nylon ties provided. Trim and insert the other end as required.

STEP 10 - YOU ARE NOW READY TO TEST & CHECK THE SYSTEM

The airbag must be checked for the correct installed height, vertical alignment and clearances with the vehicle levelled out.

INFLATE the airbags until a level vehicle height is reached and measure the bag height between the mounting plates.

The AB0200 airbag in this kit requires a height of 11" to 13" to be maintained under all loads.

It is important to ensure that the airbag does not make contact with any other components in all load and height conditions.

If the centreline of the airbag end plates are misaligned in any direction more than the amount shown to the right, please contact Airbag Man on 1800 247 224 for further technical support.

Please note: Misalignment and angled installation at ride height is often required to ensure correct alignment through the suspension travel.

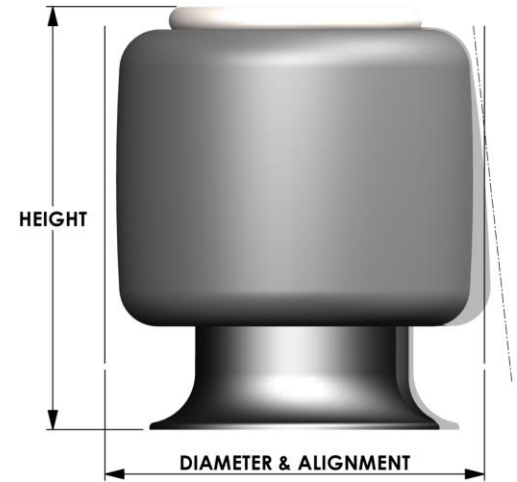

Standard airbag misalignment tolerance allowed is 20mm

STEP 11 - LEAK TEST

Once the inflation valves are installed, inflate the airbag to 50 psi (3.5 Bar) and check the fittings for air leaks with an applied solution of soap and water. If a leak is detected at a tubing connection then check to make sure that the tube is cut as square as possible and that it is pushed completely into the fitting. The tubing can be easily removed from the fittings by pushing the collar towards the body of the fitting and then pulling out the tube. If a leak is detected where the air fitting screws into the airbag, tighten the fitting slightly, until the leak stops.

STEP 12 - TO FINISH

Ensure the **WARNING** label is fixed in a prominent position in sight of the vehicle operator.

Ensure the Product Information Wallet is given to the vehicle owner/operator.

Ensure the vehicle owner/operator fully understands how to use the product.

All fixings should be checked for tightness after the first laden run and thereafter as per the original manufacturer's recommendations.

AIRBAG OPERATING HEIGHT & MAXIMUM PRESSURE

See operating instructions section for proper use and maintain the specific height below:

OPERATING HEIGHT

The AB0212 airbag in this kit requires a height of 9.0" to 11" under all loads.

Adjust and retain pressure up to the stated maximum to maintain the airbag operating height.

Failure to do so may result in product or vehicle damage not covered under warranty.

MAXIMUM PRESSURE

70 PSI (5.0 bar)

**IF MORE PRESSURE IS REQUIRED TO MAINTAIN THE OPERATING HEIGHT CALL
AIRBAG MAN ON 1800 247 224 FOR FURTHER TECHNICAL ADVICE**



FREECALL 1800 247 224



⚠️ Incorrect use of this air suspension product can result in damage to the airbag, associated parts and/or the vehicle, which is not covered under warranty.

⚠️ Ensure the airbags are maintained at the stated ride height at all times and the maximum pressure is never exceeded.