

## Kit Components



**CROSS-BAR KIT**

**LOCK BARREL KIT**

**END SUPPORT KIT**

**PLEASE NOTE**  
 Your End Supports may come fitted with height extenders (as shown in black) - depending on vehicle.

**PARTS LIST**

- 2 x CROSS-BARS
- 2 x BUFFER STRIPS
- 2 x UNDERCOVER STRIP LENGTHS(450mm ea.)
- 4 x END SUPPORT ASSEMBLIES
- 4 x REX END CAPS
- 4 x LOCK BARREL & KEY
- 1 x SECURITY KEY

**TOOLS REQUIRED:** Cutting Blade, Lead Pencil, Steel Rule, Measuring Tape - Please read instructions thoroughly before commencing installation.

## Fitment of Cross Bars to Vehicle

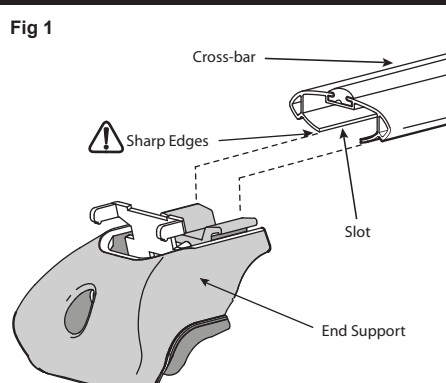
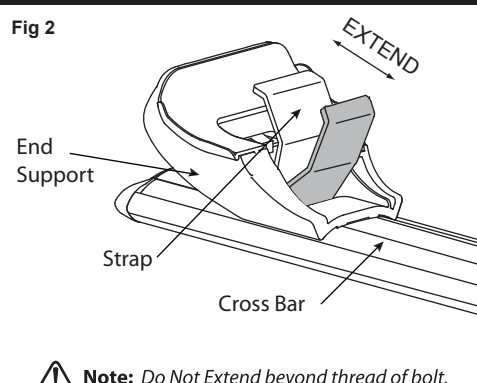
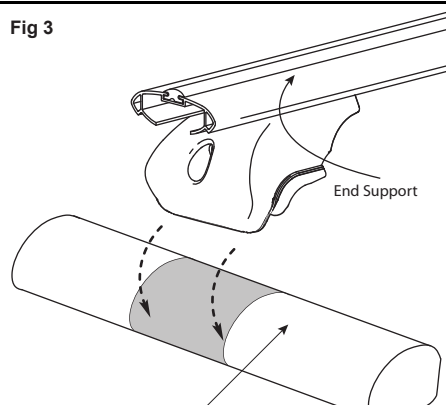
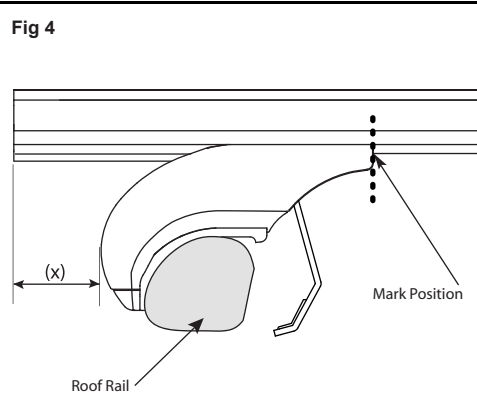
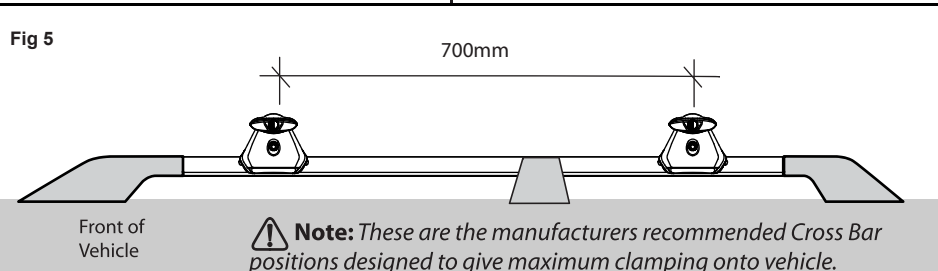
<p><b>Step 1</b></p> <p>Ensure that the roof rails are clean, free of dust and grease. Pre-assemble the End Supports into the cross-bars. Take care to avoid your hand coming into contact with any sharp edges.</p> <p>Remove all end-caps from crossbars to allow access for assembly of parts.</p> <p>Slide the end Support along to the desired position approximating its fixed position on the vehicle's rails. (Fig. 1).              Strap is to be held extended to allow the end support to be located onto the rail bars. (Fig.2)</p>	<p><b>Fig 1</b></p> 	<p><b>Fig 2</b></p> 
<p><b>Step 2</b></p> <p>Place the Cross-bar onto the vehicle rail. (Fig 3)              Make sure the over-hang of the cross-bars is even on both sides [denoted by (X) in Fig.4]</p> <p>Mark out the End Support bedding position on the rails vs. the Cross-bar. This marked position will indicate the required cut length of Undercover Strip (A). (Also refer to Fig. 7)</p>	<p><b>Fig 3</b></p> 	<p><b>Fig 4</b></p> 
<p><b>Step 3</b></p> <p>Using a measuring tape, measure the crossbars to be 700mm apart (Fig 5). Make sure the cross-bars are conveniently placed on the vehicle's roof whilst considering the following:</p> <ul style="list-style-type: none"> <li>- Sun-roof opening clearance</li> <li>- Roof-mounted Aerial clearance</li> <li>- Roof-rail middle supporting strut clearance (if fitted)</li> </ul> <p><b>Remove cross-bars from the vehicle.</b></p>	<p><b>Fig 5</b></p>  <p><b>Note:</b> These are the manufacturers recommended Cross Bar positions designed to give maximum clamping onto vehicle.</p>	

**Fitment of Cross Bars to Vehicle**

**Step 4**

With the cross-bars removed, line up the undercover strip with the cut-out on the cross-bar. Ensuring the 'Strip edge' and the 'crossbar cut-out edge' are aligned, mark the strip with a line that corresponds to the line you marked on the crossbar, as instructed in Step 2 of page 1. Using a Rule and a Blade, score a straight line and snap off this piece from the length of Undercover Strip. This becomes Cut Length (A) as shown in (Fig 6). Slide (A) as far in as possible. Do this for all four (A) strips. Insert all four End Supports and using the remaining Undercover Strip, insert into the remainder of the crossbar cut-out till fully covered. Cut to edge of crossbar all four (B) strips as shown in (Fig 7).

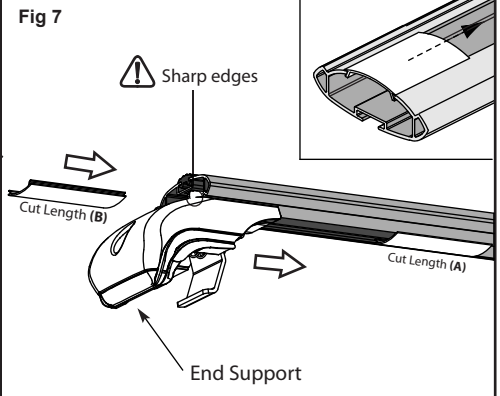
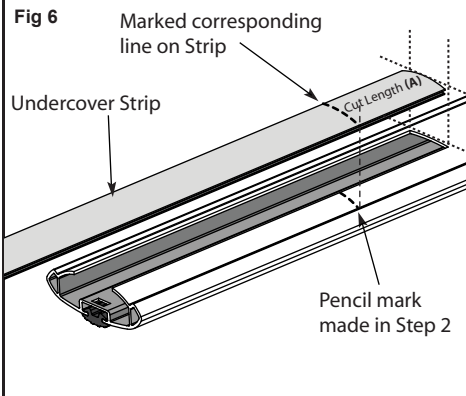

**Step 5**

**Refer to LB (Lock Barrel Kit) Fitting Instructions provided - for assembly of Locking Barrel into Endcap.**

**Step 6**

Pull back the buffer strip to allow access to the end of the cross-bar. Insert Endcap into the Cross-bar by locating the two 'feet' of the Endcap into the void inside the cross-bar (Fig 8). Push through until End-cap edge comes to rest against the edge of the cross-bar. This is important as the Locking Actuator inside the Endcap has to locate within the Locking slot on the end of the cross-bar. (Fig 9)

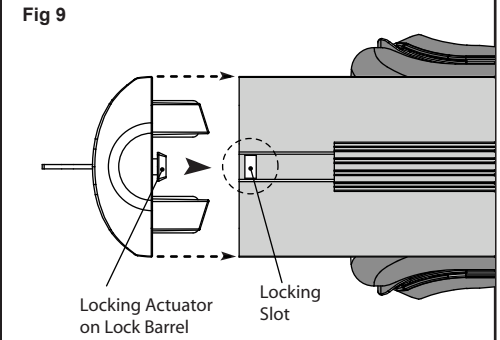
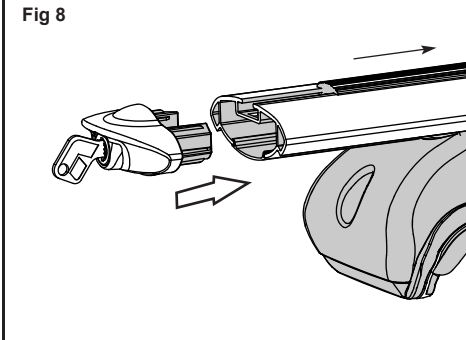

**Step 7**

Place the assembled Roof-racks back onto the vehicle's rails in the same position as initially measured against. (Fig 10) Ensure that both bars are parallel and square to the front and rear axis of the vehicle and that the metal straps have located correctly against the rails ensuring there is adequate 'cupping'. Using the Security Key provided, proceed to tighten the bolts whilst alternating sides to ensure even tension is achieved across the bars (Fig.11)

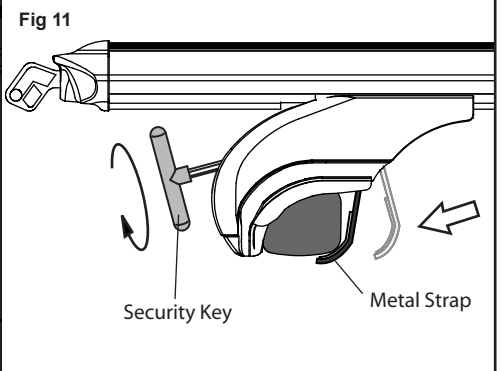
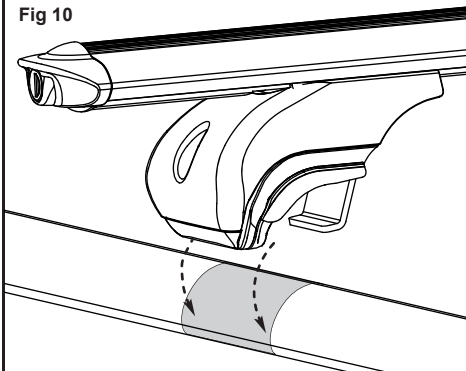

**Tip:** To ensure robust attachment, turn screw through 4-5 full revolutions after achieving a snug condition between the End Support & Inner Strap against the Rail bar (ie. 4-5 turns after eliminating all free-play in system)

**Final Check**

After loading the roof-racks, check the tightness of all bolts and ensure that the metal straps are positively engaged and tight up against the vehicle's rails.

Ensure the Endcap is locked against the Cross-bar by turning the key 90° anti-clockwise to the locked position. ( Fig.12)  
Store the keys in a safe location:  
eg. Car key chain or Glove compartment of vehicle.

Fig 12

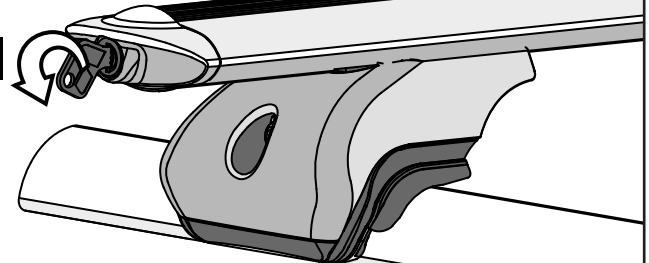
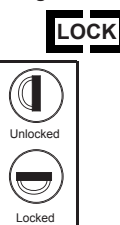

**USAGE INSTRUCTIONS**

It is essential for the proper assembly, operation and use of the Roof-rack that the instructions and safety precautions supplied are strictly observed. The Maximum permissible load for your Roof Bar is the lower of the maximum load capacity specified in your vehicle operation manual, or specified as applying to the Roof-rack. Do not exceed the maximum specified Load capacity.  
Maximum Permissible Load = Weight of the Roof-rack + Weight of Accessories + Weight of Load(Cargo).  
When fitting the Roof-rack and transporting a load, ensure the vehicle's functions are not impaired (eg. sunroof, aerials, windscreen wipers, mirrors). Rear doors on Hatch - and wagon-type vehicles should be inspected for adequate clearance for full opening operation of the boot/tailgate.  
Stop and check all screw connections, bolts and retaining straps after a short distance of travel. Repeat these checks at regular intervals.

**WARNINGS**

Remember that the fitting of a Roof-rack and the transport of a load increases the overall height of the carrying vehicle. Where the roof-rack is to be used in off-road conditions, a safety weight reduction of 1.5 should be observed from the total carrying capacity (eg. 60kg becomes 40kg). Cequent will not be liable to the purchaser of any other person for any consequential, direct or indirect loss, damage or costs incurred or suffered by the purchaser or any other person including but not limited to damage to persons or property, loss of turnover, loss of profits, loss of business or goodwill arising from or in relation to the assembly and use of the Roof-rack, or the non-observance of the fitting and care instructions.