



APEX & CAP Series Roof Racks
FORD TERRITORY WGN
MkI, MkII 04/04 on

PART No:

APEX/CAP018-2

FITTING INSTRUCTIONS:

CARRYING CAPACITY

80 kg (2 bars)
40 kg (1 bar)

COMMON		x4		x2		x4		x4		x4		x4		x4		x4		REPRESENTATIVE ONLY	x1	MOUNTS		x4		x4
	END SUPPORT		UNDER-COVER STRIP		SLUG NUT		FLAT WASHER		SPRING WASHER		M8 HEX NUT		M8 x 20 HEX BOLT		M6 x 30 STAR BOLT		ASSEMBLY KEY				TRACK PLATE		END SUPPORT BASE	

APEX		x4		x4		x2
	SPORTS CROSS-BAR END CAP		ROLA LOCK & KEY		SPORTS (RE GLOBAL) CROSS-BAR	

OR

CAP		x4		x2
	CROSS-BAR END CAP		HEAVY DUTY CROSS-BAR	

Please note volumes are halved for single bar kits

Please Note: You will require the following tools

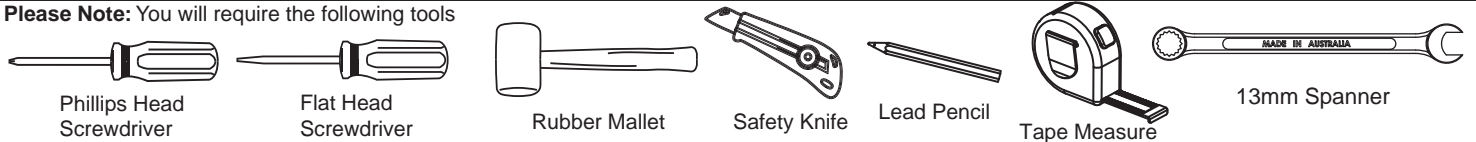

NOTE: Prior to Assembly

Prior to assembling, check that the kit contains all the parts you will need to fit the Roof Racks. Refer to the Parts List for guidance. Please read these fitting instructions prior to assembly.

STEP 1: Installing the Mounts

- Locate the factory track on your vehicle's roof containing 5 sets of anchor points (Fig. 1).
- Select 2 sets of anchor points and use an allen key to remove the factory countersunk screws from the threaded anchor point holes (Fig. 2).
- Place a 'track plate' in the factory track so the hole in the plate, lines up with the anchor point hole (Fig. 3).
- Place a 'end support base' on top of the 'track plate', so the centre slot lines up with the 'track plate' and anchor point holes (Fig. 3).
- Repeat this process on all 4 anchor point locations.

- Ensure that all parts are orientated correctly, lining up the holes with the anchor point.
- Keep the factory screws in a safe place.

Fig. 1

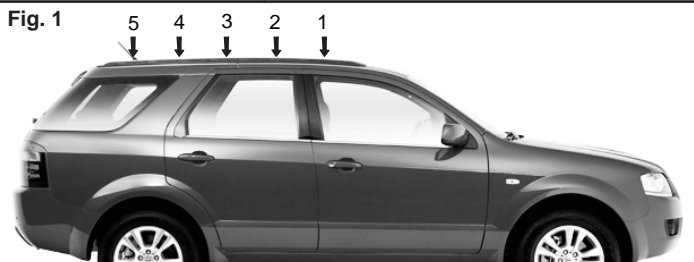

Fig. 2a

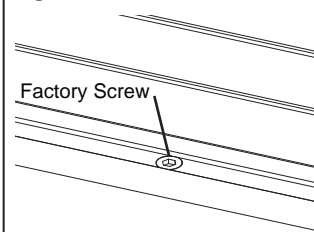

Fig. 2b

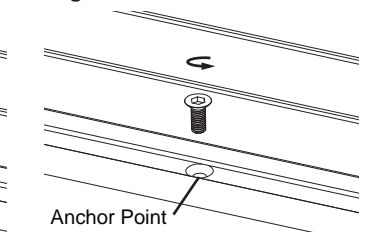

Fig. 3

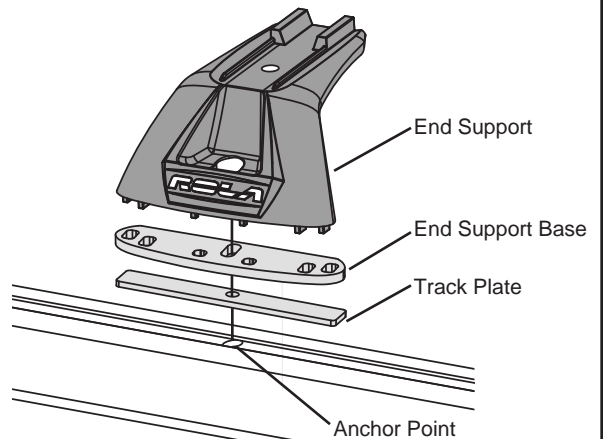
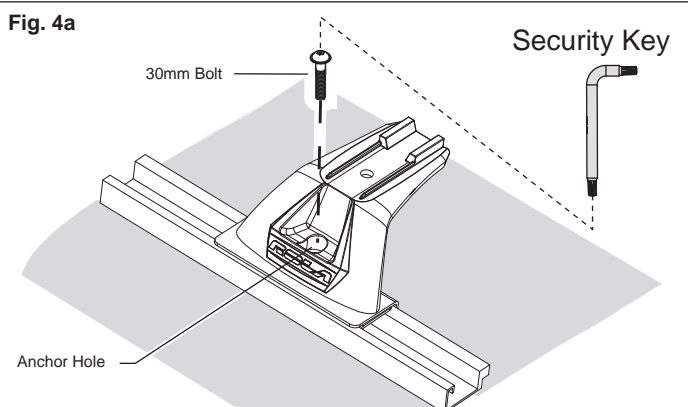

Fig. 4a



STEP 2: Fitting the Cross Bars to the Vehicle

- Place an end support onto the mounts from STEP 1, and loosely secure it down with a 30mm bolt by inserting the bolt through the end supports hole, the 'end support base' slot, the 'track plate' hole, and into the anchor point hole. Turn the security key approximately 2-3 turns (Fig. 4a). Do not tighten yet. Repeat for all mounts.

- B. Place the crossbar onto the end supports ensuring that the end supports are located into the cutouts on the underside of the crossbar. (Refer to Fig. 4b)
Check that the cross bar has equally distanced overhang on either side from the end support.
 - C. Insert the M8 nut into the cavity on the Commercial Slug. (Refer to Fig. 4c).
 - D. Insert the Commercial Slug into the cross tube, and align it so that the M8 nut in the Commercial Slug and the hole at the bottom of the end support line up. (Refer to Fig. 4c).
 - E. Secure the cross bar to the end support by screwing the M8x20mm bolt through the hole in the end support and up into the nut that is located in the cavity of the Commercial Slug. (Refer to Fig. 4c).
 - F. Tighten M8 bolts to 6-7 Nm
Tighten M6 bolts to 5-6 Nm
 - G. Repeat for all 4 end supports.
- Refer to fitting instruction 424 for insertion of the under-cover strip.

STEP 3: Inserting & locking the End Cap

- A. Pull back the buffer strip to allow access to the end of the cross-bar. Insert Endcap into the Cross-bar by locating the two 'feet' of the Endcap into the void inside the cross-bar. (Fig 5a)
- B. Push through until End-cap edge comes to rest against the edge of the cross-bar. This is important as the Locking Actuator inside the Endcap has to locate within the Locking slot on the end of the cross-bar.
- C. Ensure the Endcap is locked against the Cross-bar by turning the key 90° anti-clockwise to the locked position. (Fig.5 b)

STEP 4: Mounting your Accessories

- A. Remove the End Caps from the cross-bars.
Next, remove the buffer Strip from the Global Channel.
- B. Mount and fix your Accessories into position onto the cross-bars, utilizing the Global Channel.
Insert the Buffer Strip into the Channel and cut off the excess from around your accessory to prevent wind/water ingress.
- C. Re-Insert your Endcaps onto the ends of the cross-bars ensuring they are locked in place.
Store the keys in a safe location:
eg. Car key chain or Glove compartment of vehicle.

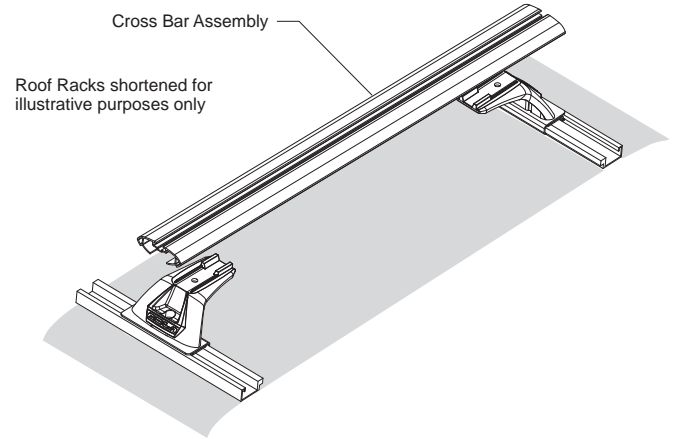
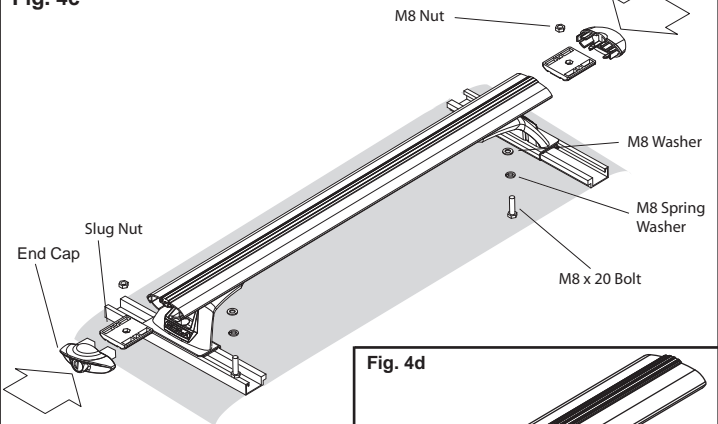
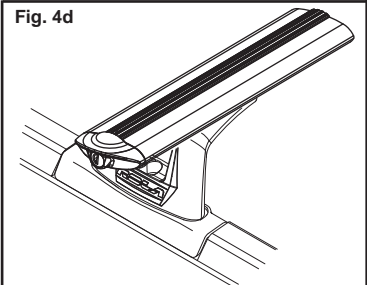
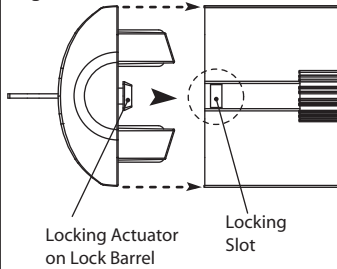
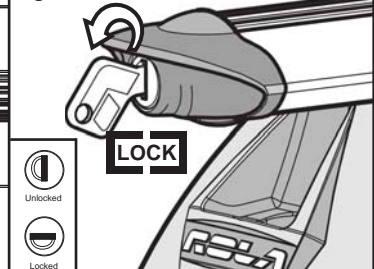
Fig. 4b

Fig. 4c

Fig. 4d

Fig. 5a

Fig. 5b

General Usage Information

- It is essential for the proper assembly, operation and use of the Roof Rack that the instructions and safety precautions supplied are strictly observed. Read any fitting, care and usage instruction carefully.
- The maximum permissible load for your Roof Bar is the lower of the maximum load capacity specified in your vehicle operation manual, or specified as applying to the Roof-Rack. Do not exceed the maximum specified load capacity.
- Maximum permissible load = weight of the Roof Rack + weight of accessories + weight of load (cargo).
- When fitting the Roof-Rack and transporting a load, ensure the vehicle's functions are not impaired (eg, sunroof, aerials, windscreen wipers, mirrors). Rear doors on Hatch- and Wagon-type vehicles should be inspected for adequate clearance for full opening operation of the boot/tailgate.
- Stop and check all screw connections, bolts and retaining straps after a short distance of travel. Repeat these checks at regular intervals.

Warnings

- Remember that the fitting of a Roof Rack and the transport of a load increases the overall height of the carrying vehicle.
- Where the Roof-Rack is to be used in off-road conditions, a safety weight reduction of 1.5 should be observed from the total carrying capacity. (eg. 60kg becomes 40kg)
- ROLA will not be liable to the purchaser or any other person for any consequential, incidental, direct or indirect loss, damage or costs incurred or suffered by the purchaser or any other person including but not limited to damage to persons or property, loss of turnover, loss of profits, loss of business or goodwill, arising from or in relation to the assembly and use of the Roof rack, or the non-observance of the fitting and care instructions.