

- ① - 2 x Cross-bars & Buffer Strips (Front & Rear)
- ② - 1 x Set of (4) -RBXL-Covers and Locks
- ③ - 4 x End Supports
- ④ - 1 x Top & Bottom Straps
- ⑤ - 1 x Small Parts & Hardware Kit

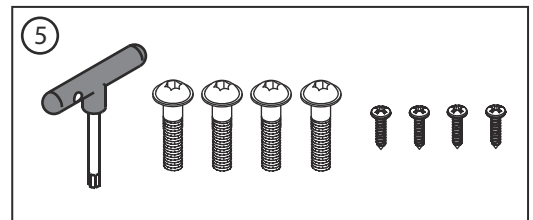

Please Note: You will require the following tools

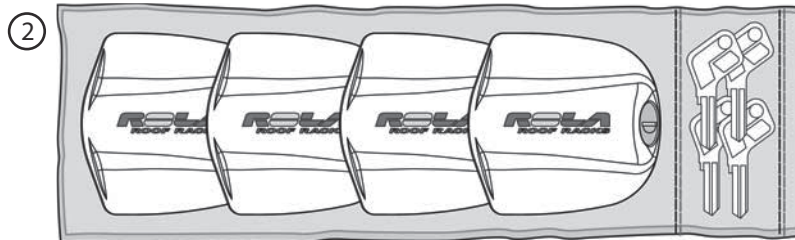
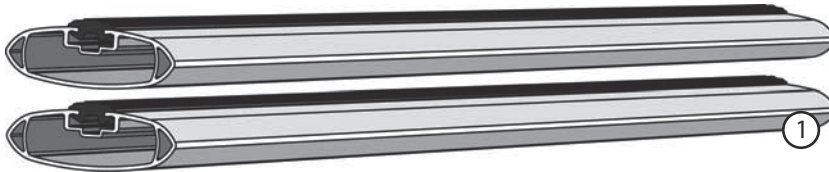
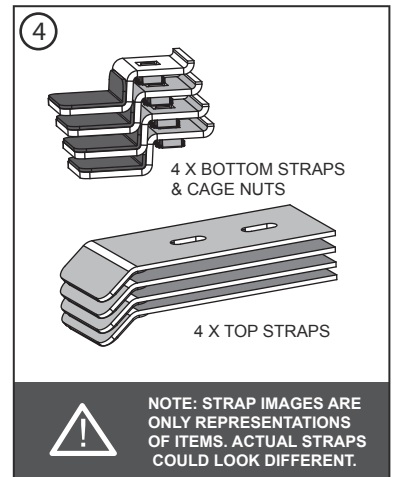
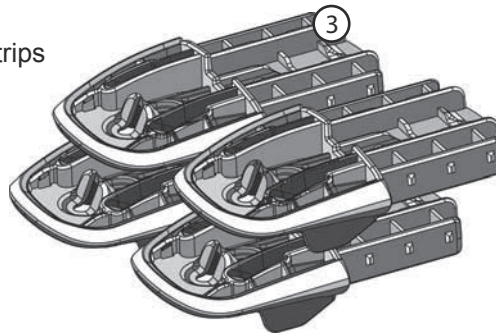
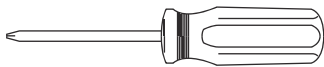

Phillips Head Screwdriver

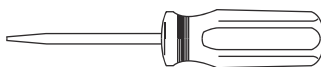

Flat Head Screwdriver

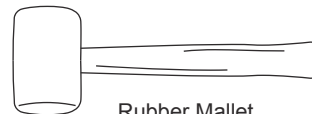

Rubber Mallet

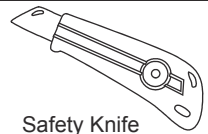

Safety Knife

Please check your roof-rack box to ensure you have received all components. Read these instructions thoroughly before commencing installation. (Please contact your dealer if your KIT is incomplete)

ASSEMBLY OF CROSS BARS

1. Ensure that the Rail Bars are clean; free from dust and grease.
2. Pre-assemble the End Supports into Cross Bars. They are designed to be a tight fit: Use a rubber mallet if necessary (Fig.1).
3. Slide Top Strap into End Support Chassis (as shown in Fig 2). Fit Star-Head Bolt through the slot closest to the curled end of the Top Strap. This will allow correct Strap alignment while fitting Screw in Step 4.
4. Push rubber Buffer Strip back about 20mm until you can see the screw hole in the cross bar. Using a Phillips head screw-driver, fasten the screw through the cross bar and into the End Support Chassis (Fig 3). Replace Buffer Strip.

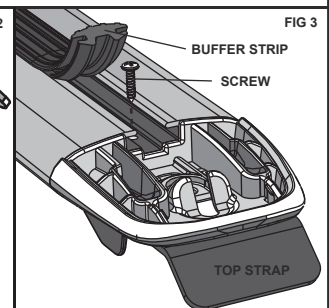
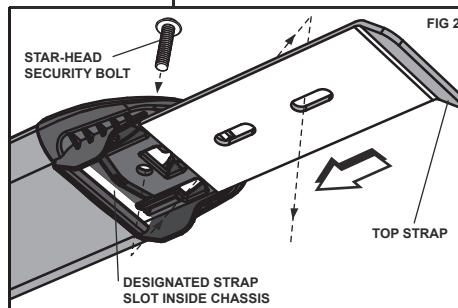
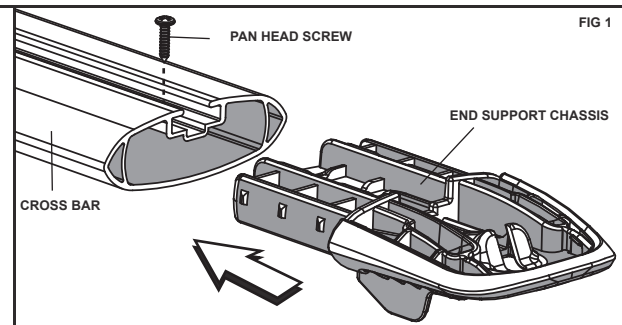

5. Place Cross Bars on the vehicle at the recommended positions shown along the Rail Bars (Fig. 4).

Pull the Top Strap out slightly (5 to 6 mm) to allow Cross Bars to fit onto the vehicle Rail Bars.

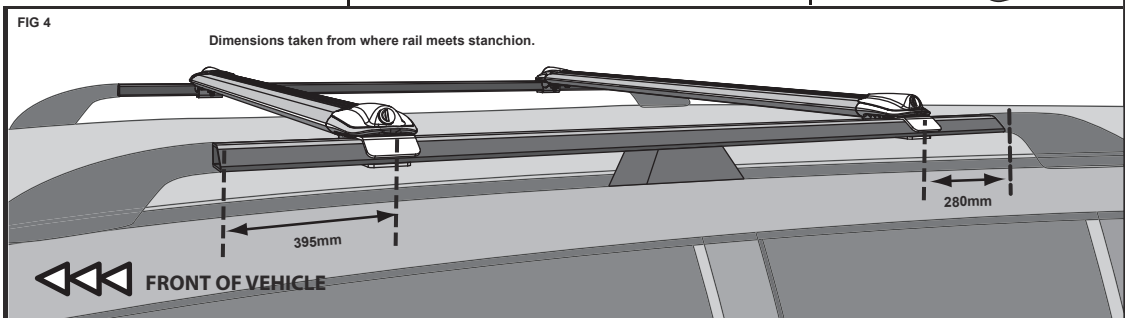

FITTING OF CROSS BARS TO VEHICLE

FIG 5

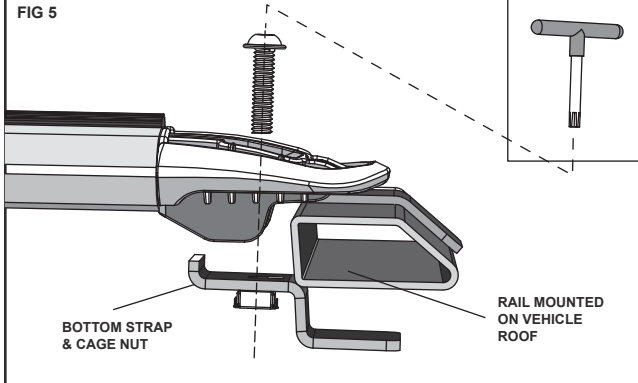
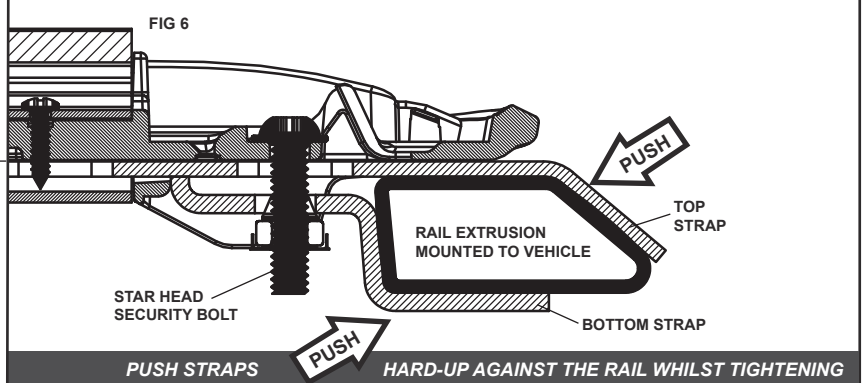

FIG 6



6. Place Bottom Strap under the Top Strap with the Tab facing inward and upward (Fig. 5). While holding the Bottom Strap in place loosely fit the Star Head Bolt with Key provided. Fit each corner in this manner. Check that the Cross Bars are centrally located between the vehicles Rail Bars.

7. Gradually tighten bolts alternatively ensuring Straps are properly engaged, until even tensioning is achieved. While tightening the Bolts pull the Bottom Strap out while pushing the Top Strap in. (Fig 6) **(Do not over-tighten bolts).**

FINAL CHECK BEFORE MOUNTING COVERS

Ensure that both crossbars are parallel to each other and that the straps are tightly mounted against the roof rail. Ensure that the bolts are tightened and that the crossbars are well secured. Perform a quick check by tugging on the crossbars back and forth.

FIG 7

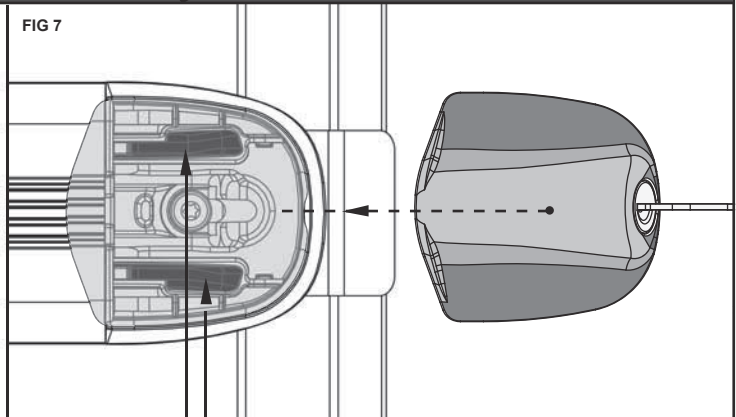
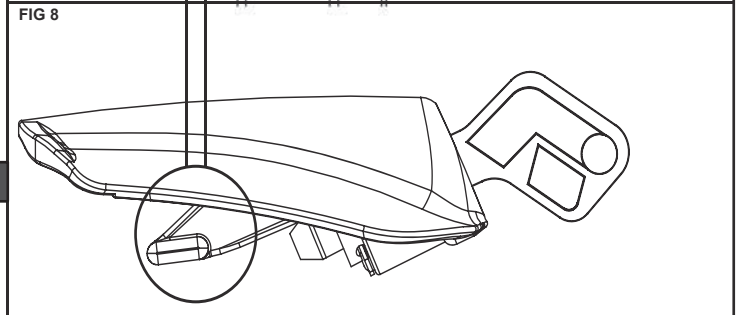

FIG 8



INSERTING COVERS

8. Remove covers from the roof rack kit. Locate the 2 ribs on the underside of the cover (Fig. 8). There are also two designated channels on the End Support Chassis into which these ribs locate. (Fig 7).

9. Insert the Cover into the End Support Chassis by sliding it through the channels until they positively engage into place and click. Do this for all 4 covers.

LOCKING AND REMOVING COVERS

10. Your cover keys should now be inserted into all 4 covers. With the keys in place, lock the cylinder by rotating 1/4 turn clockwise. (Fig 9) Repeat this process for all 4 covers. Please store the keys in a safe place, ie. with car Keys or in vehicle's glove compartment.

11. To remove the Covers, firmly grip the edge of the cover with your fingers (as shown by arrow ① in Fig. 10), and pull the cover towards you - (arrow ② in Fig. 10)

TIP: Ensure the covers are locked into place on the End Support when you store your roof-racks away.

FIG 9

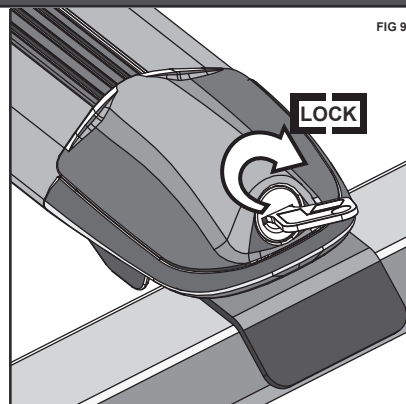
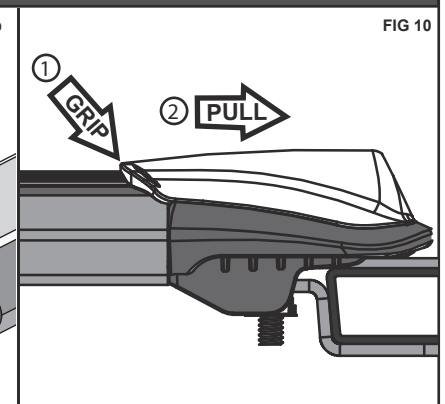



FIG 10



GENERAL USAGE INFORMATION

REGULARLY CHECK THE TIGHTNESS OF LOCKING STRAPS.

 Loads should be evenly distributed and secured. A number of accessories for carrying special loads is available. Only use NON-STRETCH tie down straps.

Any weight carried on the vehicle will adversely affect its handling particularly in cornering or in a cross wind and the vehicle should therefore be driven with increased caution.