

END SUPPORT (RIGHT) x2	END SUPPORT (LEFT) x2	MOUNT PAD (RIGHT) x2	MOUNT PAD (LEFT) x2	SNAP-ON COVER x4	SECURITY COVER x4	STRAP BRACKET x4	SCREW x4	SECURITY BOLT x4	SECURITY BOLT x4	ASSEMBLY KEY x1	CROSS-BAR ASSEMBLY x2

SOME FITMENTS MAY ALSO FEATURE THE FOLLOWING COMPONENTS:				
	ANCHOR POINT BOLT x4	ALLEN KEY x1	BOTTOM STRAP BRACKET x4	BOLT COVER x4

Please Note: You will require the following tools

Phillips Head Screwdriver	Flat Head Screwdriver	Rubber Mallet	Safety Knife

ASSEMBLY OF CROSS-BARS

1. Ensure the roof is clean, free from dust and grease.
2. Insert the neck of the End-Support into the void of the Cross-bar profile. They are designed to be a tight fit: use a rubber mallet if necessary (Fig.1)
3. Pull back the rubber Buffer Strip about 20mm until the screw hole can be accessed.(Fig. 2) Using a Phillips Head Screwdriver, fasten the screw through the cross-bar and into the End Support.
Do this for all four sides and replace the buffer strip.
NOTE: The longer cross-bars are to be fitted to the front of the vehicle. Check labelling on the underside of the cross-bar.

FITTING OF FRONT STRAPS TO VEHICLE

4. Open the vehicle doors and carefully pull back the weather seal to reveal the anchor points. Attach the front locking straps to the rearward anchor point using the shorter special bolts and washers (Fig. 4). Tension the special bolts and replace the weather seal.

FITTING OF REAR STRAPS TO VEHICLE

5. Carefully unclip the plastic covers from above the rear windows to reveal the rear anchor points.
6. Hook the rear locking straps over the most rearward anchor point. It may be necessary to flex the body panel outward to allow the strap to fit over the anchor point (Fig. 4). Either store the plastic covers in the vehicle glove box or modify them with a file to fit around the locking strap on refitted.

FITTING OF CROSS BARS TO VEHICLE

7. Place the rubber pads onto the vehicle roof wso that the cut out section fits under the locking strap.
NOTE: the pointier end of the rubber pads face towards the front of the vehicle (Fig. 4).
8. Place the appropriate crossbar assembly onto the rubber pads. The longer crossbar assembly is fitted to the front of the vehicle. Check labelling on the underside of the crossbars.

9. Loosely fit the special bolt through the end support and into the locking strap. Give two to three turns of the special bolt in the lokcing strap with the security key provided. Go to the other side of the vehicle and pull on the end support and fit the same. This will allow for correct alignment of the locking strap and the special bolt thread (Fig. 4).

PLEASE NOTE: When tightening the bolts, particular attention should be paid to the gap between the horizontal face of the strap and the underside of the end support. A gap of approximately 3 to 5mm should be left (Fig. 6). Overtightening of the bolts may result in roof damage.

10. Proceed to follow steps 4 to 9 when mounting the Rear Cross-bar Assy.

11. You are now ready to mount your "Accessories" set onto the cross-bars using the Global Mount Channel. Once installed, insert the 'Global Channel' Covers into the End Supports.

Note: You have a choice of 2 - (a) quick access snap-on cover or (b) long term mounting - security cover to cap off and lock the mount channel. (Fig. 7)

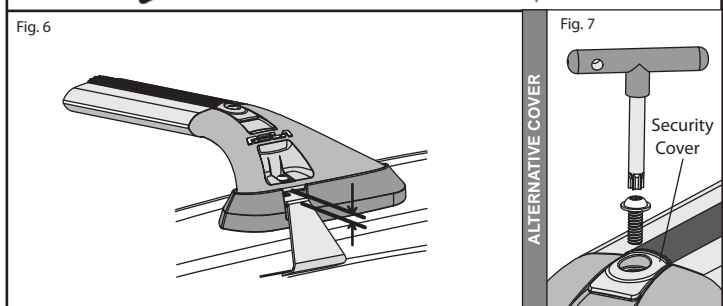
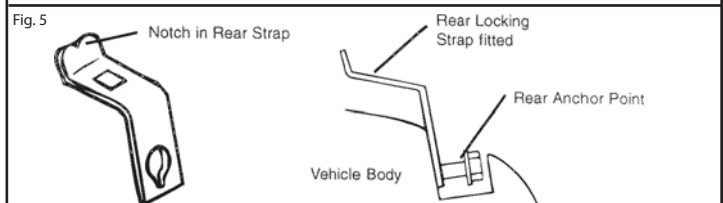
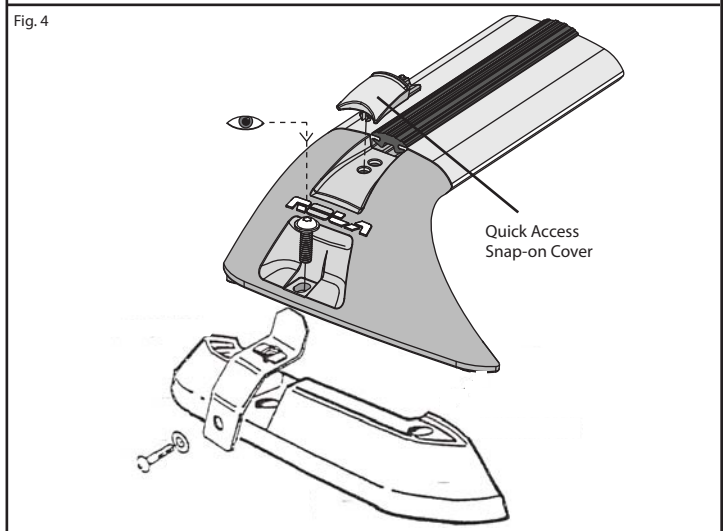
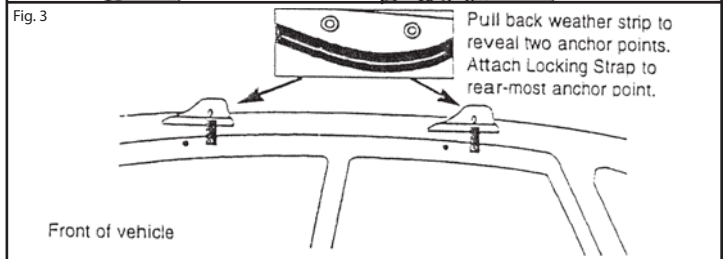
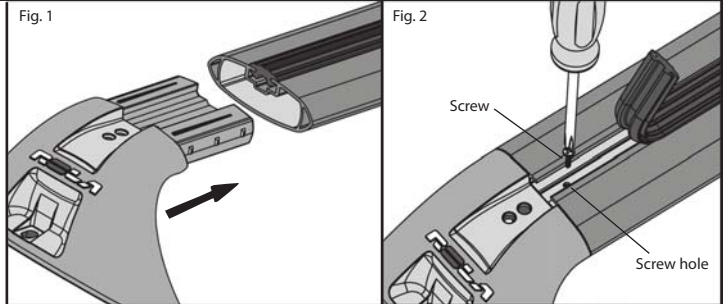

General Usage Information

It is essential for the proper assembly, operation and use of the Roof Rack that the instructions and safety precautions supplied are strictly observed. Read any fitting, care and usage instruction carefully.

The maximum permissible load for your Roof Bar is the lower of the maximum load capacity specified in your vehicle operation manual, or specified as applying to the Roof-Rack. Do not exceed the maximum specified load capacity.

Maximum permissible load = weight of the Roof Rack + weight of accessories + weight of load (cargo).

When fitting the Roof-Rack and transporting a load, ensure the vehicle's functions are not impaired (eg, sunroof, aerials, windscreen wipers, mirrors). Rear doors on Hatch- and Wagon-type vehicles should be inspected for adequate clearance for full opening operation of the boot/tailgate.

Stop and check all screw connections, bolts and retaining straps after a short distance of travel. Repeat these checks at regular intervals.

Warnings

Remember that the fitting of a Roof Rack and the transport of a load increases the overall height of the carrying vehicle.

Where the Roof-Rack is to be used in off-road conditions, a safety weight reduction of 1.5 should be observed from the total carrying capacity. (eg. 60kg becomes 40kg)

Cequent will not be liable to the purchaser or any other person for any consequential, incidental, direct or indirect loss, damage or costs incurred or suffered by the purchaser or any other person including but not limited to damage to persons or property, loss of turnover, loss of profits, loss of business or goodwill, arising from or in relation to the assembly and use of the Roof rack, or the non-observance of the fitting and care instructions.

APPENDICES & ADDITIONAL 'FITMENT SPECIFIC' FITTING STEPS - IF REQUIRED

This area has been intentionally left blank.