



LOW MOUNT

GWM TANK 300

LRS3034-FI
Revision A, June 2023

PACK CONTENTS & FITTING INSTRUCTIONS

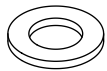

M8 FLAT WASHER
(22-0195)
x12



M8 SPRING WASHER
(22-0162)
x12



M8 HEX NUT
(22-0139)
x12



M8 T BOLT
(22-0961)
x12



M6 SECURITY BOLT
x12



TT27 SECURITY KEY
(22-0811)
x1

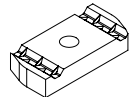

M6 CHANNEL NUT
(22-0564)
x12

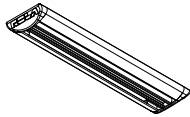

LOW MOUNT WITH END CAPS
x6 (25-0310 - 2 pack)
Each Low Mount contains
two end caps

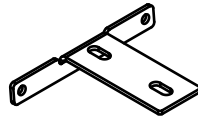

RAIL STRAP
x6

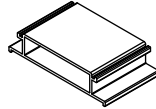

INTERCONNECTING BLOCK
(25-0312)
x3 for TFT1212, TFT1512 & TFT1812
x4 for TFT2014

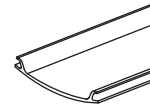

UNDER-COVER STRIP
x3
(32-0050)



RUBBER PAD
x6
(30-0030)

NOTE: Fasteners supplied with Titan Tray are required for this fitment.

1

Read instructions thoroughly before commencing installation.

Refer to Titan Tray instructions for tray assembly.

Skip to Step 5 on the following page if you have already inserted the interconnecting blocks.

3

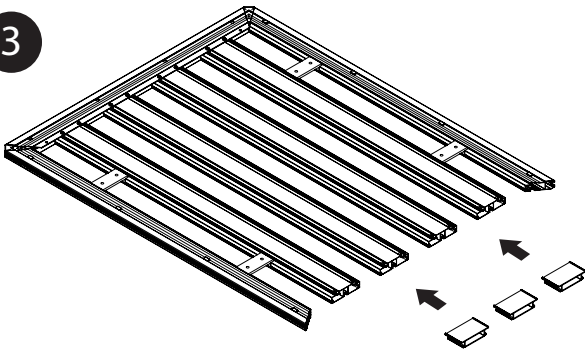

For TFT1212, TFT1512 & TFT1812:
Insert the three interconnecting blocks between the four centre planks.
Position interconnecting blocks in the centre of the tray.

For TFT2014:
Insert the four interconnecting blocks between the five centre planks.
Position interconnecting blocks in the centre of the tray.

2

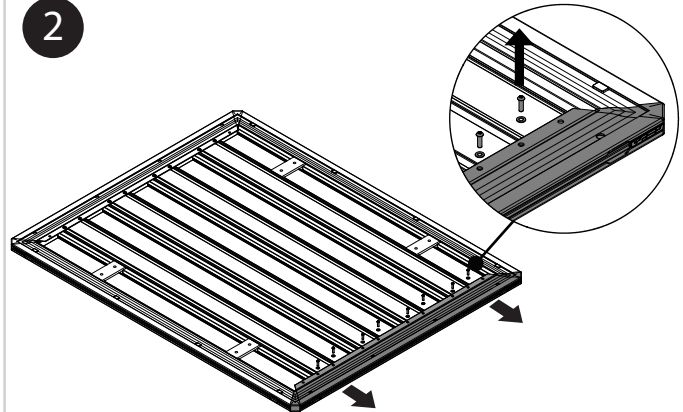

Place tray upside down. Remove fasteners on one side and remove the end plank.

4

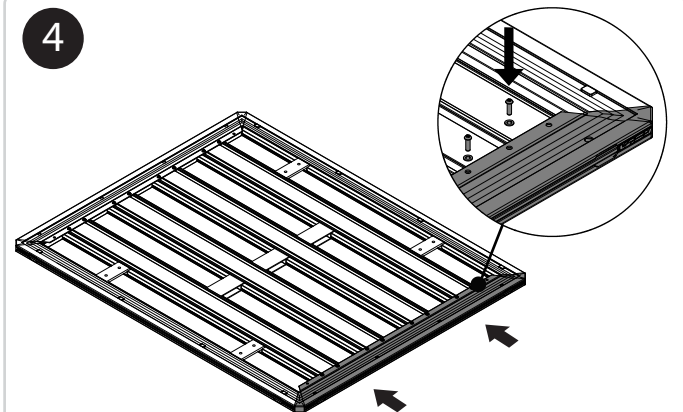

Re-install the end plank and fasteners.
Tighten fasteners securely.

LOW MOUNT SOLID RAIL

FITTING INSTRUCTIONS CONTINUED

ROLA

5

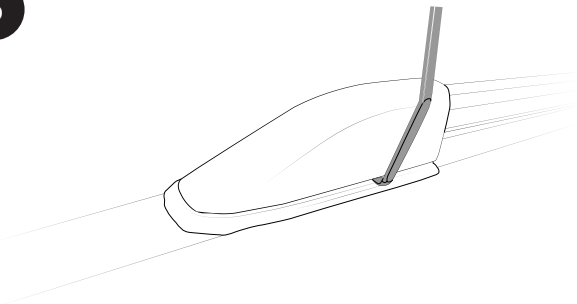

Using a plastic pry tool, remove the front cover of the rail

6

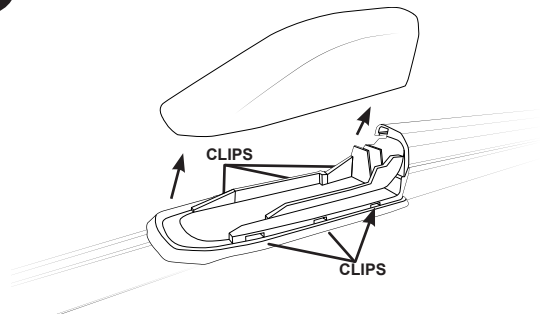

Tip: There are 6 clips in total

7

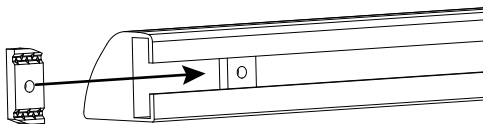

Slide four channel nuts into the exposed channel in the rail

8

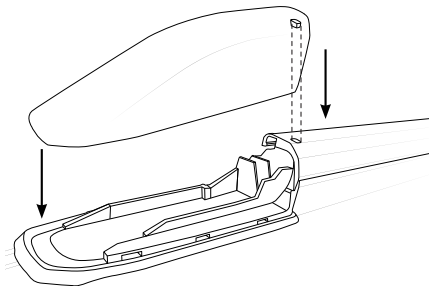

Replace the front cover, taking care to align the clips

9

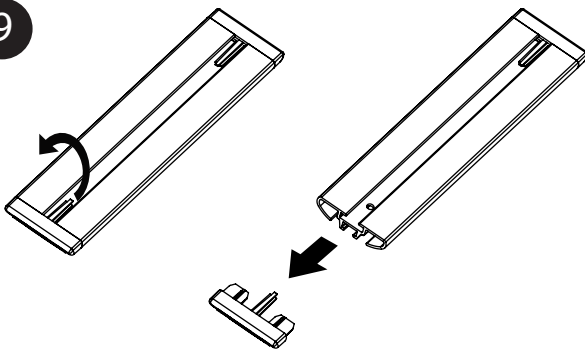

Unclip and remove one end cap from each of the Low Mounts.

10

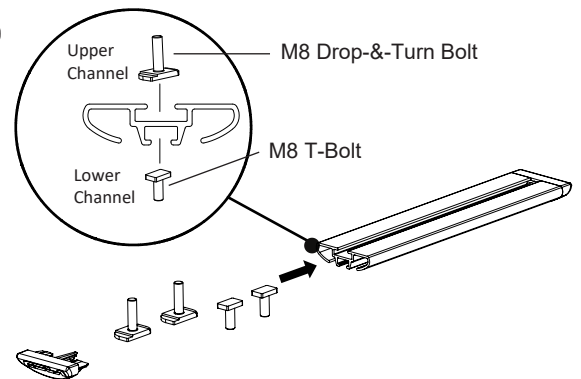

12

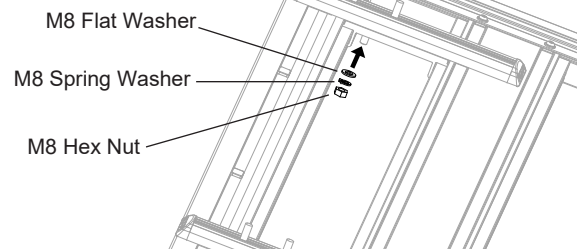

Thread fasteners on drop-&-turn bolts for all locations.
Tip: Leave loose to allow adjustment in next steps.

11

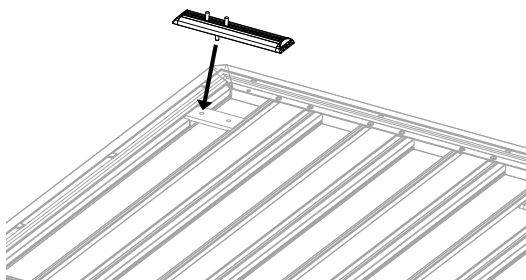

Tip: Work with tray upside down.

LOW MOUNT SOLID RAIL

FITTING INSTRUCTIONS CONTINUED



11

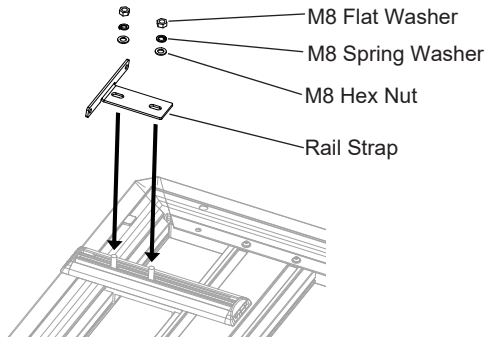

Thread fasteners on M8 Hex bolts for all locations.
Tip: Leave loose to allow adjustment in next steps.

12

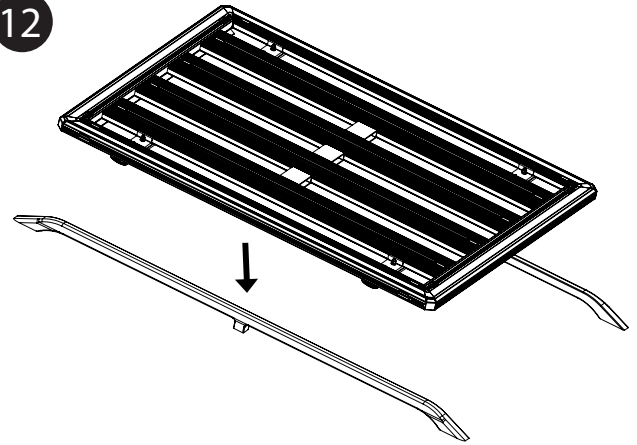

Lower tray onto roof rails

13

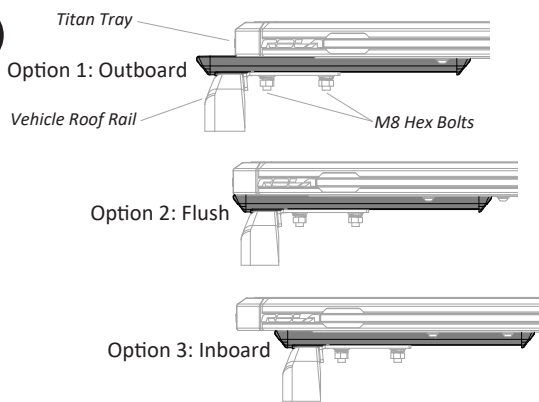

Slide the low mount to the desired width position.
 You can adjust the Low Mount to sit outboard, flush or inboard of the Titan Tray edge, depending on your preference and the distance between your vehicles roof rails.

14

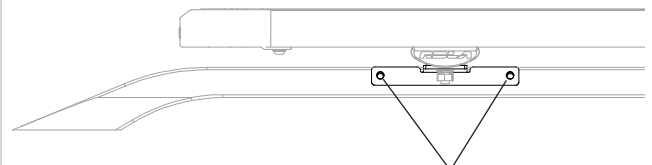

Align strap with channel nuts.

15

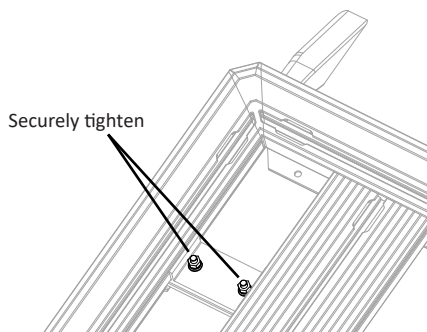

Tighten the fasteners on the top of the tray to secure the Low Mounts in place.

16

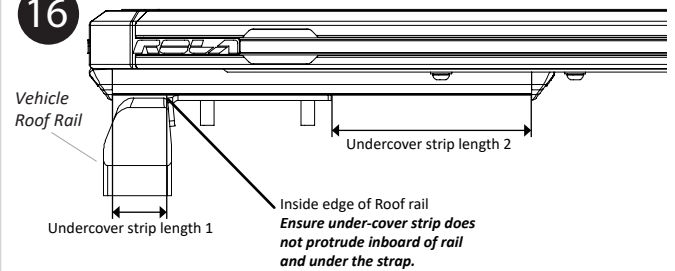

Cut the two lengths of under-cover strip for each Low Mount.
Tip: Measure the distance between the inside of the rail and the end cap while the tray is in the desired location on the vehicle roof rails.

17

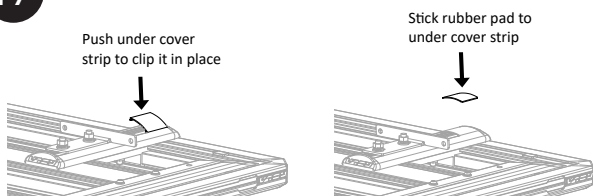

Insert undercover strip length 1 into Low Mounts.

Tip: Remove the tray and work with tray upside down.

18

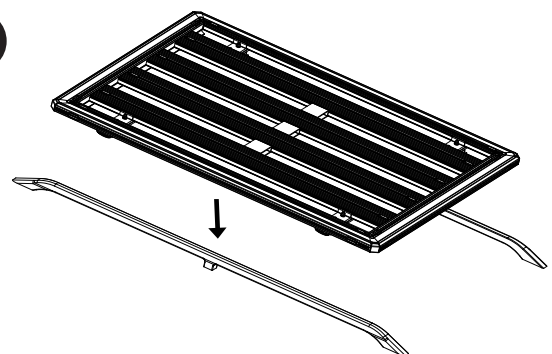

Lower tray onto roof rails

LOW MOUNT SOLID RAIL FITTING INSTRUCTIONS CONTINUED

ROLA

19

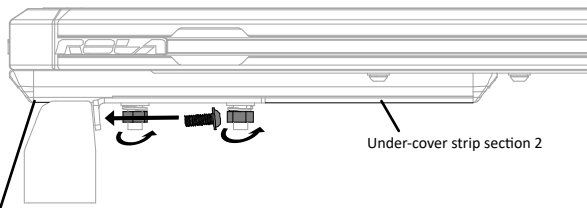

Locate under-cover strip section 1 with rubber pad to sit flush with end cap and ensure it does not protrude under the strap.
Insert the M6 Security bolt to the rail channel nuts and tighten with the TT27 security key.
Tighten the fasteners to clamp the strap to the Low Mount.
Attach the second section of under-cover strip.
Check all fasteners are tight.

20

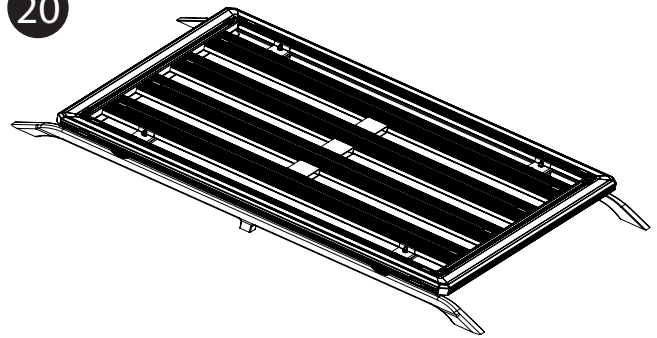

Your low mounted tray is now complete.

USAGE INSTRUCTIONS

It is essential for the proper assembly, operation and use of the roof-rack that the instructions and safety precautions supplied are strictly observed. The maximum permissible load for your roof rack or tray is the lower of the maximum load capacity specified in your vehicle operation manual, or specified as applying to the roof-rack or tray. Do not exceed the maximum specified load capacity.

Maximum permissible load = weight of the roof-rack and tray + weight of accessories + weight of cargo load.

When fitting the roof-rack and transporting a load, ensure the vehicle's functions are not impaired (e.g. sunroof, aerials, windscreen wipers, mirrors).

Hatch and wagon vehicles should be inspected for adequate clearance for full opening operation of the boot/tailgate.

Stop and check all screw connections, bolts and retaining straps after a short distance of travel. Repeat these checks at regular intervals.

WARNINGS

Remember that the fitting of a roof-rack and the transport of a load increases the overall height of the carrying vehicle.

Where the roof-rack is to be used in off-road conditions, a safety weight reduction of 1.5 should be observed from the total carrying capacity (e.g. 60kg becomes 40kg).

Roquent will not be liable to the purchaser or any other person for any consequential, direct or indirect loss, damage or costs incurred or suffered by the purchaser or any other person including but not limited to damage to persons or property, loss of turnover, loss of profits, loss of business or goodwill arising from or in relation to the assembly or use of the roof-rack, or the non-observance of the fitting and care instructions.