

RIDGE MOUNT

by **ROLA**[®]

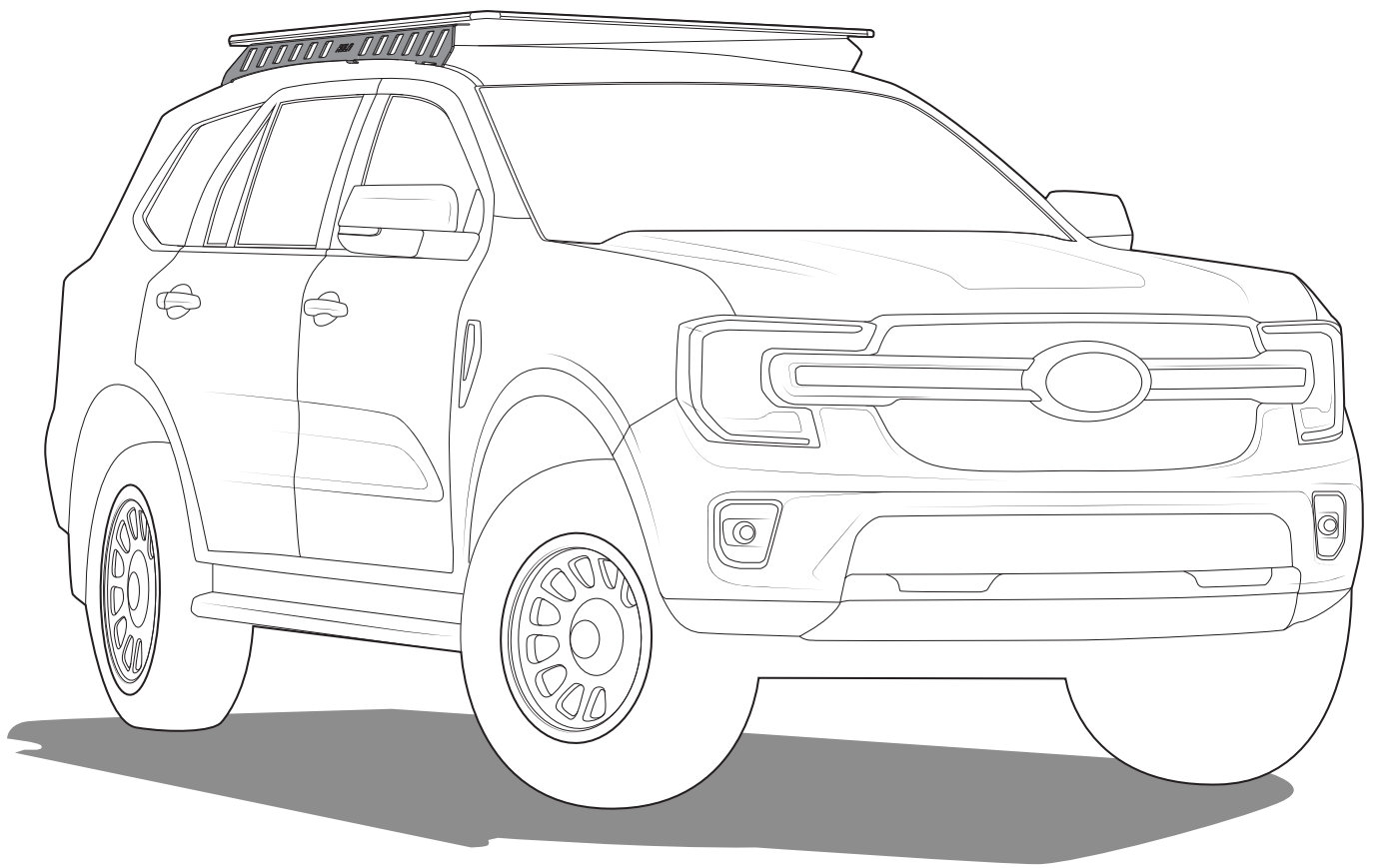

Read this full instruction prior to commencing assembly and fitment of Ridge Mount System.

CONTENT - CHECK ALL PARTS ARE CORRECT BEFORE PROCEEDING

A		Ridge Mount (pair)	1
B		Stud plate	6
C	<p>C1 : M6 x 16mm C2 : M6 x 20mm</p>	M6 Cap screw	C1 : 6 C2 : 2
D	<p>D1 : Plain Washer D2 : Black Washer</p>	M6 Flat washer	D1 : 8 D2 : 2
E		M8 Nyloc nut	12
F		M8x17mm Flat washer	36
G		M8x25mm Cap screw	12
H		Interlocking Block	3
I		M6 x 20mm button head screw	2
J		Ditch cover plate	2
K		Butyl patch	18
L		Rubber washer	2
M		M6 Hex Nut with Washer	10

TOOLS REQUIRED

- 5mm allen tool.
- 13mm, 10mm socket wrench.
- Step ladder.
- Clean cloth.

A

Move to the side of the vehicle. Use a step ladder to get access to the vehicle roof. This will be required at a later stage.

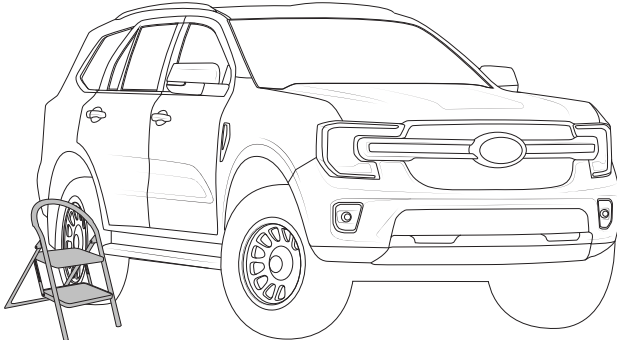

WARNING:

Disconnect battery before removing roof liner. To ensure all power has dissipated from the capacitors pump the brakes a few times and turn the lights on and off.

ROOF LINING REMOVAL instructions

1

Be sure battery is disconnected. Unscrew and remove the grab handles from the A-pillar.

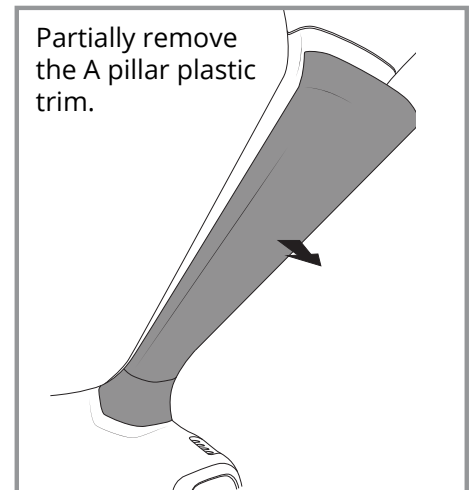
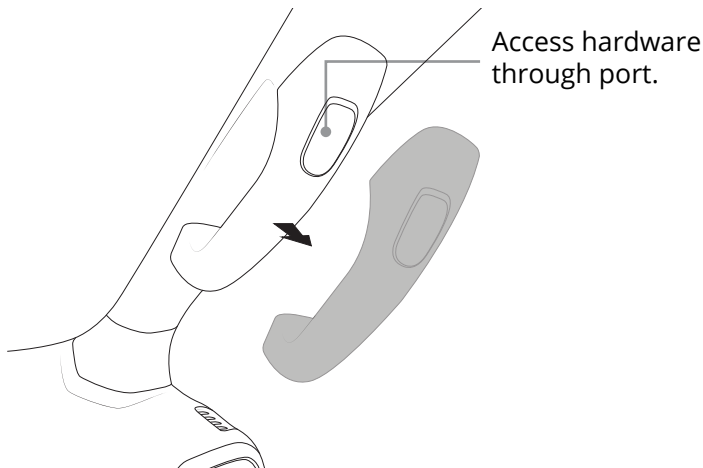

2

Remove the cover from the sun visor and unscrew the two screws, pull the sun visor down gently until you can reach the connector and unplug.

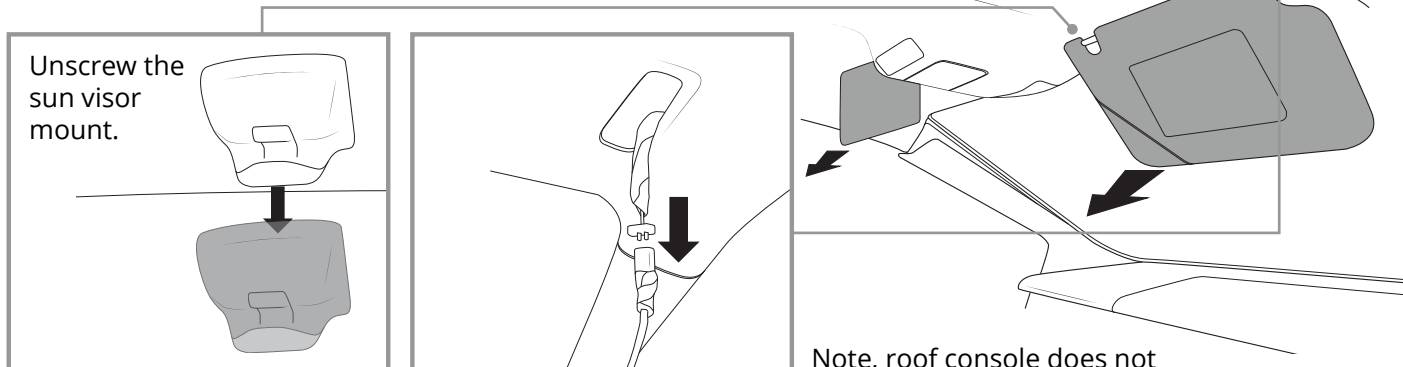

Note, roof console does not need to be removed.

3

Remove the top grab handle above the door.

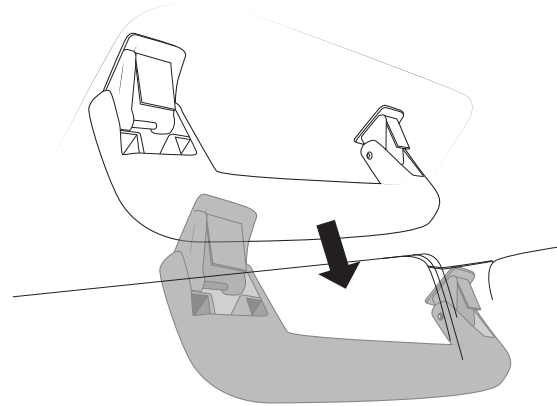

4

Unpeel the rubber door trim so that the top trims are exposed (approx. 50% from the top portion of the vehicle).

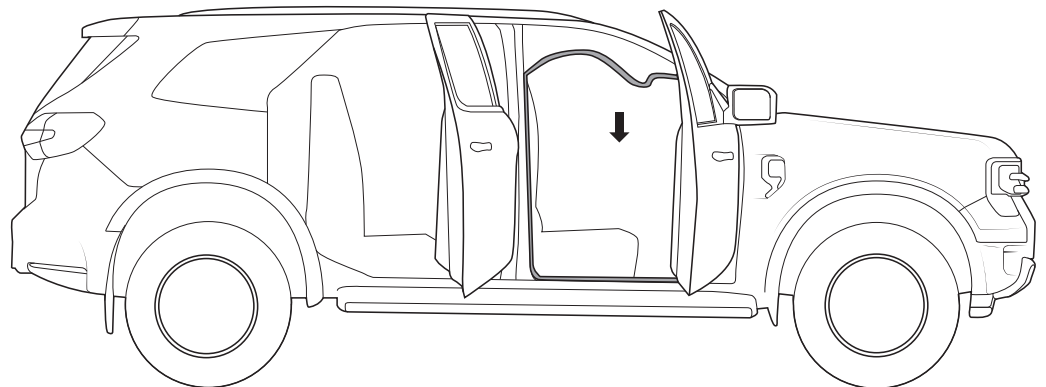

5

Move the seat back and recline for best access (don't do this if the seats are powered). Unscrew the seat belt (T50) torx.

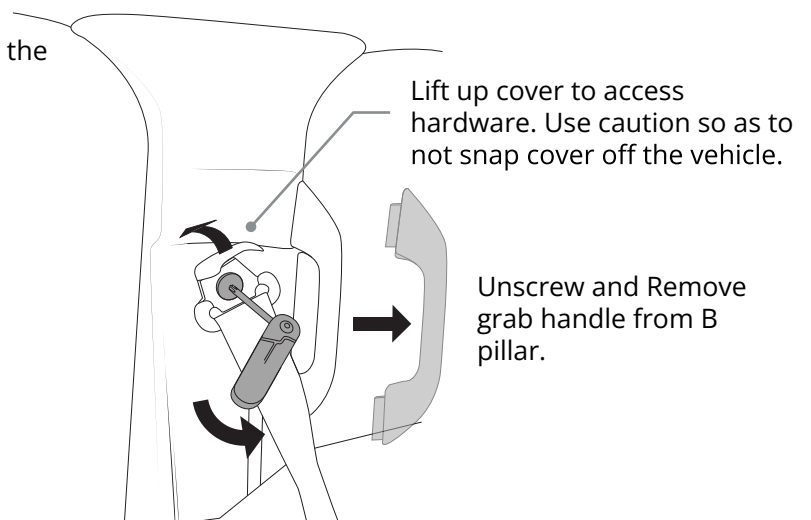

6

Grip the lower B pillar trim and gently pull it away from the wall. Gently remove the top B pillar trim making note of any clips that may fall off.

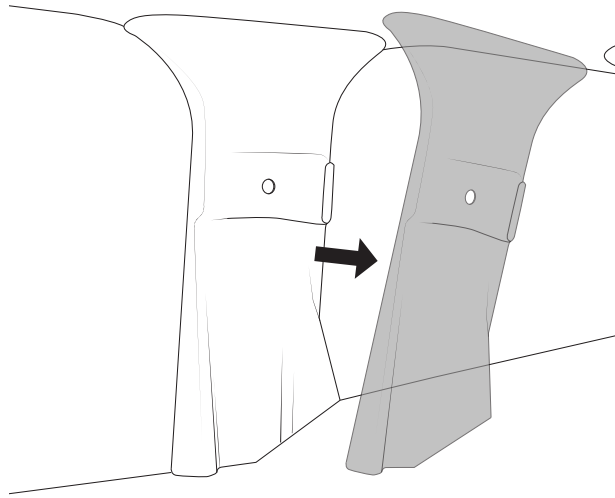

7

Unscrew and Remove grab handle from B pillar.

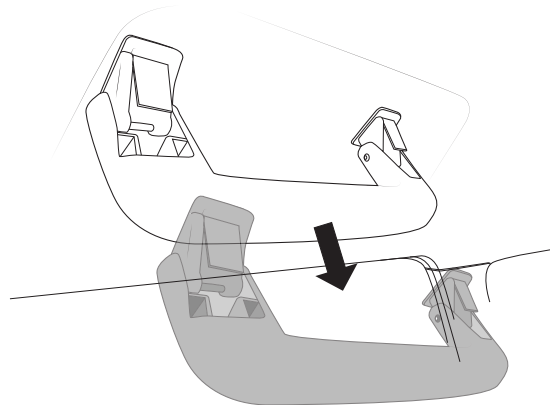

8

Unpeel the rubber door trim so that the top trims are exposed (approx. 50% from the top portion of the vehicle).

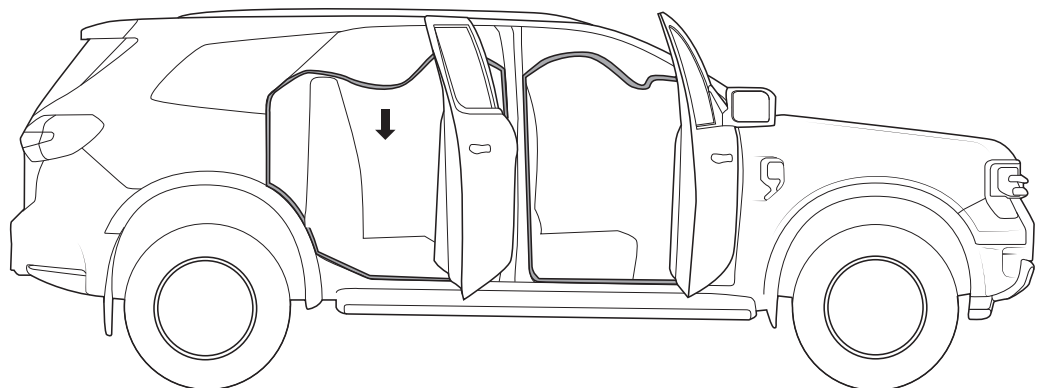

9

Unscrew the seat belt for the rear seat. Repeat previous steps on the opposite side of the vehicle.

10

Move rear seats forward to gain access to the rear of the vehicle from the back doors. Locate the low mounted rings, unscrew the torx bolts that retain them. Remove screw covers located directly behind the second row of seats. 20) Unscrew the 3rd row seatbelt.

11

Unscrew the rear roof hooks.

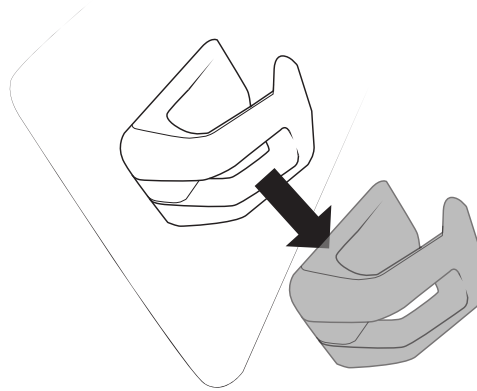

12

Unscrew the "tie downs" from the rear of the vehicle, accessed from the boot.

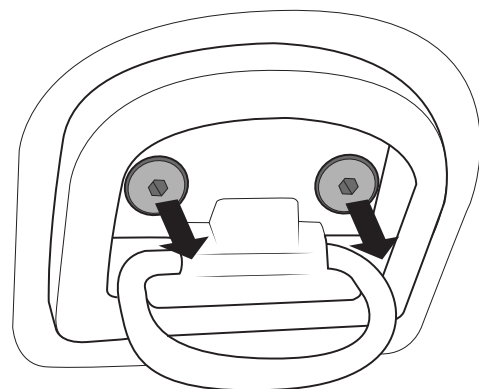

13

Grip the rear lower trim and gently pull towards the centre of the vehicle. Partially disconnecting it from the walls. Remove the upper trims making note to not lose any clips.

14

Once all the trims and screws have been removed, begin to gently pull down on the roof lining from the boot of the car, the roof lining is affixed by magnets and when you gently apply pressure it will disconnect and should provide enough access to the roof.

Not: the front of the roof lining will not lower, the camera and glasses box does not need to be removed for this task.

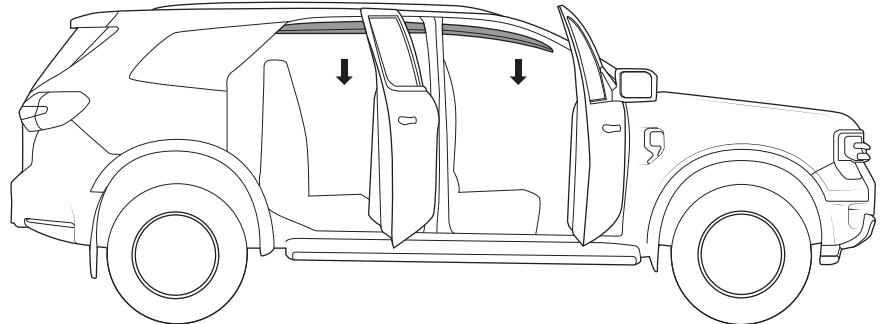

15

RHS only, unscrew the two screws holding the aircon duct in place.

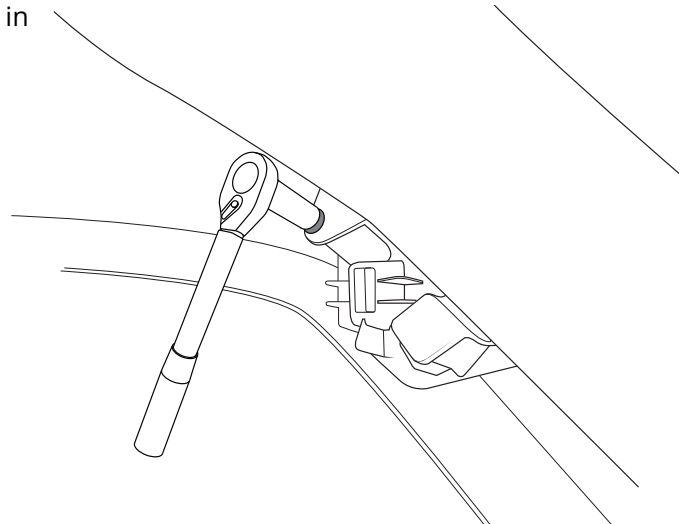

16

Unscrew the airbag bracket impeding the aircon duct.

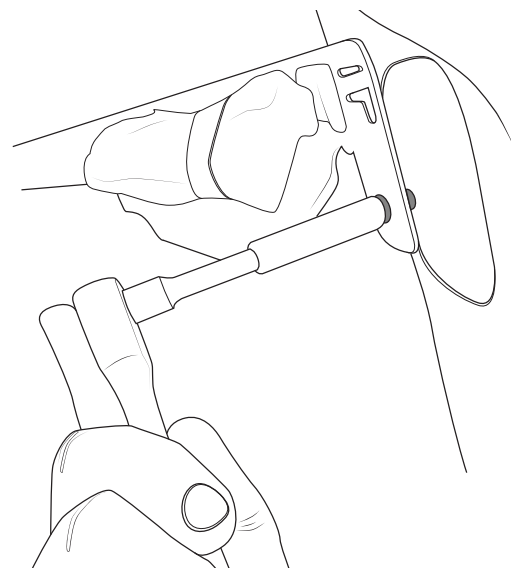

SYSTEM INSTALL

1

With the hood lining down, the factory rail mount hardware can be accessed. Remove the 5 factory nuts per side of the vehicle. Use a 10mm socket.

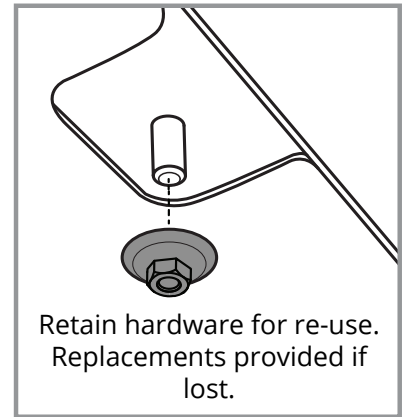
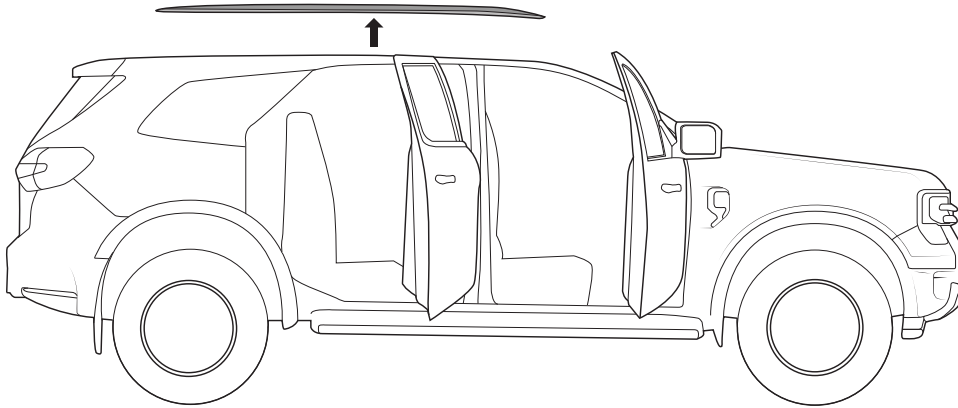

2

Clean the ditch where the factory rails have been removed.

(A) Using butyl mastic, apply the sealant to all exposed holes in the roof.

(B) Add 2x butyl patches to the exposed threads in the roof. **Apply only one patch to the front most hole.**

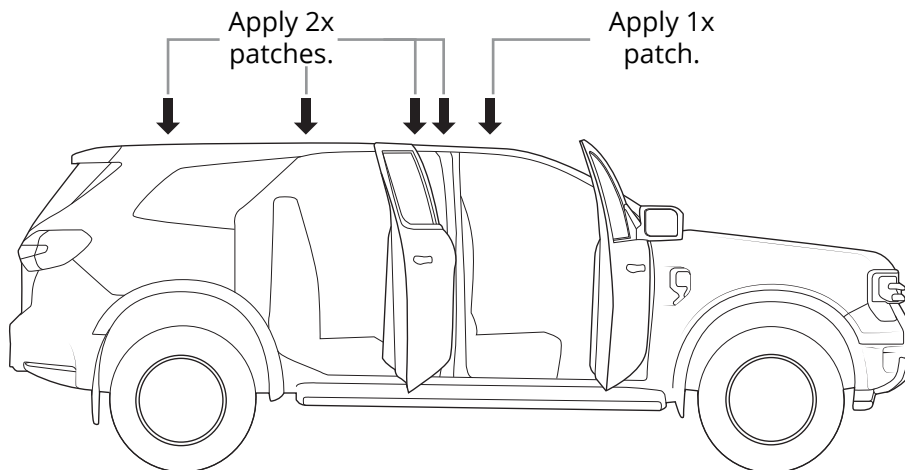
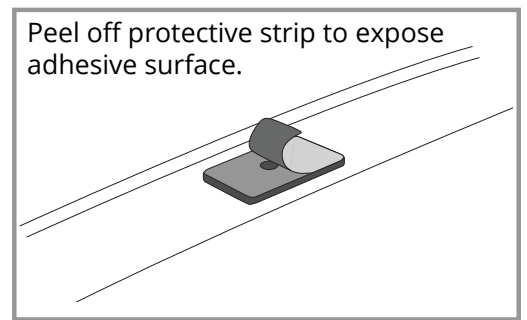
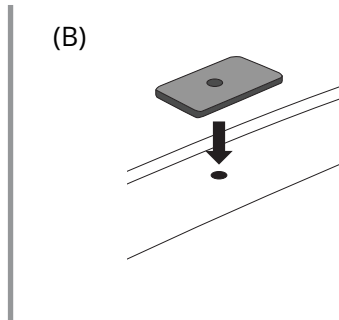
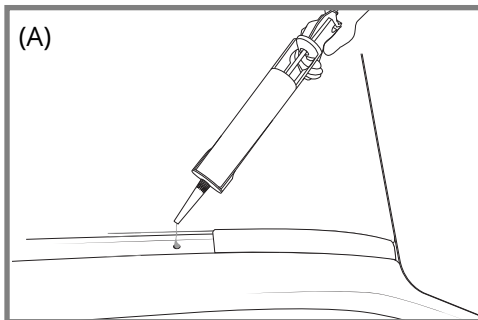

3

Install the kit provided M6 hardware into each rail. Note the front mount is left open at this stage.

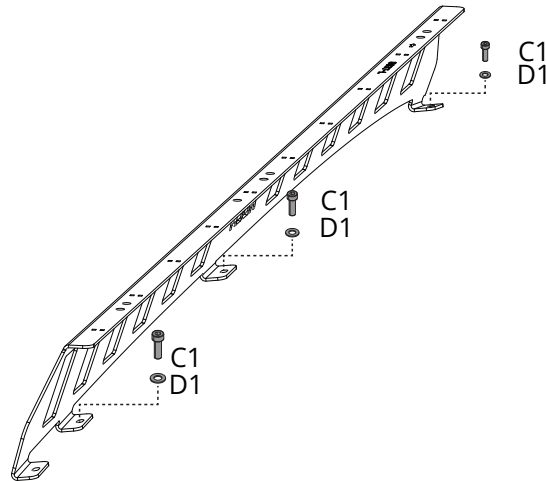

4

Install the stud plates as shown. Tighten with a 13mm socket.

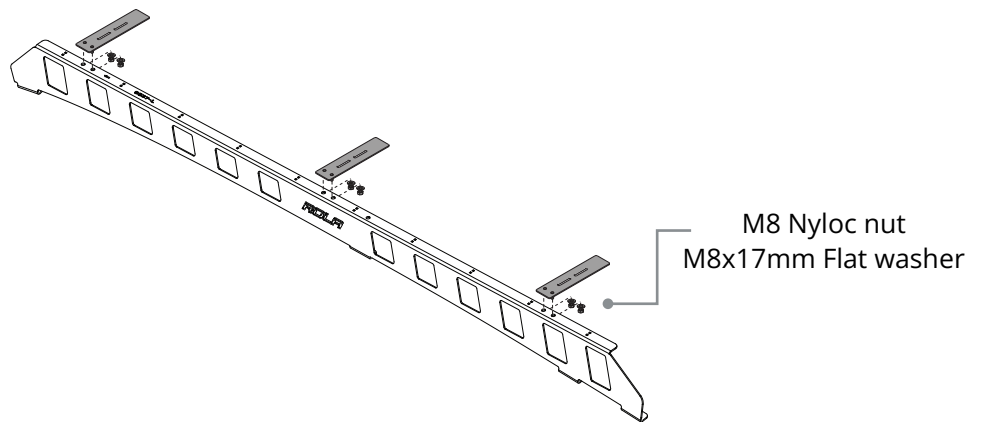

5

Place the rails onto the roof of the vehicle.

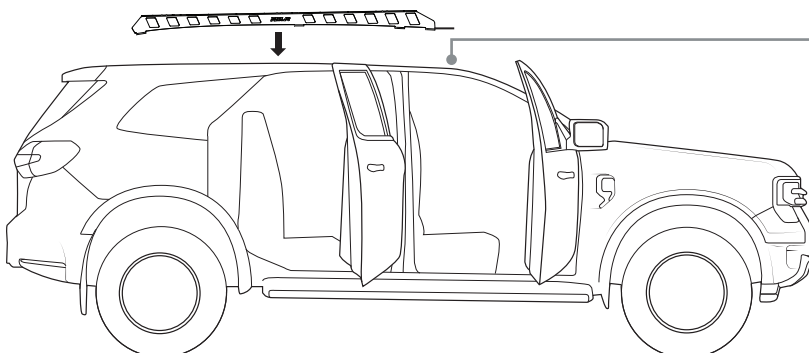

Install the ditch cover at the front of the vehicle at this stage.

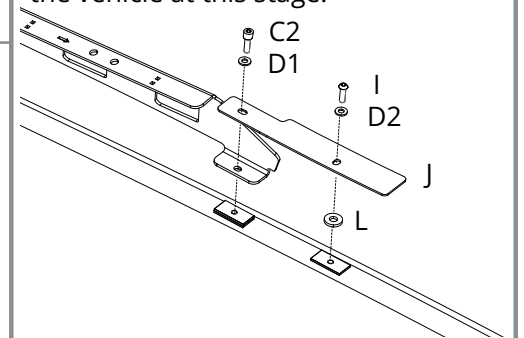

6

Tighten the M6 hardware with a 5mm allen key to 4-5Nm. The factory nuts will secure the M6 hardware from inside the vehicle.

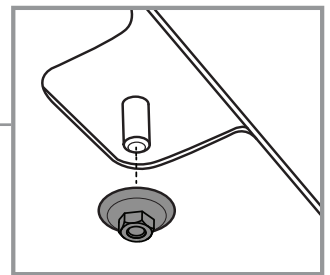
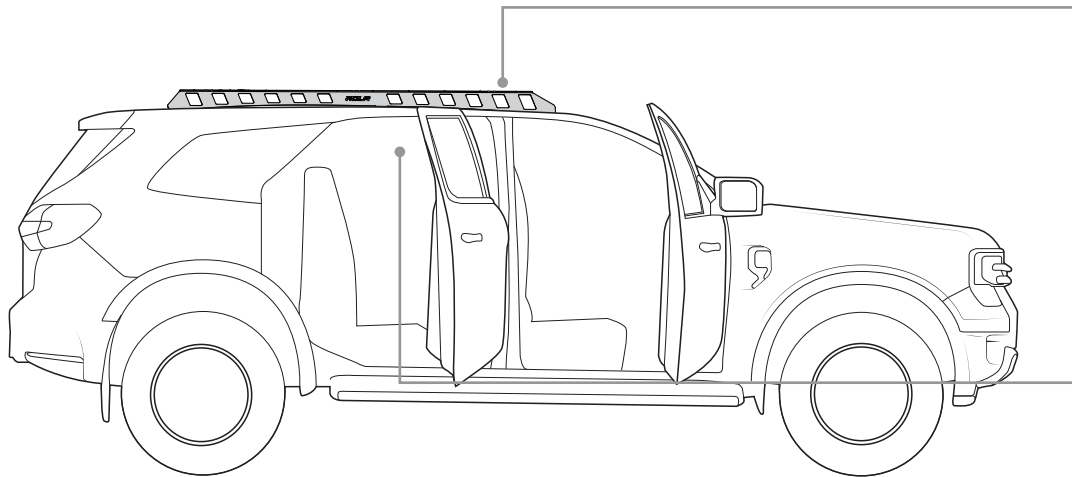

7

Replace the roof liner, using the liner removal steps in reverse order.

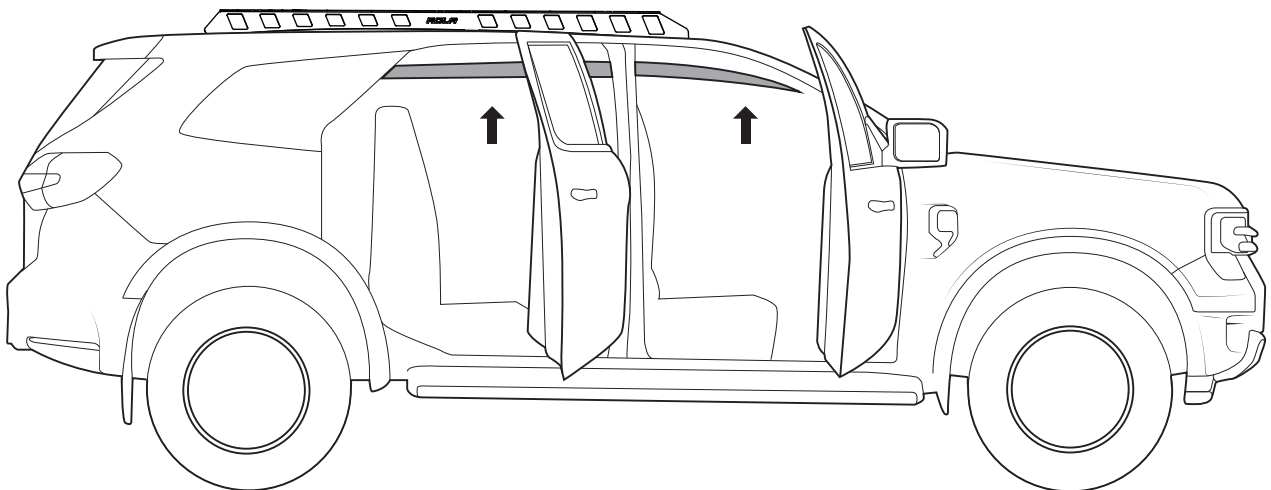

TITAN TRAY FITMENT - as per Titan Tray instructions

8

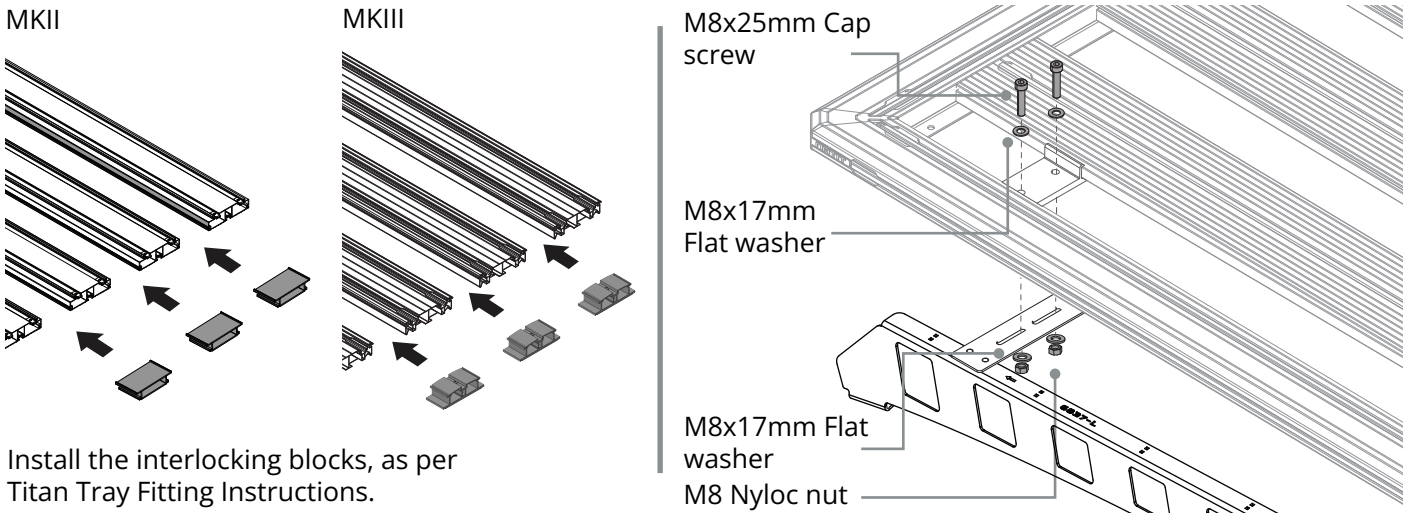

Install the interlocking blocks, as per Titan Tray Fitting Instructions.

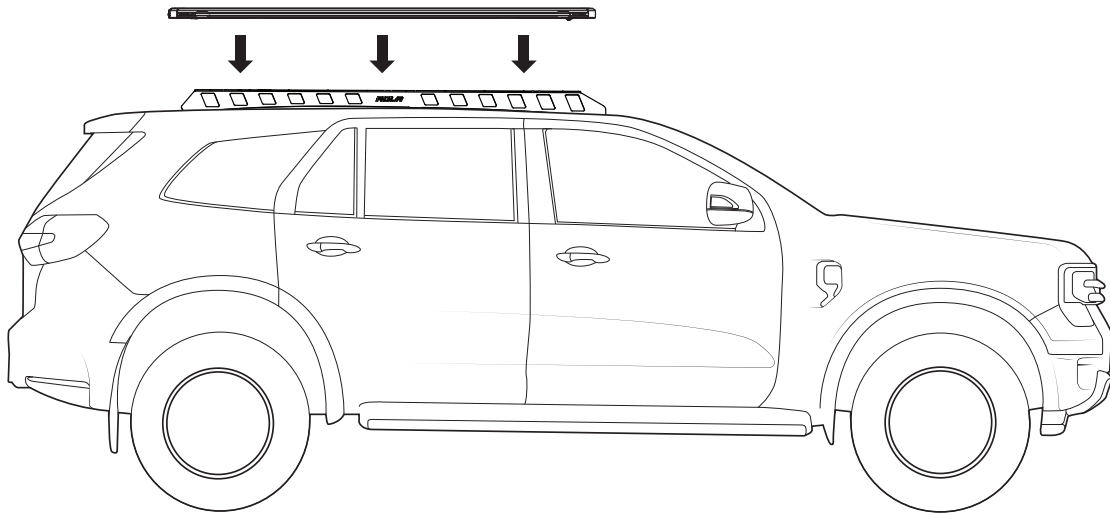

Note:

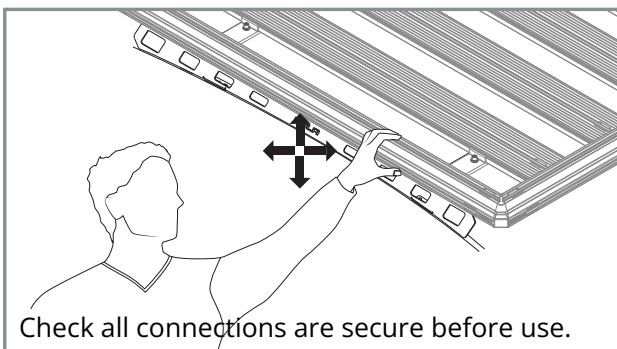

Wiring can be run and secured on the underside of the Ridge Mount rail as shown.

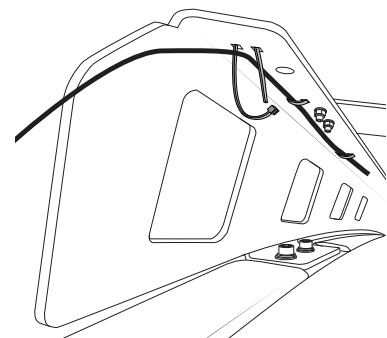

IMPORTANT - READ BEFORE USE

Please ensure the system is fitted in accordance with the fitting instructions. It is important that you observe all outlined below.

**LOAD RECOMMENDATIONS**

- Routinely and regularly check the proper functioning of the system. Check all fixtures at regular intervals.
- Do not use an automatic carwash with system installed.
- Maximum load capacity of the system is 300kg under static conditions.
- Maximum load capacity of the system is 100kg under dynamic including off-road conditions.
- Do not exceed vehicle manufacturers recommended load rating if it is lower than the maximum load capacity specified in this document (i.e., 100kg).
- Ensure any load carried is evenly distributed.
- Actual load on vehicle Roof (Refer to owner's manual) = Weight of Roof rack system / Ridge Mount + Weight of Tray + Weight of cargo.
- Actual load on rack system (Refer to product instructions) = Tray weight + cargo.

WARRANTY INFORMATION

Rola warrants that, subject to exclusions and limitations below, the Ridge Mount system will be free from defects in materials and workmanship for a period of 5 years commencing on the date of sale by the authorized Rola stockist to the original purchaser of the system.

If a defect appears in the Ridge Mount system before the end of the warranty period and Rola finds that the defect is in materials or workmanship, Rola will, in its sole discretion, either:

1. Repair the Ridge Mount or the defective component of the Ridge Mount system free of charge
2. Replace the Ridge Mounts or the defective component of the Ridge Mount system; or
3. Refund the purchase price of the Ridge Mount system to the original purchaser.

Rola reserves the right to change the design, specifications or composition of the Ridge Mount system without notice and without liability.

Rola reserves the right to replace defective products or components with products or components of similar quality, grade and composition, where an identical product or component is not available. Goods presented for repair may be replaced by refurbished goods of the same type rather than being repaired. Refurbished parts may be used to repair the goods.

The 5 year warranty does not apply where:

1. The Ridge Mount system is not installed in compliance with the fitting instructions provided
2. The Ridge Mount system is not used as intended or designed
3. Any part of the Ridge Mount system is used with other products or components not intended to be used in conjunction with the Ridge Mount system
4. The Ridge Mount system has been on-sold or assigned by the original purchaser
5. The Ridge Mount system has been modified or repaired by someone other than Rola or an authorized Rola stockist
6. Rola cannot establish any fault after inspection of returned product
7. The Ridge Mount system has been subject to abnormal conditions, including fire, water, humidity, pressure, stress or similar
8. The defect in the Ridge Mount system has arisen due to abuse, misuse, neglect or accident
9. The defect in the Ridge Mount system has arisen due to the unlawful or unusual operation of the vehicle to which it is fitted
10. The defect in the Ridge Mount system has arisen due to the purchaser's failure to properly assemble, install, fit, maintain or use the Ridge Mount system in accordance with the specifications and instructions provided by Rola.

For safety and use instructions, please refer to any General or Specific Fitting Instructions and Warning & Care Instructions enclosed within the Ridge Mount system or on our website at www.rola.com.au.

This warranty does not extend to fair wear and tear. Warranty claims can be made by contacting Rola directly using the details below. A warranty claim must be accompanied by proof of purchase (such as receipt), details of the alleged defect and appropriate documentation (such as historical and maintenance records where appropriate). The customer must make the product available to Rola or its authorized repair agent for inspection and testing. If such inspection and testing finds no defect in the product, the customer must pay Rola usual costs of service work and testing. It is the purchaser's responsibility to arrange and pay to return the product or component to the place of purchase. The purchaser may seek reimbursement from Rola for the cost of such activities, providing Rola notifies the purchaser in writing that a warranty claim is justified. Any such claims made must be in writing via post or email.

The benefits of this warranty are in addition to any rights and remedies imposed by Australian State and Federal legislation that cannot be executed. Nothing in this warranty is to be interpreted as excluding, restricting or modifying any State or Federal legislation applicable to the supply of goods and services which cannot be so excluded, restricted or modified. Our goods come with guarantees that cannot be excluded under the Australian Consumer Law. You are entitled to a replacement or refund for a major failure and for compensation for any other reasonably foreseeable loss or damage. You are also entitled to have the goods repaired or replaced if the goods fail to be of acceptable quality and the failure does not amount to a major failure. Rola makes no express warranties or representations other than set out in this warranty.