

# FITTING INSTRUCTIONS: TIE DOWN ATTACHMENT

Product Code Number:

TDA

Fitting Instruction Sheet No.

140

ISSUE B  
09/03/04

Tie Down Attachment Fitting Kit Includes:

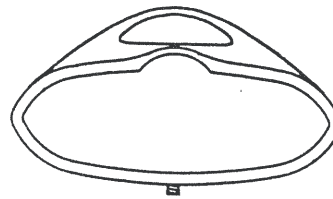

Tie Down Attachment x 4

The procedure listed below in parts one and two is the same for all ROLA cross bars and end supports.

1. Remove cross bars from vehicle. On one side of the cross bar only push the rubber Buffer Strip back about 20mm until the phillips head screw appears. Remove the screw using a phillips head screw driver. Place the screw in a safe place as it will be required for re-fitting.

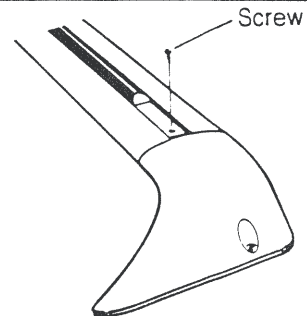

2. Remove the end support from cross bar. The end support is designed to be a tight fit; a light tap with a rubber mallet may be required for removing and re-fitting the end support.

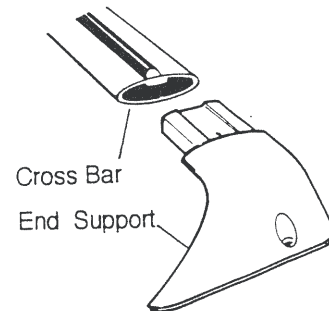

3. Slide tie down attachments to desired position on cross bars. Secure attachments by tightening screws with allen key supplied. Occasionally check screw tightness. Reverse the above procedure to re-fit the cross bars to vehicle.

