

Parts List: (Refer to Fig.1)

Item	Description	Qty.	Part No.
1	Cross Bars (with Buffer Strip)	2 (1)	EX1150B
2	End Support	4 (2)	27-0752
3	Plastic Multi Pad	4 (2)	27-0717
4	Rubber Gasket	4 (2)	27-0718
5	Security Key	1	22-0811
6	45mm Bolts	4 (2)	22-0220
7	Fitting instructions	1	
8	5 year warranty	1	

For the Single-Bar fitments, only the relevant Cross Bar and Bolts are included. The number shown in brackets denotes the quantity included in the Single-Bar fitments.

NOTE: Prior to Assembly

Prior to assembling, check that the kit contains all the parts you will need to fit the Roof Racks. Refer to the Parts List for guidance. Please read these fitting instructions prior to assembly.

STEP 1: Removing the Anchor Point Covers

- A. On the vehicle roof you will find 4 Anchor Point Covers paired in two locations indicated by the arrows in Fig 2. Carefully remove these covers by sliding in the direction shown on the cover, to reveal the anchor points. It is advisable to screw the Special Bolts into the Anchor Points at this time to clean the threads.

- ⚠ NOTE: Take care when removing Trim Covers to avoid damaging Trim Cover Clips. Covers can not be replaced while rack is fitted.
- ⚠ For a Single-Bar fitment, only remove the two Front or the two Rear covers, depending on the fitment.
- ⚠ Store the Anchor Point Covers and plugs safely while the Roof Racks are in use.

Location of Anchor Points on Vehicle Roof:

Fig. 2

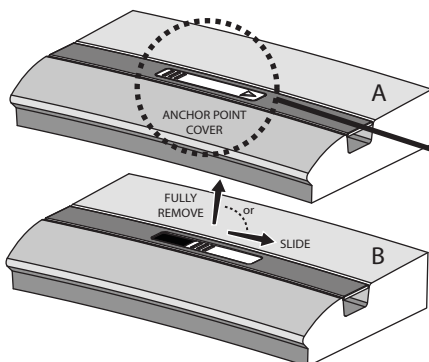
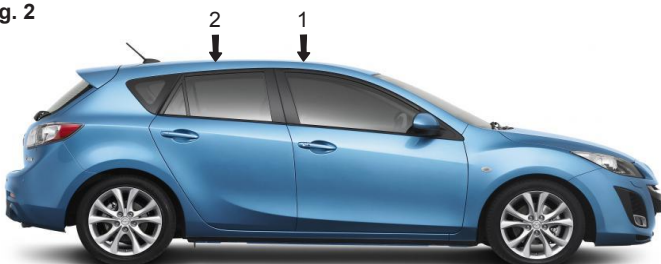
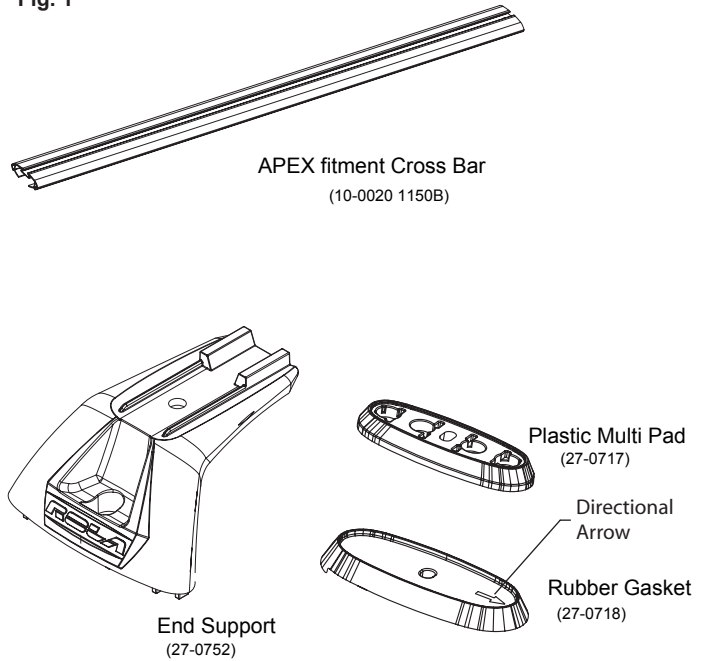
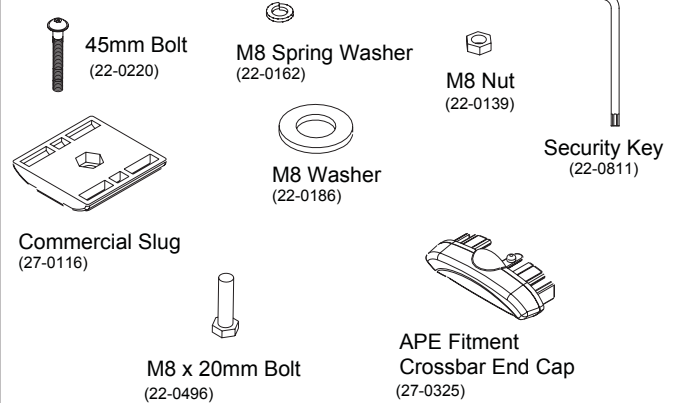

Fig. 1



Fit Kit - Hardware



Please Note: You will require the following tools

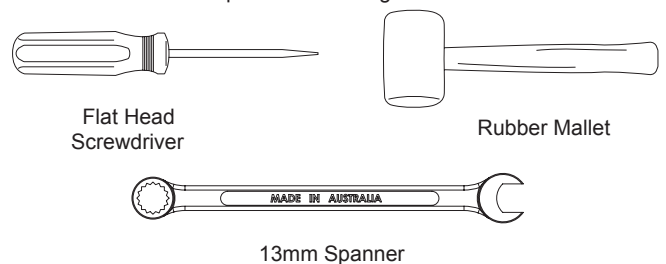
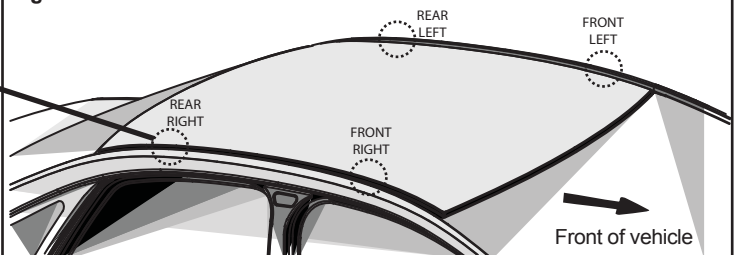

Fig. 3



FAILURE TO FOLLOW THESE INSTRUCTIONS WILL VOID WARRANTY

STEP 2: Installing the Rubber Gaskets and Multi Pads

A. Replace an Anchor Point Cover, From STEP 1, with one of the supplied Rubber Gaskets

- ⚠ Ensure the Rubber Gasket is oriented correctly (Fig. 4a).
- ⚠ Each Rubber Gasket is marked with a directional arrow (Fig. 4a.1).
- ⚠ Ensure that the center hole in the gasket lines up with the anchor point thread in the roof.
 For the front anchor point use the forward most threaded point.
 For the rear anchor point use the rearward most threaded point

B. Locate the Plastic Multi Pad onto the Rubber Gasket

- ⚠ Ensure the Multi Pad is oriented correctly (Fig. 4b).
- ⚠ Ensure that the center hole in the Multi Pad lines up with the anchor point thread in the roof.

C. Repeat STEPS A and B with the remaining Adaptors.

STEP 3: Fitting the Cross Bars to the Vehicle

A. Place an end support onto the adaptor from STEP 2, and loosely secure it down with a 45mm bolt by inserting the bolt into the anchor hole, and turning approximately 2-3 turns with the security key (Refer to Fig. 5a). Do not tighten yet. Repeat for the opposite side.

B. Place the crossbar onto the end supports ensuring that the end supports are located into the cutouts on the underside of the crossbar. (Refer to Fig. 5b)
 Check that the cross tube has equally distanced overhang on either side from the end support.

C. Insert the M8 nut into the cavity on the Commercial Slug. (Refer to Fig. 5c).

D. Insert the Commercial Slug into the cross tube, and align it so that the M8 nut in the Commercial Slug and the hole at the bottom of the end support line up. (Refer to Fig. 5c).

E. Secure the cross tube to the end support by screwing the M8x20mm bolt through the hole in the end support and up into the nut that is located in the cavity of the Commercial Slug. (Refer to Fig. 5c).

F. Using a 13mm Spanner, full tighten the 20mm bolt on the underside of the end support. (Refer to Fig. 5c).
 Using the Security Key, tighten the 45mm bolts to approximately 7Nm of torque or a firm hand-tightness. (Refer to Fig. 5c).

G. Insert an end cap into both ends of the cross tube (Refer to Fig. 5c).

STEP 4: Using the Roof Racks

A. Refer to 'Care for your Racks' to maintain your Roof Racks.

B. To load accessories into the Channel of the Cross Bars, remove the end cap from the end of the cross tube.
 Once the accessories have been loaded, re-insert the end cap back into the end of the cross tube.

Note: You will have to remove or trim the Buffer Strip to mount accessories

Intermittently check that all Screws and Bolts are sufficiently tightened whilst the Roof Racks are in use.

FAILURE TO FOLLOW THESE INSTRUCTIONS WILL VOID WARRANTY

