

Maximum Carrying Capacity: 2-Bars: 60 kg; 1-Bar: 30 kg

Parts List: (Refer to Fig.1a)

Item	Description	Qty.	Part No.
1	Cross Bars (with Buffer Strip)	2 (1)	Refer Fig.1a
2	Adaptors	4 (2)	Refer Fig.1a
3	3/8" Screw	4 (2)	22-0016
4	Spring Washer	8 (4)	22-0162
5	Flat Washer	8 (4)	22-0195
6	Rubber Washer	8 (4)	22-0519
7	O-Ring	8 (4)	22-0802
8	Red Security Key	1	22-0170
9	Grey Security Key	1	22-0356
10	25mm Bolt	4 (2)	22-0349
11	50mm Bolt	4 (2)	22-0514
12	60mm Bolt	4 (2)	22-0518
13	Locks (+ Keys)	4 (2)	LB04/LB02
14	End Support	4 (2)	MSES016
15	End Support Cover	4 (2)	25-0095

For the Single-Bar fitments only the relevant Cross Bar and Bolts are included. The number shown in brackets denotes the quantity included in the Single-Bar fitments.

NOTE: Prior to Assembly

Prior to assembling, check that the kit contains all the parts you will need to fit the Roof Racks. Refer to the Parts List for guidance. Please read these fitting instructions prior to assembly.

STEP 1: Fitting End Supports to the Cross Bars

Ensure the Lock Barrels have been inserted into the End Support Covers before assembly. Refer to Lock Barrel Kit Fitting Instructions.

A. Insert the End Support into the end of one of the Cross Bars (Fig. 2a). If required, use a rubber mallet to assist with assembling. Repeat with remaining End Supports.

Only use a rubber mallet to assist with assembling, as a hammer may damage the End Supports.

Ensure End Supports are oriented correctly. Refer to Fig. 2a.

B. Attach the End Support Cover. Insert the narrow end of the End Support cover into the top of the End Support (Fig. 2b). Twist the End Support Cover clockwise to lock it in place.

C. Peel back the Buffer Strip, on the Cross Bar, 30mm from the end to expose the Screw Hole in the Channel. Insert the 3/8" Screw into the hole and fully tighten such that the End Support is fixed to the Cross Bar (Fig. 2c). Replace Buffer Strip. Repeat with remaining End Supports.

STEP 2: Removing the Anchor Point Covers

A. Remove the four Anchor Point Covers from the roof of the vehicle (Fig. 3a.1). Remove the Bolts and Brackets (Fig. 3a.2). The Anchor Points should now be exposed.

For a Single-Bar fitment, only remove the two Front or two Rear covers, depending on the fitment.

Store the Anchor Point Covers, Bolts and Brackets safely whilst the Roof Racks are in use.

FAILURE TO FOLLOW THESE INSTRUCTIONS WILL VOID WARRANTY

Fig. 1a

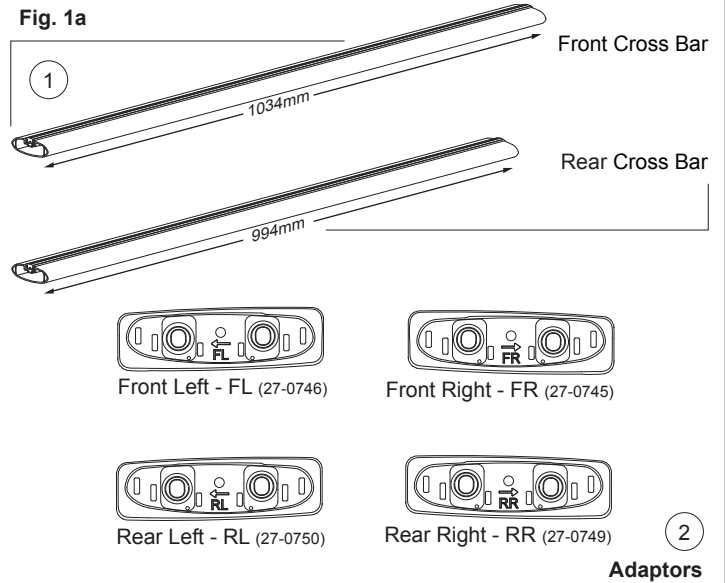

Please Note: You will require the following tools

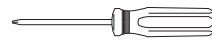

Phillips Head Screwdriver

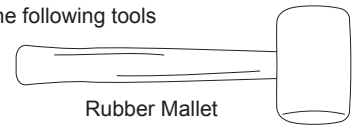

Rubber Mallet

Fig. 2a

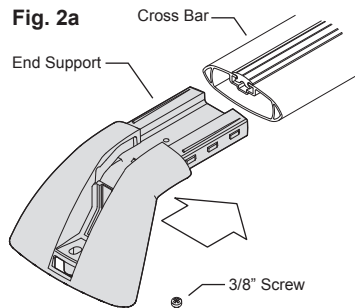

Fig. 2b

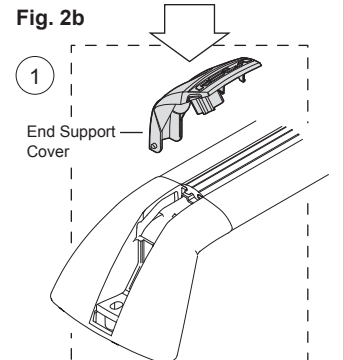

Fig. 2c

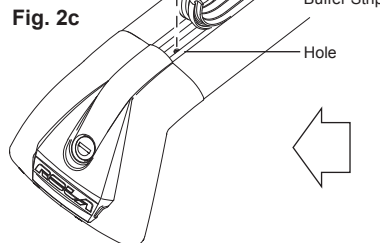
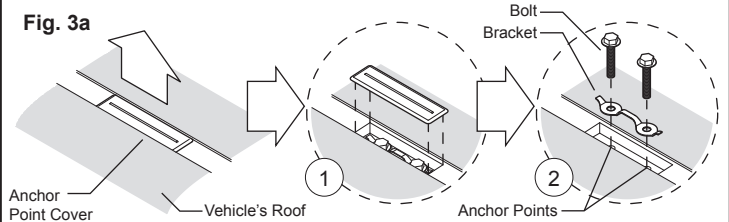

Fig. 3a



STEP 3: Installing the Adaptors

A. Replace an Anchor Point Cover, From STEP 2, with the corresponding Adaptor ensuring to place an O-Ring in both of the recesses on the underside of the Adaptor (Fig. 4a).

- ⚠ Ensure the Adaptor is oriented correctly (Fig. 4a).
- ⚠ Each Adaptor is marked with a unique identification code and direction arrow and belongs to a specific location (Fig. 4a.1).

B. Place a Spring Washer, Flat Washer and Rubber Washer on the threaded end of a 60mm (front) or 50mm (rear) Bolt. Insert the Bolt into one of the two large holes in the Adaptor (Fig. 4b.) Repeat with other hole.

C. Using the Red Security Key, tighten the Bolts to approx. 7Nm of torque or a firm hand-tightness such that the Adaptor is fixed to the vehicle.

D. Repeat STEPS A, B and C with the remaining Adaptors.

STEP 4: Fitting the Cross Bars to the Vehicle

A. Each Cross Bar varies in length:

- ⚠ The Cross Bar labelled '**Front**' (on the underside of the Cross Bar) belongs to the Front Adaptors (if purchased).
- ⚠ The Cross Bar with **no label** (on the underside of the Cross Bar) belongs to the Rear Adaptors (if purchased).

Refer to Fig. 1a for further guidance.

B. Place the End Supports of one of the Cross Bar Assemblies on the two corresponding Adaptors (Fig. 5a).

C. Lift the two End Support Covers such that the Anchor Hole is exposed. Loosely fasten both sides in place by inserting the 25mm Bolt into the Anchor Hole, and turning approx. 2-3 turns with the Grey Security Key (Fig. 5b).

D. Using the Grey Security Key, tighten the 25mm Bolts to approx. 7Nm of torque or a firm hand-tightness. Close the End Support Covers and lock using the Key provided.

E. Repeat STEPS B, C and D for the remaining Cross Bar Assemblies (if any).

F. Remove Keys and store in a safe place.

STEP 5: Using the Roof Racks

A. Refer to 'Care for your Racks' to maintain your Roof Racks.

B. To load accessories into the Channel of the Cross Bars, unlock the End Support Cover (Fig. 6a). Pull the Cover out and down to fully access the Channel. Once accessories have been loaded, replace the End Support Cover and lock.

Intermittently check that all Screws and Bolts are sufficiently tightened whilst the Roof Racks are in use.

FAILURE TO FOLLOW THESE INSTRUCTIONS WILL VOID WARRANTY

