



FITTING INSTRUCTIONS FOR
SUBARU IMPREZA G5 HATCH

2016 On

APX Removable Roof-racks

PART NUMBER: **APX140-2**

FITTING TIME: EST. 30 Minutes



ROOF-RACK LOADING CAPACITY: **60kgs**

ISSUE: A

ISSUE RELEASE DATE: 25/08/2017

TOTAL NUMBER OF PAGES INCLUDING COVERSHEET: 4

3. TOOLS AND MATERIALS REQUIRED

 <p>Cutting Knife - Use to open Kits, and trim Buffer Strip to size.</p>	 <p>Measuring Rule - Use to check dimensions and distances of cross-bars.</p>	 <p>Drill with 8mm bit Use to cut holes into weather strip</p>	 <p>Marking Pencil - Use to mark buffer strip.</p>	 <p>Phillips Head Screwdriver - Use to assemble Cross Bars.</p>
--	---	---	--	---

4. INSTALLATION STEPS

Prior to Assembly, check that your Roof Rack Box contains all the parts as listed above. Ensure the vehicle roof is clean and dry. Use Knife to cut through the packaging polybags.

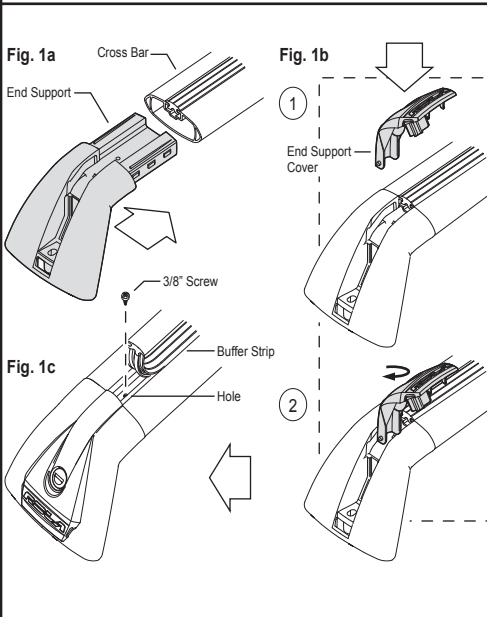

STEP 1

Ensure the Lock Barrels have been inserted into the End Support Covers before assembly. Refer to Lock Barrel Kit Fitting Instructions.

Insert the End Support into the end of one of the Cross Bars (Fig. 1a).

Repeat with remaining End Supports.

Attach the End Support Cover. Insert the narrow end of the End Support cover into the top of the End Support (Fig. 1b). Twist the End Support Cover clockwise to lock it in place.

Peel back the Buffer Strip, on the Cross Bar, 30mm from the end to expose the Screw Hole in the Channel. Insert the 3/8" Screw into the hole and fully tighten such that the End Support is fixed to the Cross Bar (Fig. 1c). Replace Buffer Strip. Repeat with remaining End Supports.

Fig 2



STEP 2

On the vehicle roof there are 4 concealed pairs of Anchor Points hidden under hatches in the vehicles weather strips. The locations of the covers are shown in Fig 2. Measurements are taken from the centre of the vehicles b-pillar.

Fig 3

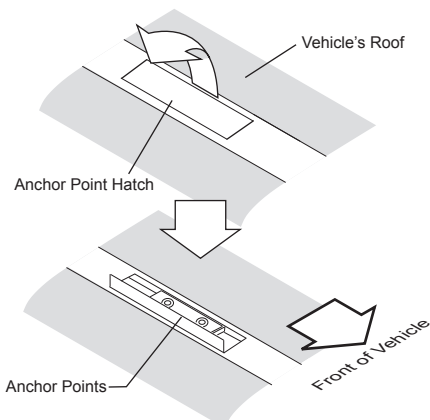

STEP 3

Carefully lift the hatches to reveal anchor points as seen in (Fig 3). There are 2 anchor points under each hatch. Either may be used but ensure that the same anchor point position is used on the LH side and RH side of the vehicle.

Fig 4

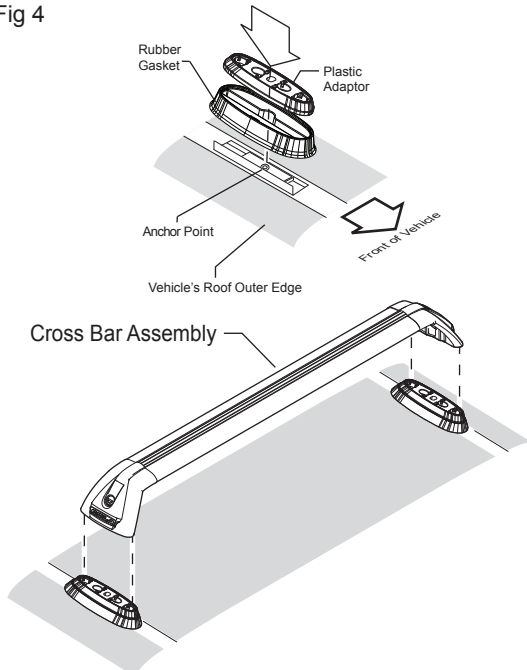

STEP 4

Place an adaptor block and gasket onto each of the anchor point locations ensuring they line up with the anchor points. Repeat for all 4 positions (Fig. 4).

Place an assembled cross bar onto the corresponding base plates.

Fig 5

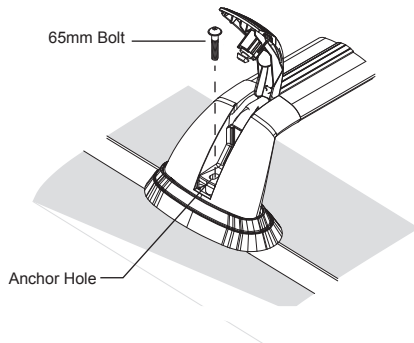

STEP 5

Lift the End Support Covers such that the Anchor Hole is exposed. Ensure that the hole in end support lines up with the hole in the base plates and vehicle anchor point.

Loosely fit the 65mm bolts. (Fig. 5) Repeat for all end supports then tighten all bolts with TT27 Assembly Key provided

Lock end support covers and store keys in a safe place.

Fig 6

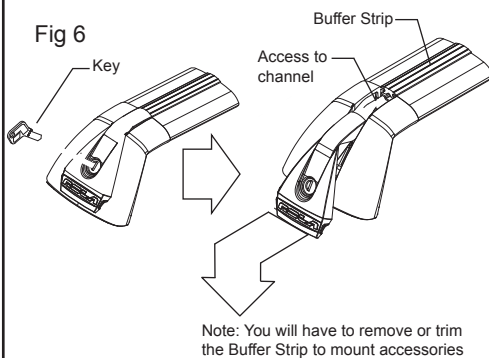

STEP 6

To load accessories into the Channel of the Cross Bars, unlock the End Support Cover (Fig. 6). Pull the Cover out and down to fully access the Channel. Once accessories have been loaded, replace the End Support Cover and lock.

USAGE INSTRUCTIONS

It is essential for the proper assembly, operation and use of the Roof-rack that the instructions and safety precautions supplied are strictly observed. The Maximum permissible load for your Roof Bar is the lower of the maximum load capacity specified in your vehicle operation manual, or specified as applying to the Roof-rack. Do not exceed the maximum specified Load capacity.

Maximum Permissible Load = Weight of the Roof-rack + Weight of Accessories + Weight of Load(Cargo).

When fitting the Roof-rack and transporting a load, ensure the vehicle's functions are not impaired (eg. sunroof, aerials, windscreen wipers, mirrors). Rear doors on Hatch - and wagon-type vehicles should be inspected for adequate clearance for full opening operation of the boot/tailgate.

Stop and check all screw connections, bolts and retaining straps after a short distance of travel. Repeat these checks at regular intervals.

WARNINGS

Remember that the fitting of a Roof-rack and the transport of a load increases the overall height of the carrying vehicle.

Where the roof-rack is to be used in off-road conditions, a safety weight reduction of 1.5 should be observed from the total carrying capacity (eg. 60kg becomes 40kg).

Cequent will not be liable to the purchaser of any other person for any consequential, direct or indirect loss, damage or costs incurred or suffered by the purchaser or any other person including but not limited to damage to persons or property, loss of turnover, loss of profits, loss of business or goodwill arising from or in relation to the assembly and use of the Roof-rack, or the non-observance of the fitting and care instructions.