

RIDGE MOUNT

by **ROLA**[®]

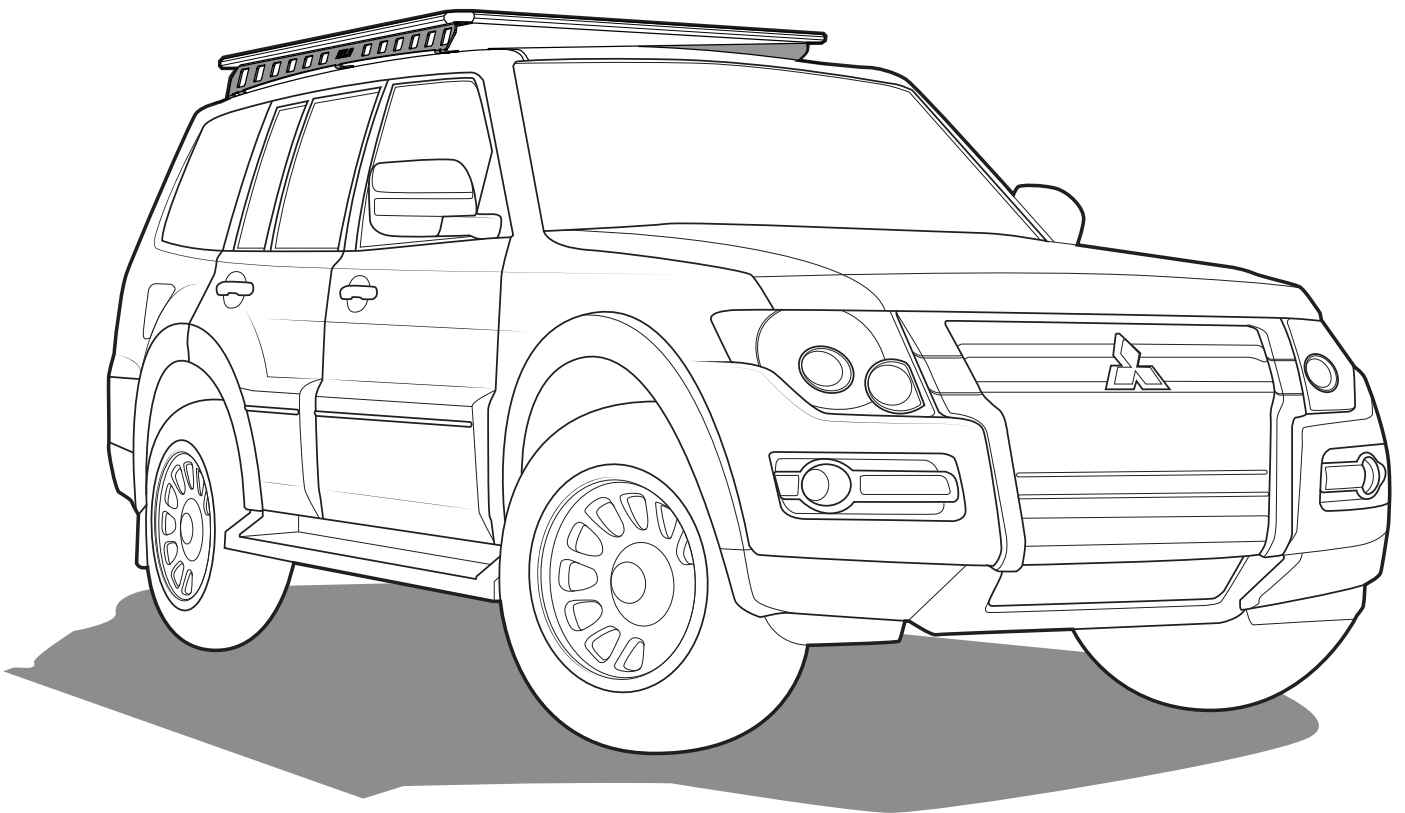

Read this full instruction prior to commencing assembly and fitment of Ridge Mount System.

CONTENT - CHECK ALL PARTS ARE CORRECT BEFORE PROCEEDING

A		Ridge Mount (pair)	1
B		M6 flat washer	10
C		M6 cap screw	10
D		M8 flat washer	36
E		M8 nyloc nut	24
F		M8 cap screw	12
G		Stud plate	6
H		Pajero spacer	10
I		Butyl patch	10
J		M6 flanged nut	10
K		Interlocking Block	3

TOOLS REQUIRED

- 6mm allen tool.
- 10/13mm spanner.
- Step ladder.
- Citrus cleaner.
- Trim removal tools.

1

Move to the side of the vehicle. Use a step ladder to get access to the vehicle roof.

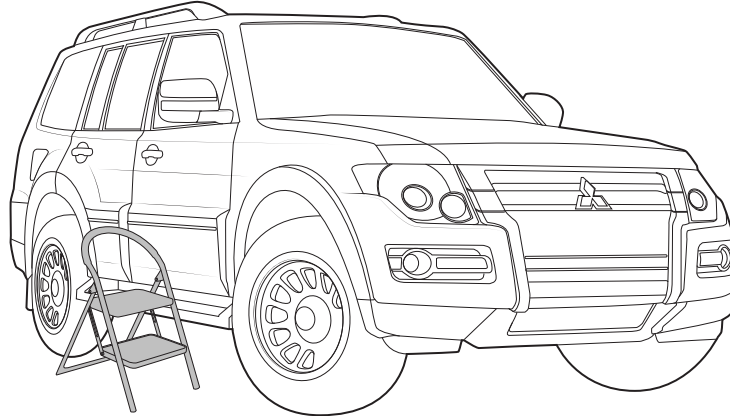

2

To remove the factory rails, the hood lining must be dropped. Begin with removing the sun visors and front seat belts from the B-pillar.

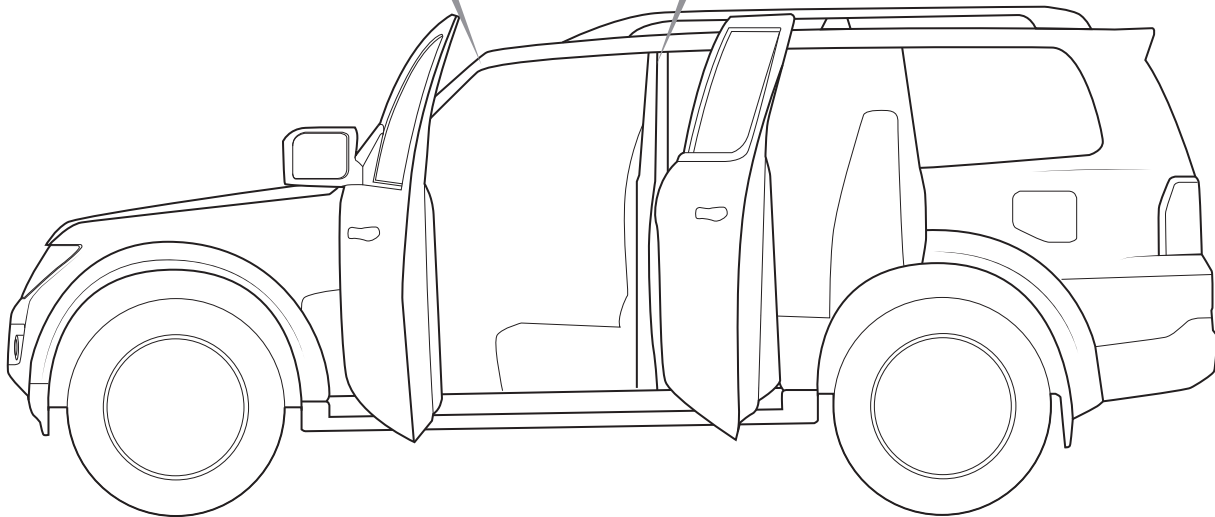
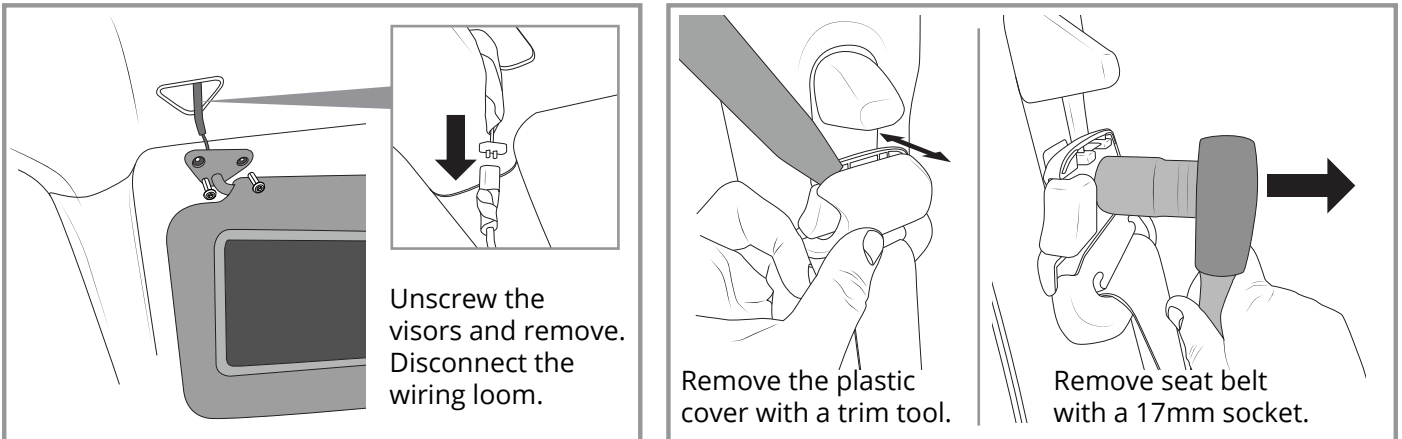

3

Pull the door seals down half way, do not fully remove. Carefully remove the grab handles from the middle and 3rd row.

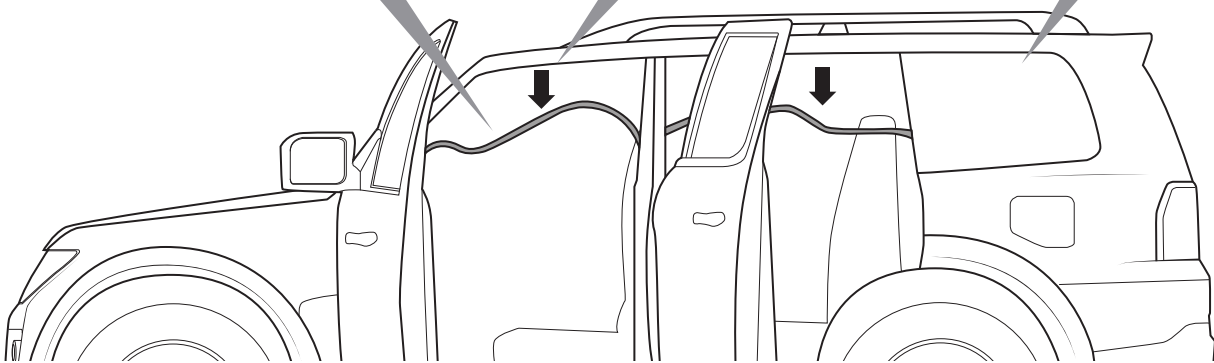
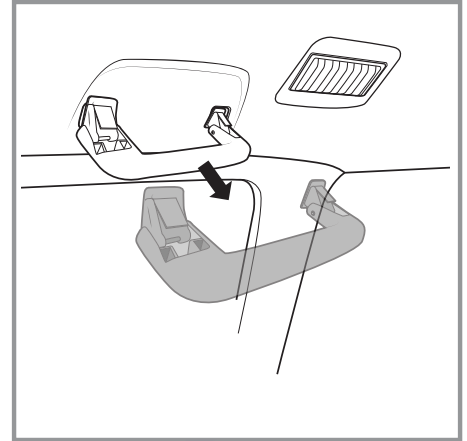
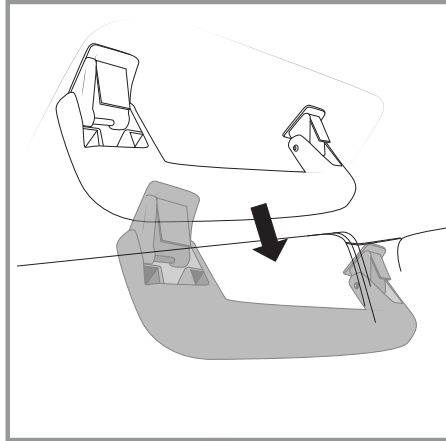
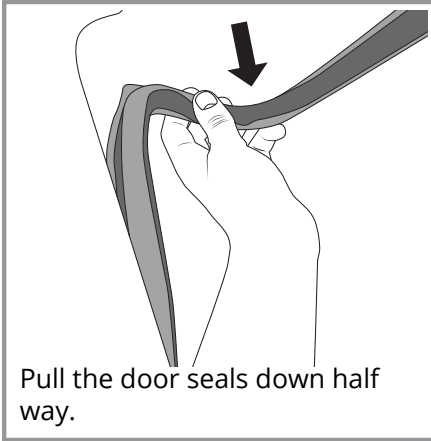

4

Carefully remove the B-pillar and 3rd row cowling as shown.

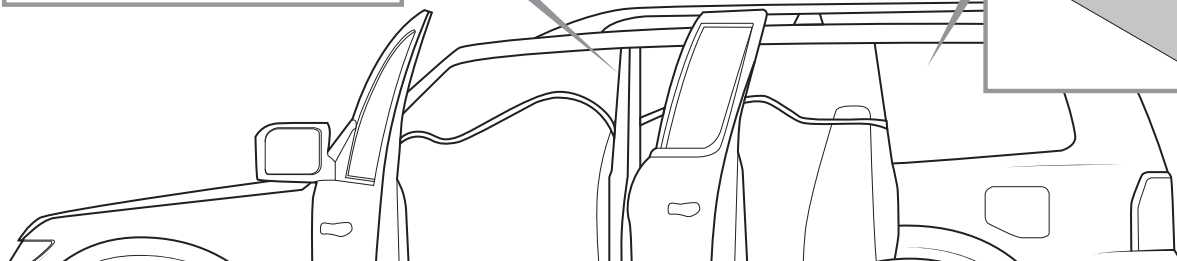
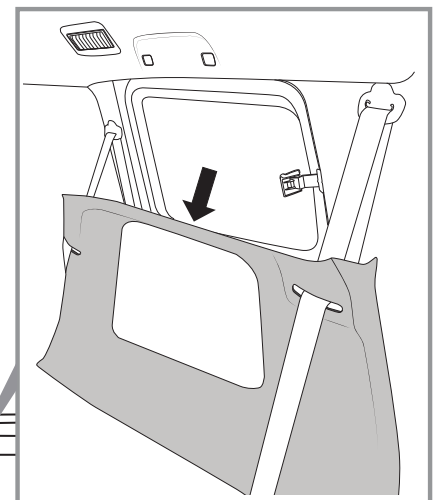
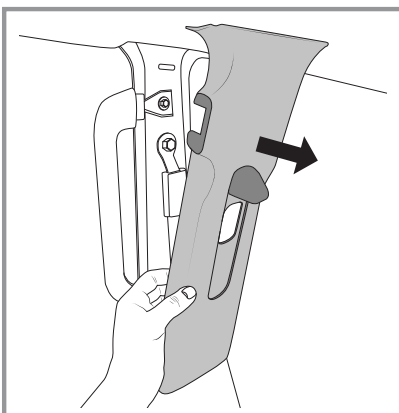

5

Finally remove the 4x plastic plugs in the roof, allowing the hood lining to come free.

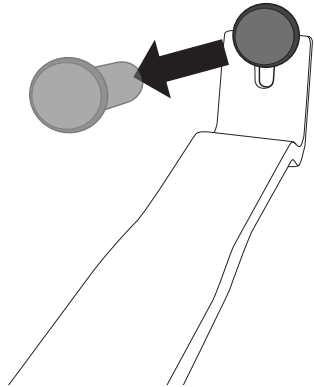

The roof lining can now be dropped.

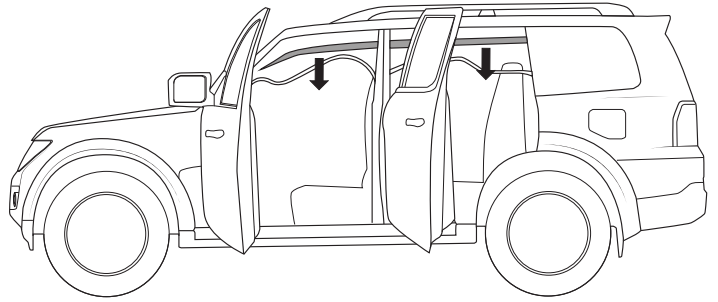

REAR AIRCON OPTIONED VEHICLES

6

If you have a rear air-conditioning system. It is recommended to fully remove the ducting prior to removing the roof rails. Begin by partially removing the door seal.

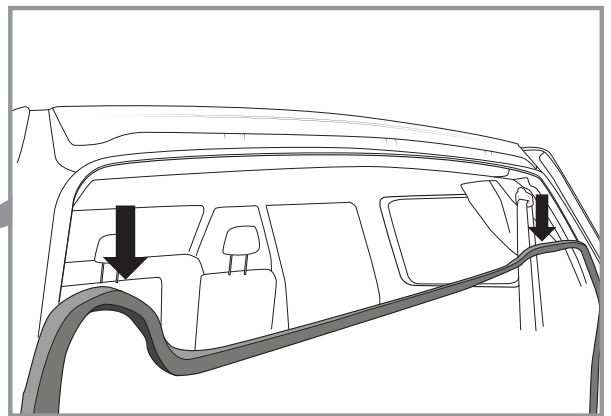
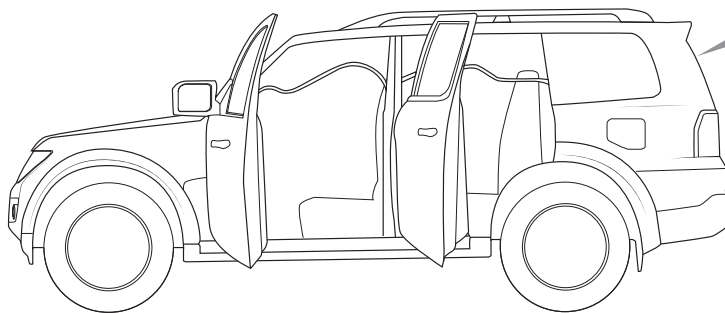

7

Remove the 4 plugs in the roof at the above rear door.

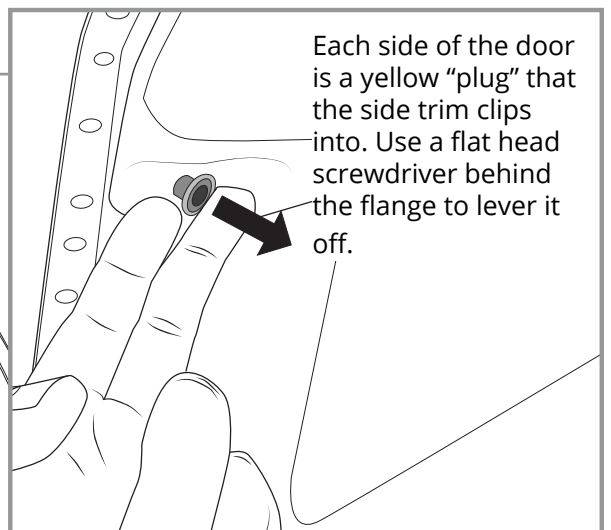
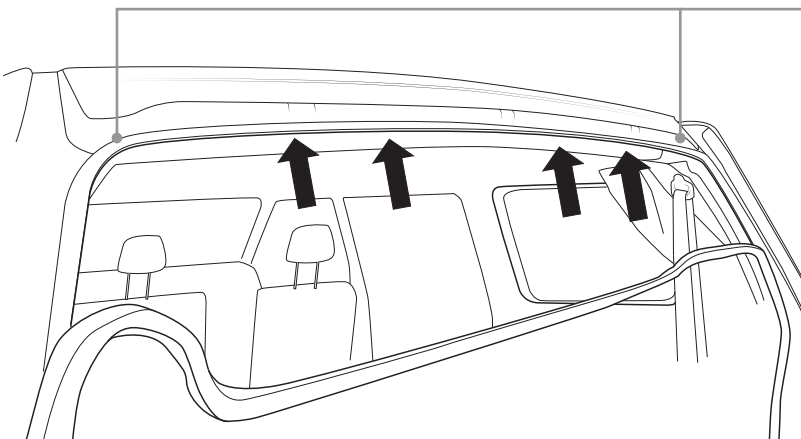

Each side of the door is a yellow "plug" that the side trim clips into. Use a flat head screwdriver behind the flange to lever it off.

8

Unscrew the rear AC ducting by remove the screws as shown (2x).
Unscrew the vertical ducting.

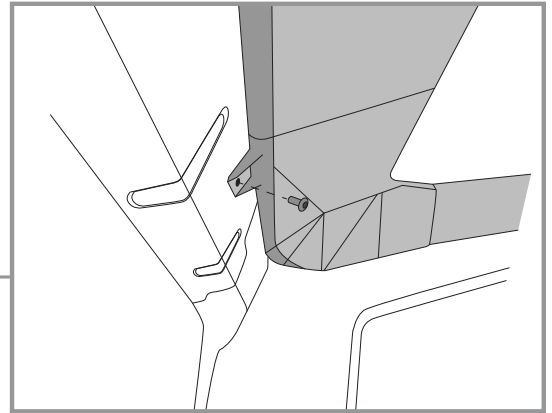
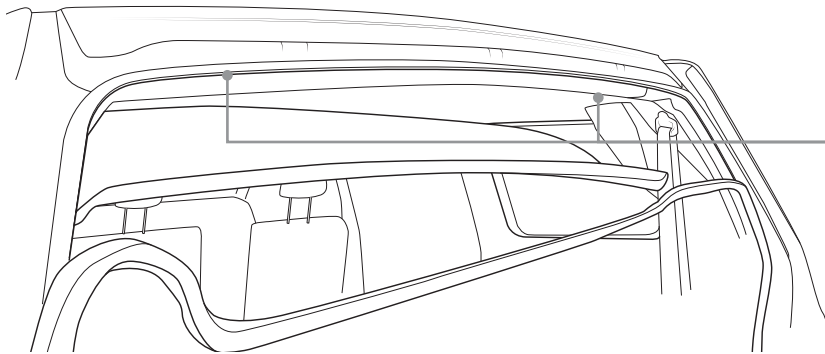

9

Once the roof lining is down. Unscrew LHS and RHS ducting which is screwed down in one place below the centre rail mounting point.

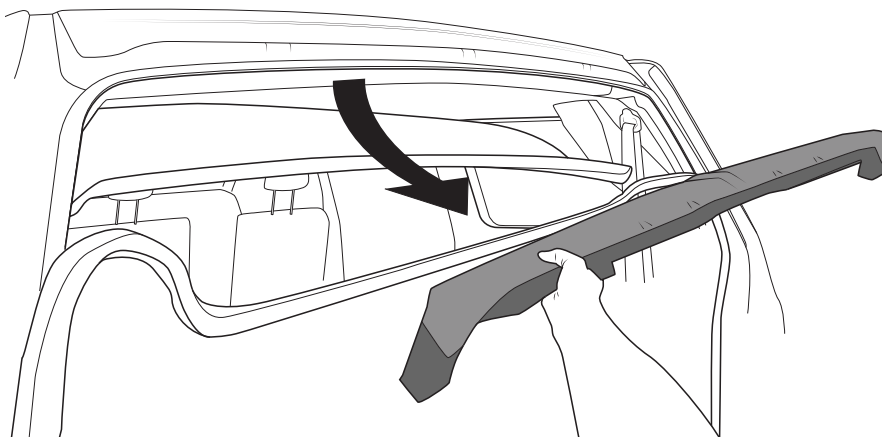

10

Locate the factory rail studs on the inside of the roof and remove the hardware, allowing the rails to be taken off.

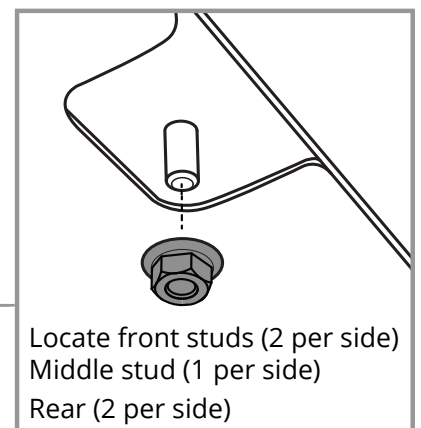
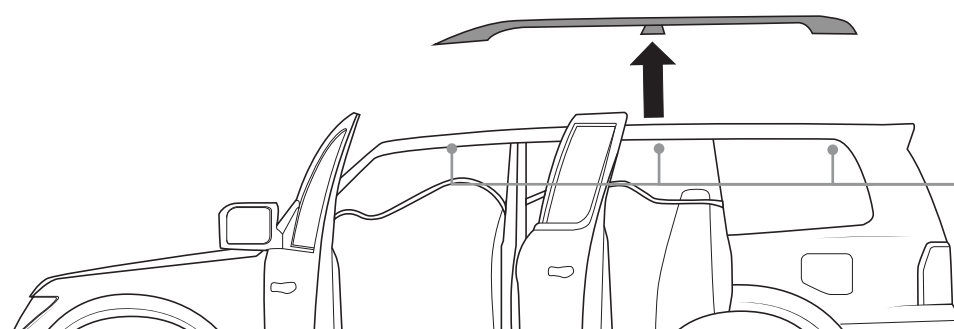

11

- (A) Clean the ditch where the factory rails have been removed.
- (B) Add a butyl patch to the exposed threads in the roof.

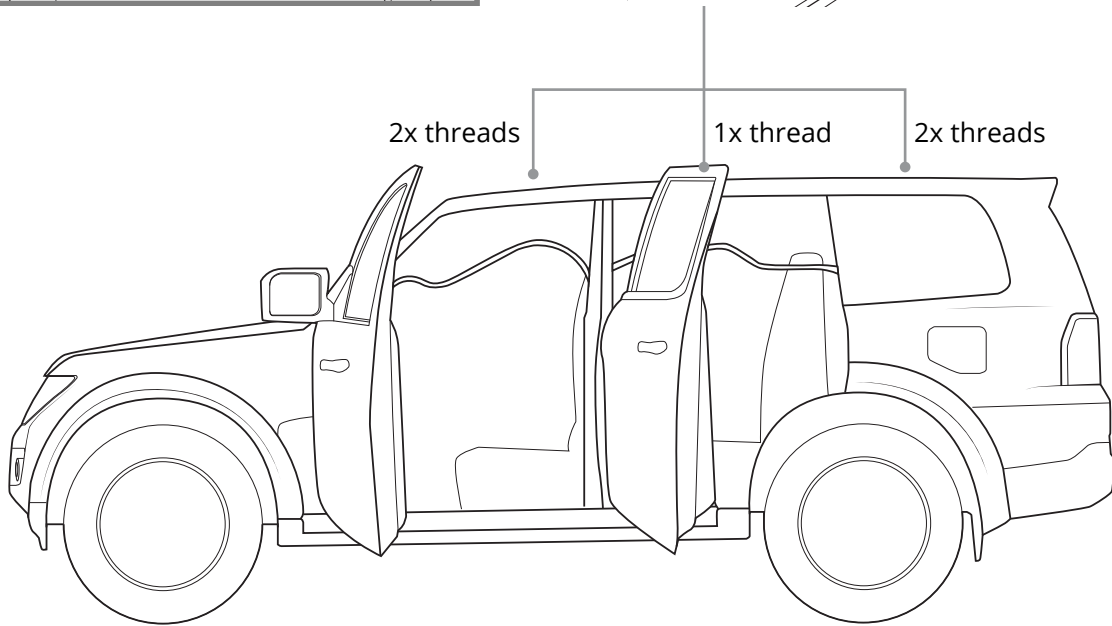
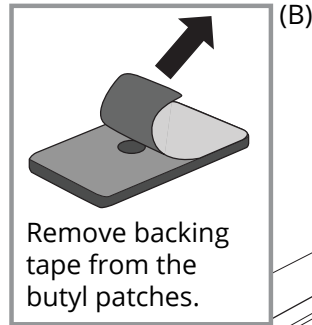
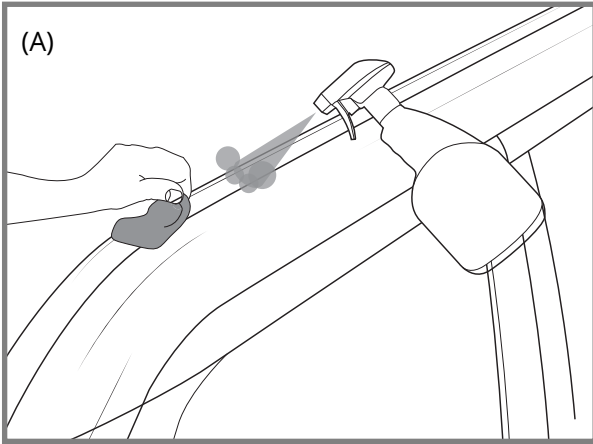

12

Place a spacer over each hole in the roof.

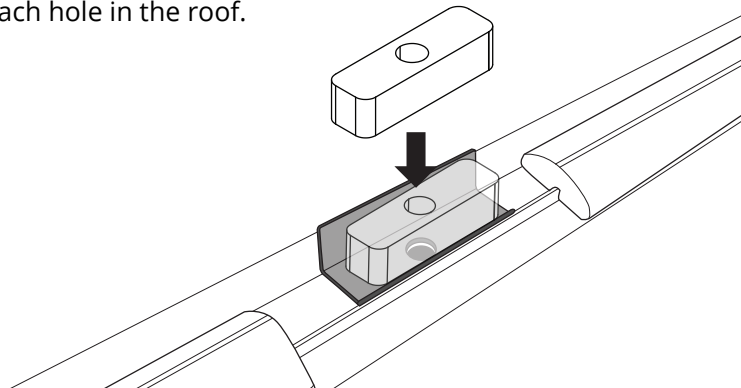

13

Insert M6 hardware as shown.

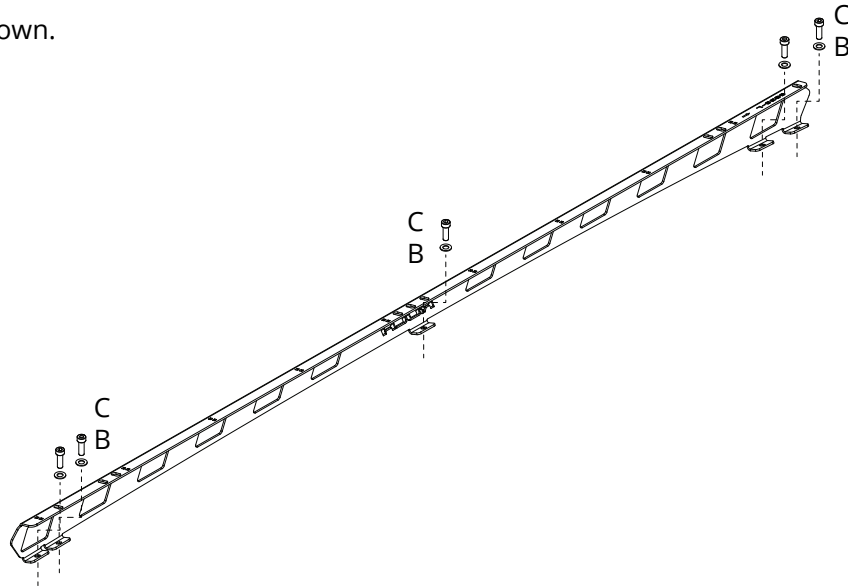

14

Install the Ridge Mounts into the roof of the vehicle.

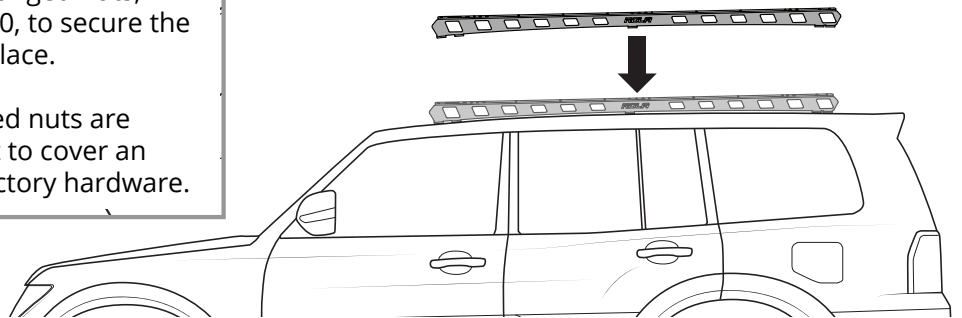
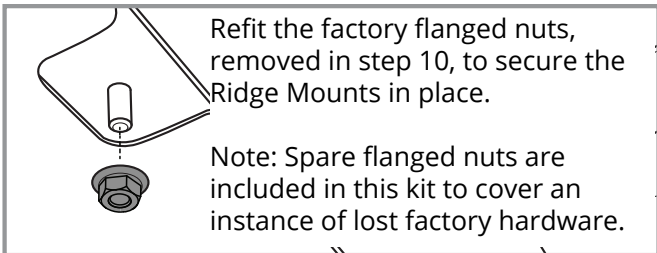

15

Install the stud plates to the Ridge Mounts.

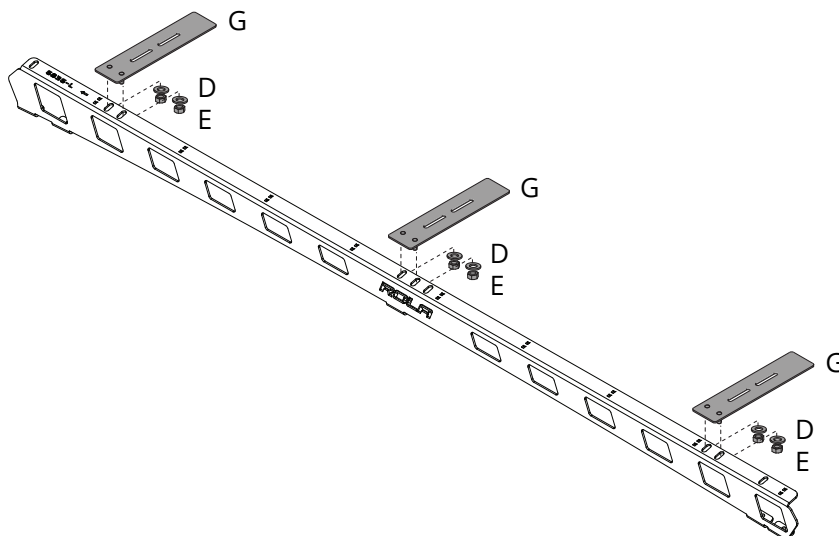

Reinstall the roof airduct and roof lining.

- Screw LHS and RHS ducting back into place.
- Reinstall rear ducting into LHS and RHS and screw in place.
- Follow removal steps backwards after this for re-installation.

TITAN TRAY FITMENT - as per Titan Tray instructions

Install the Rola Titan Tray as per corresponding instructions.

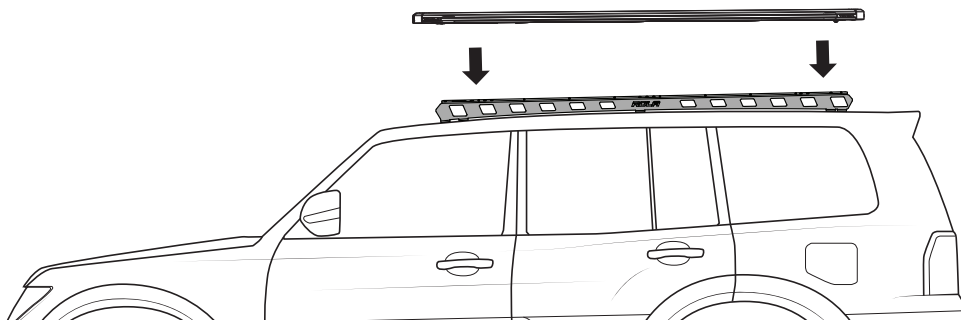
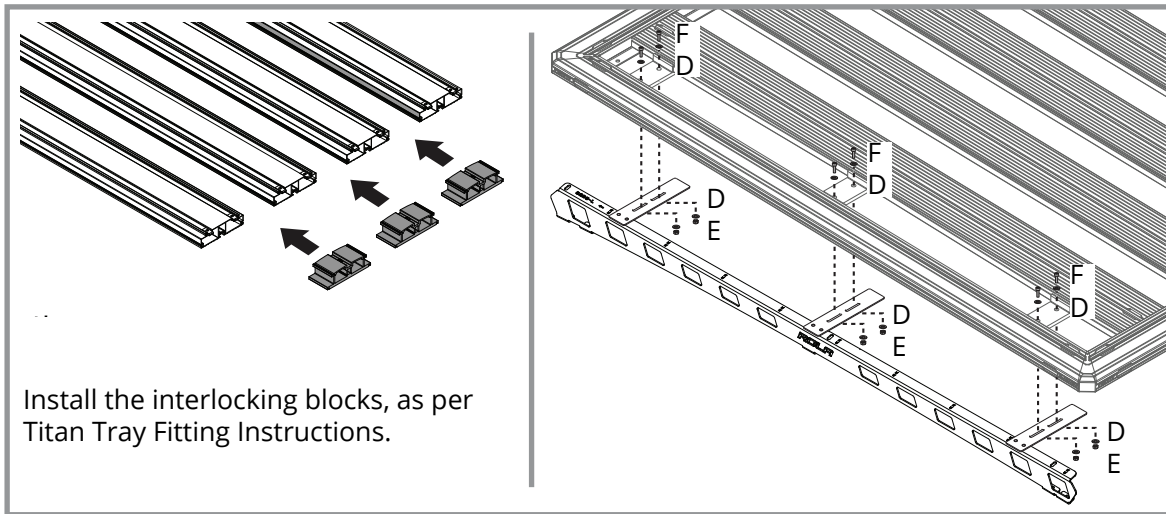

Note:

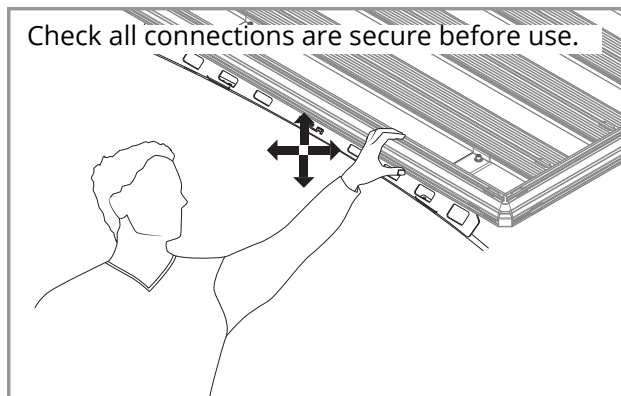

Wiring can be run and secured on the underside of the Ridge Mount rail as shown.

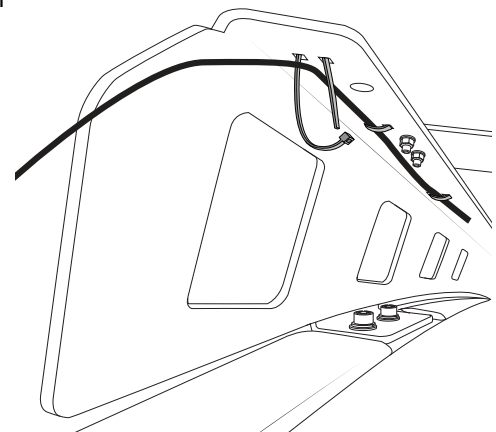

Check all connections are secure before use.

IMPORTANT - READ BEFORE USE

Please ensure the system is fitted in accordance with the fitting instructions. It is important that you observe all outlined below.

**LOAD RECOMMENDATIONS**

- Routinely and regularly check the proper functioning of the system. Check all fixtures at regular intervals.
- Do not use an automatic carwash with system installed.
- Maximum load capacity of the system is 400kg under static conditions.
- Maximum load capacity of the system is 100kg under dynamic including off-road conditions.
- Do not exceed vehicle manufacturers recommended load rating if it is lower than the maximum load capacity specified in this document (i.e., 100kg).
- Ensure any load carried is evenly distributed.
- Actual load on vehicle Roof (Refer to owner's manual) = Weight of Roof rack system / Ridge Mount + Weight of Tray + Weight of cargo.
- Actual load on rack system (Refer to product instructions) = Tray weight + cargo.

WARRANTY INFORMATION

Rola warrants that, subject to exclusions and limitations below, the Ridge Mount system will be free from defects in materials and workmanship for a period of 5 years commencing on the date of sale by the authorized Rola stockist to the original purchaser of the system.

If a defect appears in the Ridge Mount system before the end of the warranty period and Rola finds that the defect is in materials or workmanship, Rola will, in its sole discretion, either:

1. Repair the Ridge Mount or the defective component of the Ridge Mount system free of charge
2. Replace the Ridge Mounts or the defective component of the Ridge Mount system; or
3. Refund the purchase price of the Ridge Mount system to the original purchaser.

Rola reserves the right to change the design, specifications or composition of the Ridge Mount system without notice and without liability.

Rola reserves the right to replace defective products or components with products or components of similar quality, grade and composition, where an identical product or component is not available. Goods presented for repair may be replaced by refurbished goods of the same type rather than being repaired. Refurbished parts may be used to repair the goods.

The 5 year warranty does not apply where:

1. The Ridge Mount system is not installed in compliance with the fitting instructions provided
2. The Ridge Mount system is not used as intended or designed
3. Any part of the Ridge Mount system is used with other products or components not intended to be used in conjunction with the Ridge Mount system
4. The Ridge Mount system has been on-sold or assigned by the original purchaser
5. The Ridge Mount system has been modified or repaired by someone other than Rola or an authorized Rola stockist
6. Rola cannot establish any fault after inspection of returned product
7. The Ridge Mount system has been subject to abnormal conditions, including fire, water, humidity, pressure, stress or similar
8. The defect in the Ridge Mount system has arisen due to abuse, misuse, neglect or accident
9. The defect in the Ridge Mount system has arisen due to the unlawful or unusual operation of the vehicle to which it is fitted
10. The defect in the Ridge Mount system has arisen due to the purchaser's failure to properly assemble, install, fit, maintain or use the Ridge Mount system in accordance with the specifications and instructions provided by Rola.

For safety and use instructions, please refer to any General or Specific Fitting Instructions and Warning & Care Instructions enclosed within the Ridge Mount system or on our website at www.rola.com.au.

This warranty does not extend to fair wear and tear. Warranty claims can be made by contacting Rola directly using the details below. A warranty claim must be accompanied by proof of purchase (such as receipt), details of the alleged defect and appropriate documentation (such as historical and maintenance records where appropriate). The customer must make the product available to Rola or its authorized repair agent for inspection and testing. If such inspection and testing finds no defect in the product, the customer must pay Rola usual costs of service work and testing. It is the purchaser's responsibility to arrange and pay to return the product or component to the place of purchase. The purchaser may seek reimbursement from Rola for the cost of such activities, providing Rola notifies the purchaser in writing that a warranty claim is justified. Any such claims made must be in writing via post or email.

The benefits of this warranty are in addition to any rights and remedies imposed by Australian State and Federal legislation that cannot be executed. Nothing in this warranty is to be interpreted as excluding, restricting or modifying any State or Federal legislation applicable to the supply of goods and services which cannot be so excluded, restricted or modified. Our goods come with guarantees that cannot be excluded under the Australian Consumer Law. You are entitled to a replacement or refund for a major failure and for compensation for any other reasonably foreseeable loss or damage. You are also entitled to have the goods repaired or replaced if the goods fail to be of acceptable quality and the failure does not amount to a major failure. Rola makes no express warranties or representations other than set out in this warranty.