

- ① - 2 x Cross-bars & Buffer Strips (Front & Rear)
- ② - 1 x Set of (4) -RBXL-Covers and Locks
- ③ - 4 x End Supports
- ④ - 1 x Top & Bottom Strap Brackets
- ⑤ - 1 x Small Parts & Hardware Kit

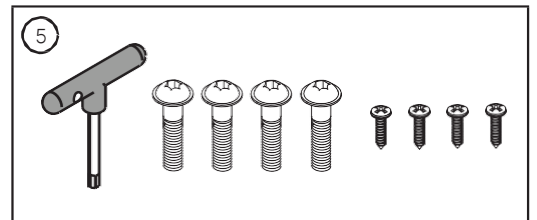

Please Note: You will require the following tools

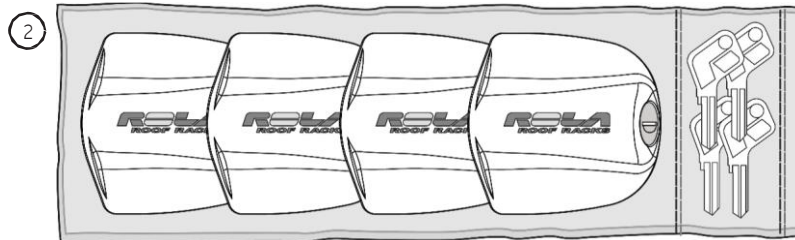
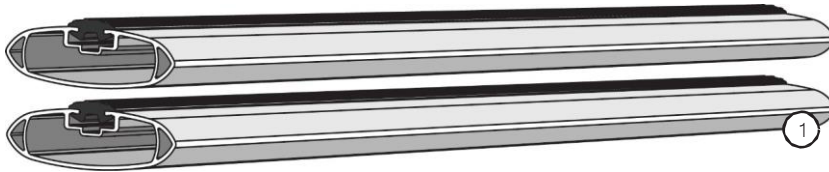
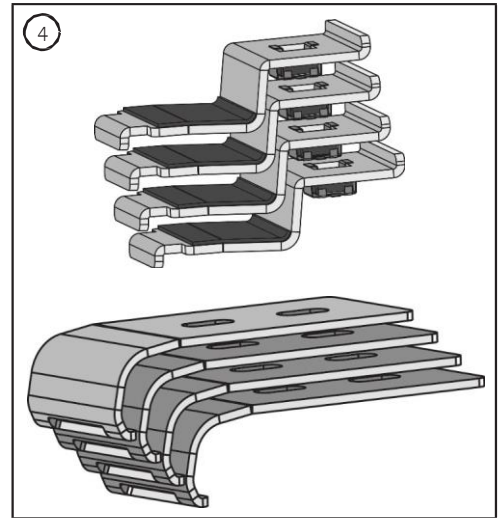
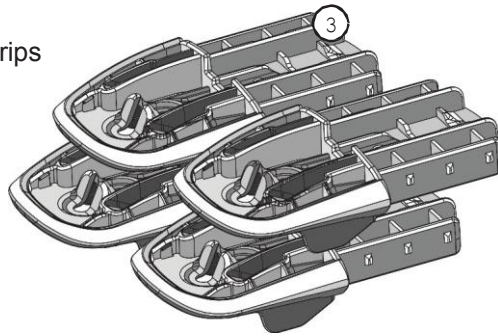

Phillips Head Screwdriver



Flat Head Screwdriver

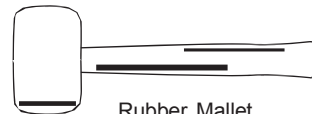

Rubber Mallet

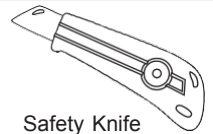

Safety Knife

Please check your roof-rack box to ensure you have received all components. Read these instructions thoroughly before commencing installation. (Please contact your dealer if your roof rack kit is incomplete)

ASSEMBLY OF CROSS BARS

1. Ensure that the Rail Bars are clean; free from dust and grease.
2. Pre-assemble the End Supports into Cross Bars. They are designed to be a tight fit: Use a rubber mallet if necessary (Fig.1).
3. Slide Top Strap into End Support Chassis (as shown in Fig 2). Fit Star-Head Bolt through the slot closest to the curled end of the Top Strap.
4. Push rubber Buffer Strip back about 20mm until you can see the screw hole in the cross bar. Using a Phillips head screw-driver, fasten the screw through the cross bar and into the End Support Chassis (Fig 3). Replace Buffer Strip.

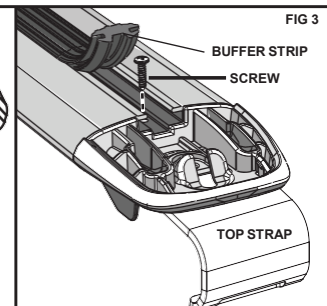
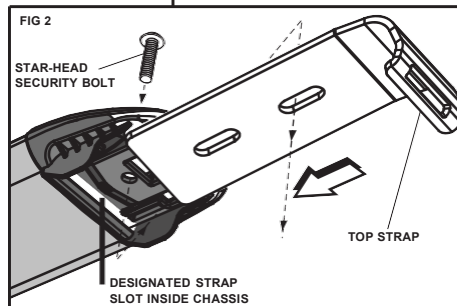
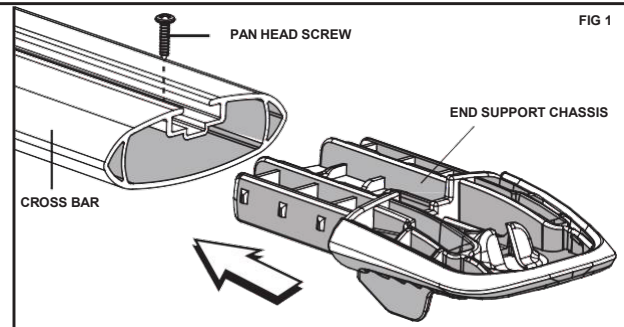

5. Prior to placing the cross-bar assembly on the rails, pull the Top Strap out slightly(5 to 6 mm) to allow Cross Bars to fit onto the vehicle Rail Bars.

Place Cross Bars on the vehicle at the recommended positions shown along the Rail Bars (Fig. 4).

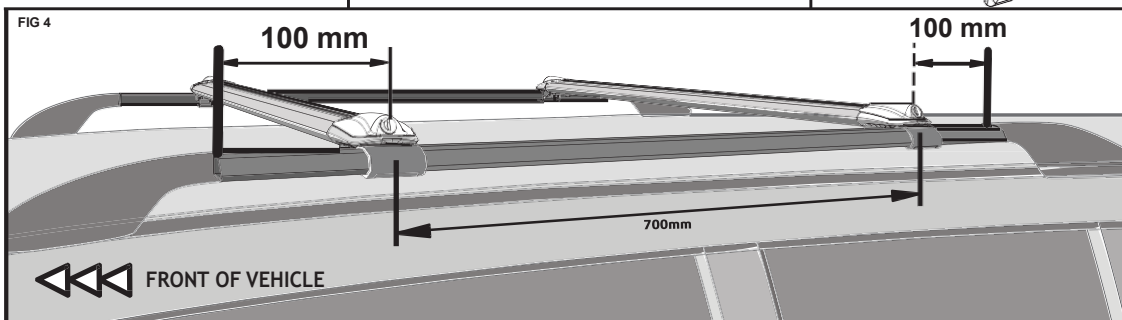

FITTING OF CROSS BARS TO VEHICLE

FIG 5

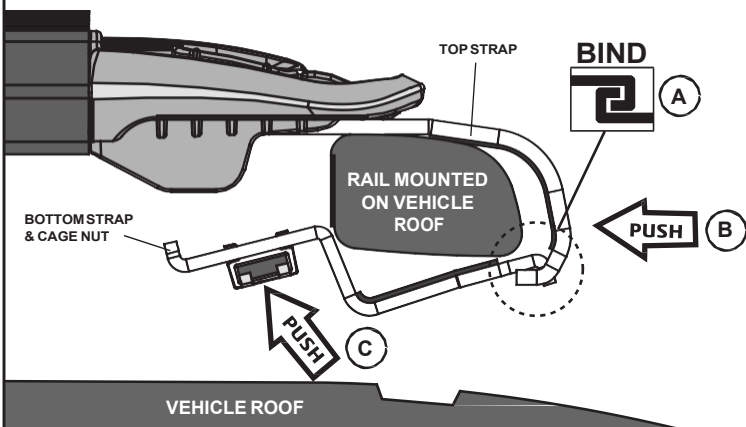
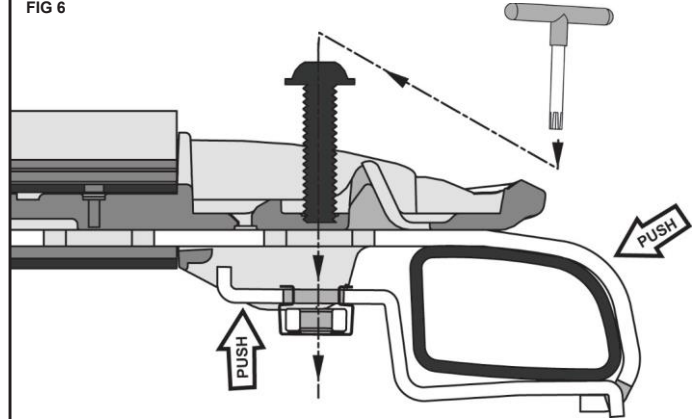

FIG 6



INSERTING COVERS

6. With the Top Strap sitting slightly outboard of the rails, proceed to feed the Bottom Strap around the rail and in position as shown in (Fig.5). Ensure to Bind the two straps together (A). Secondly, push the joined straps together up against the vehicle's rail. (B) As you push inwards, also push the Bottom Strap upwards, to bring the straps horizontally parallel to each other. (C).

7. As you push the Bottom Strap upward, introduce the Star Head Bolt through the End Support & Straps. Using the T-Handle provided, fasten the Straps together - ensuring they are fixed in the correct positions along the rail as specified in (Fig. 4) on the first page. Gradually tighten bolts alternatively ensuring Straps are properly engaged, until even tensioning is achieved.

Ensure that both bars are parallel to each other and the straps are tightly mounted against the rail. Ensure the bolts are tightened and the cross bars are well secured. Perform a quick check by tugging the bars back and forth.

8. Remove covers from Kit. Locate 2 ribs on the underside of the cover (Fig. 8). There are also two designated channels on the End Support Chassis into which these ribs locate. (Fig 7). Insert the Cover into the End Support Chassis by sliding it through the channels until they positively mate.

FIG 7

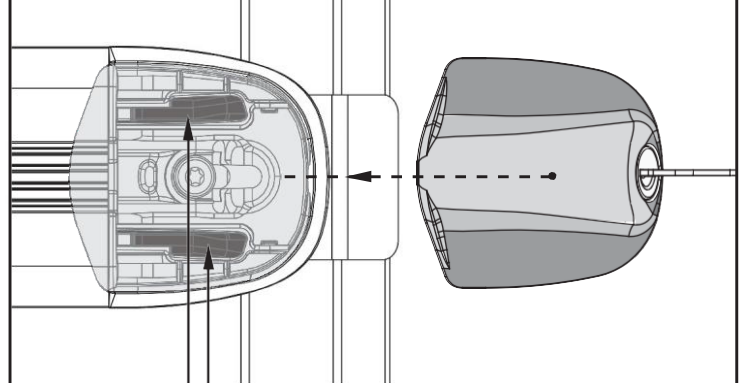
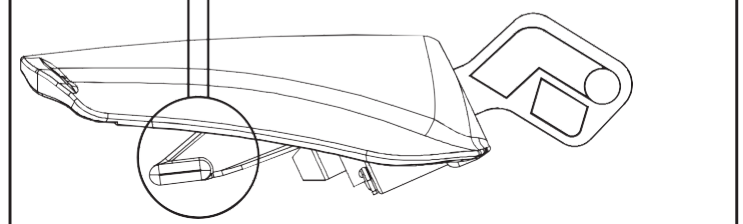

FIG 8



LOCKING AND REMOVING COVERS

9. The Cover Keys should now be inserted into all 4 covers. With the keys in place, lock the cylinder by rotating 1/4 turn clockwise. (Fig 9) Repeat this process for all 4 covers. Please store the keys in a safe place, ie. with car Keys or in vehicle's glove compartment.

10. To remove the Covers, firmly grip the edge of the cover with your fingers (as shown by arrow ① in Fig. 11), and pull the cover towards you - (arrow ② in Fig. 11)

TIP: Ensure the covers are locked into place on the End Support when you store your roof-racks away.

FIG 9

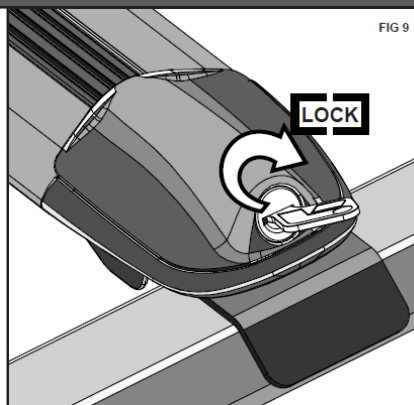
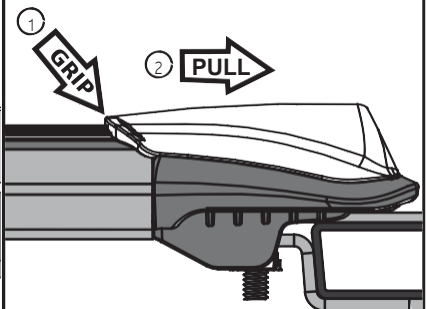

FIG 10



USAGE INSTRUCTIONS

It is essential for the proper assembly, operation and use of the Roof-rack that the instructions and safety precautions supplied are strictly observed. The Maximum permissible load for your Roof Bar is the lower of the maximum load capacity specified in your vehicle operation manual, or specified as applying to the Roof-rack. Do not exceed the maximum specified Load capacity. Maximum Permissible Load = Weight of the Roof-rack + Weight of Accessories + Weight of Load (Cargo). When fitting the Roof-rack and transporting a load, ensure the vehicle's functions are not impaired (eg. sunroof, aerials, windscreen wipers, mirrors). Rear doors on Hatch - and wagon-type vehicles should be inspected for adequate clearance for full opening operation of the boot/tailgate. Stop and check all screw connections, bolts and retaining straps after a short distance of travel. Repeat these checks at regular intervals.

WARNINGS

Remember that the fitting of a Roof-rack and the transport of a load increases the overall height of the carrying vehicle. Where the roof-rack is to be used in off-road conditions, a safety weight reduction of 1.5 should be observed from the total carrying capacity (eg. 60kg becomes 40kg). Cequent will not be liable to the purchaser of any other person for any consequential, direct or indirect loss, damage or costs incurred or suffered by the purchaser or any other person including but not limited to damage to persons or property, loss of turnover, loss of profits, loss of business or goodwill arising from or in relation to the assembly and use of the Roof-rack, or the non-observance of the fitting and care instructions.