

ROLA®

R-RMTH-01 RAPID SHOVEL HOLDER

PN	DESCRIPTION	QTY
1	RUBBER MULTI TOOL HOLDERS	2
2	M6 x 23mm BTN HEAD SCREW	2
3	M6 FLAT WASHER	2
4	M6 T-NUT	2

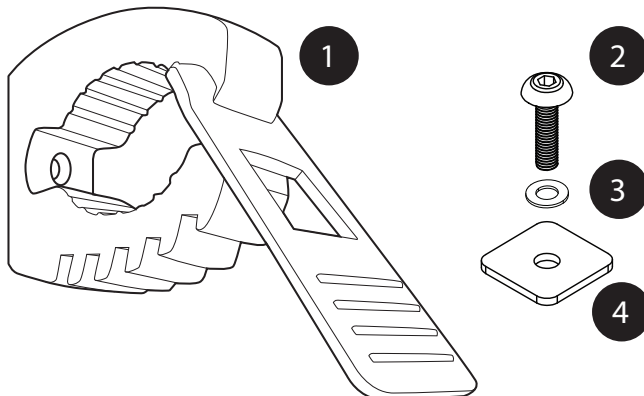

Tools Required:
Tape measure

Tools Supplied:
5mm Allen Tool

1 Insert T-nuts into the desired channel of the Platform.

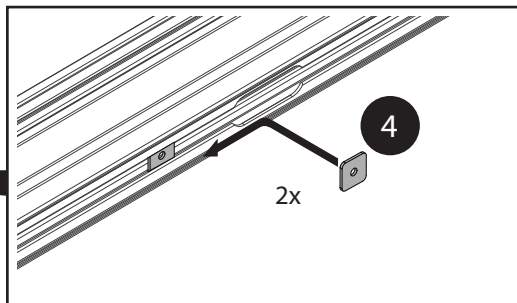
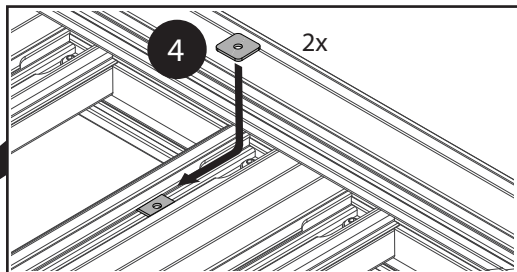
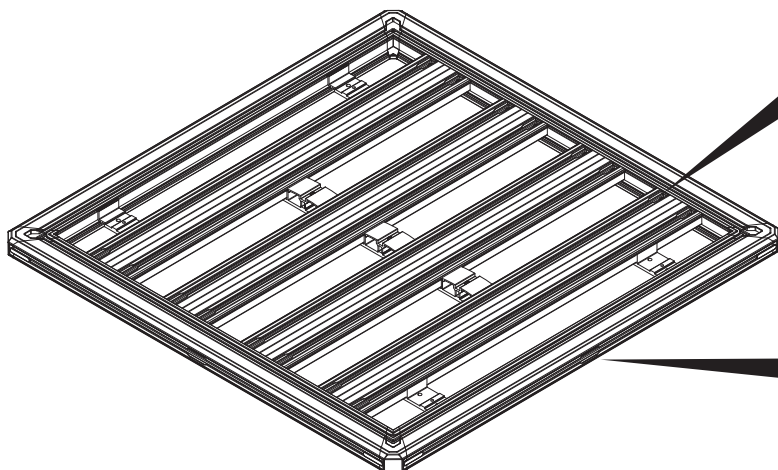

2 Measure size of tool to be carried.

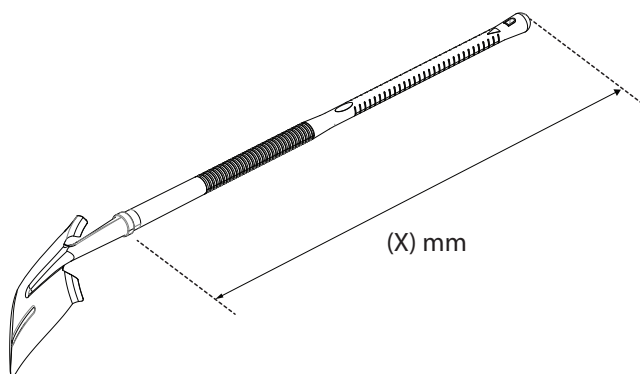

3 Using the M6 hardware provided, loosely fix the Rubber holders to the platform.

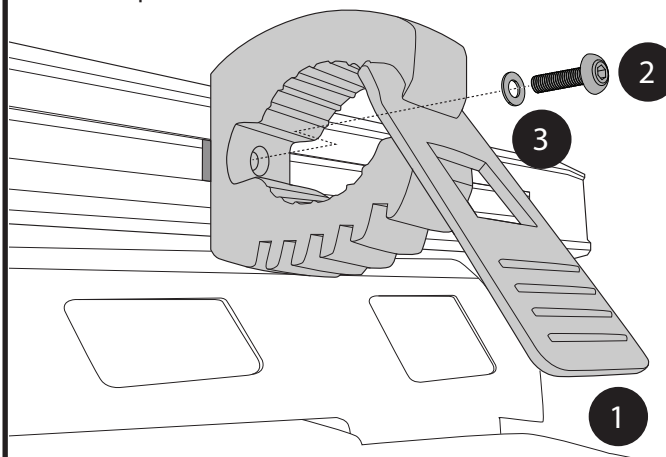

JUST ADD ADVENTURE

ROLA

