



NUDGE BAR

FITTING INSTRUCTIONS



TOYOTA FORTUNER 2015 ON PK101TTF15

Fitting Time : approx. 1.5-2 hours



BULL BAR SAFETY NOTICE:

INSTALLATION SHOULD ONLY BE DONE BY APPROPRIATELY QUALIFIED OR EXPERIENCED PERSONS IN ACCORDANCE WITH THESE INSTRUCTIONS.

IT IS THE RESPONSIBILITY OF THE INSTALLER TO ENSURE THAT THE PRODUCT IS CORRECTLY FITTED.

WARNING:

- Do not attach Vehicle Frontal Protection System (**VFPS**) to the vehicle using anchorages not intended for this purpose. (e.g. engine mounting bolts)
- Do not use this product for any vehicle make or model, other than those specified by the VFPS manufacturer.
- Do not remove the plaque or label from the VFPS.
- Do not modify the structure of the VFPS in any way.
- The VFPS has been produced to provide continued functionality of parking sensors and other "driver assist" features as closely as possible to Original Equipment. However, as all possible road conditions and combination of other accessories fitted to the vehicle which may affect functionality characteristics cannot be anticipated, ***the driver remains responsible at all times for properly controlling the vehicle, monitoring all "driver assist" features and intervening where required to ensure the vehicle is safely operated.***

IMPORTANT INFORMATION:

- Before installing the VFPS:
 - Check that all components, as listed in the assembly table, are available.
 - Thoroughly read all instructions.
- This product or its fasteners must not be modified in any way.
- These instructions are accurate as at the revision date and do not take into account any changes made by the vehicle manufacturer to vehicle design after the revision date or other accessories that are or have been fitted to the vehicle. Piak cannot be held responsible for such changes and appropriate enquiries should be made before installation.
- Before installing, inspecting and/or maintaining the VFPS, the work space should be safe and clear of fuel, debris, electrical or other components.
- During installation:
 - It is the responsibility of the installer to confirm correct operation/clearance of all components.
 - All holes drilled shall have all burrs and swarf removed then coated with a suitable rust preventative paint.
 - Ensure that all hardware is fastened to torque list as detailed in these instructions.



MAINTENANCE AND CARE:

To ensure continued safety and correct operation of the product, the VFPS must be routinely inspected and regularly serviced (including bolt torque checked for correct tension) by an appropriately qualified or experienced person.

The high tensile fasteners supplied with this product were used to achieve the specified rating. If replacement of the fasteners is required, fasteners of the same rating and quality must be used.

If this VFPS is fitted with a hinged number plate bracket, extra care must be taken when returning back to public roads following the use of the winch or conducting a deep water crossing.

The driver must ensure that the number plate bracket is returned back to the down position allowing full visibility of the number plate when returning to public roads.

EQUIPMENT:

These safety products should, at a minimum, be used when fitting or working on the product.



Protective Glasses



Hearing Protection

Installation in accordance with these instructions and adherence to warnings will ensure compliance with relevant regulatory and safety standards as at the revision date.

Failure to adhere to these instructions may affect the roadworthiness of the vehicle or cause personal injury, death or damage to property.

BY USING THIS PRODUCT YOU ACKNOWLEDGE AND AGREE THAT TO THE EXTENT PERMITTED BY LAW PIAK WILL NOT ACCEPT LEGAL OR OTHER LIABILITY FOR ANY LOSS, INJURY OR DAMAGE CAUSED BY INCORRECT OR INAPPROPRIATE INSTALLATION OR USE OF THE PRODUCT.

TOOLS REQUIRED

1. Metric socket and spanners
2. Phillips and flat head screw driver
3. Torque wrench
4. Marking pen
5. 2" Masking tape
6. Jigsaw
7. Test lamp or multi-meter
8. Drill and metric drill bits

PARTS LIST

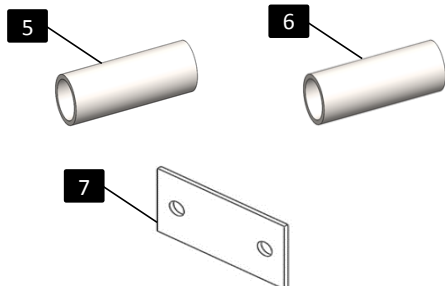
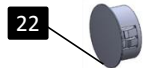

Important : Check contents of fitting kit before commencing fitment and report any discrepancies.

Steel Nudge bar				
Item	Component Name	Q'ty	Remarks	
1	Nudge Bar Fortuner 2015	1		
2	Front Protection Plate	1		
Chassis Mounts to Vehicle				
Item	Component Name	Q'ty	Remarks	
3	Chassis Mount RH	1		
4	Chassis Mount LH	1		
5	Spacer Tube Ø25x55mm	2		
6	Spacer Tube Ø16x55mm	2		
7	3 mm Spacer 70 x 122 x 3T	2		
8	Hex bolt M10 x 1.5 x 90 Zn	4		
9	Hex bolt M10 x 1.25 x35 Zn	6		
10	Flat washer M10 OD27 Zn	14		
11	Spring washer M10 Zn	10		
12	Hex nut M10 x 1.5 Zn	4		
13	Flange nut M10 x 1.25 Zn	2		
Bull Bar to Chassis Mounts				
Item	Component Name	Q'ty	Remarks	
14	Hex bolt M10 x 1.25 x 35 EDP	4		
15	Flat washer M10 OD27 EDP	8		
16	Spring washer M10 EDP	4		
17	Flange nut M10 x 1.25 EDP	4		
License Plate				
Item	Component Name	Q'ty	Remarks	
18	Hex bolt M6 x 1.0 x 20 EDP	2		
19	Flat washer M6 OD14 EDP	2		
20	Spring washer M6 EDP	2		
21	Flange nut M6 EDP	2		
Accessories				
Item	Component Name	Q'ty	Remarks	
22	Sensor Plug OD19	2		

PARTS LIST CONTINUED

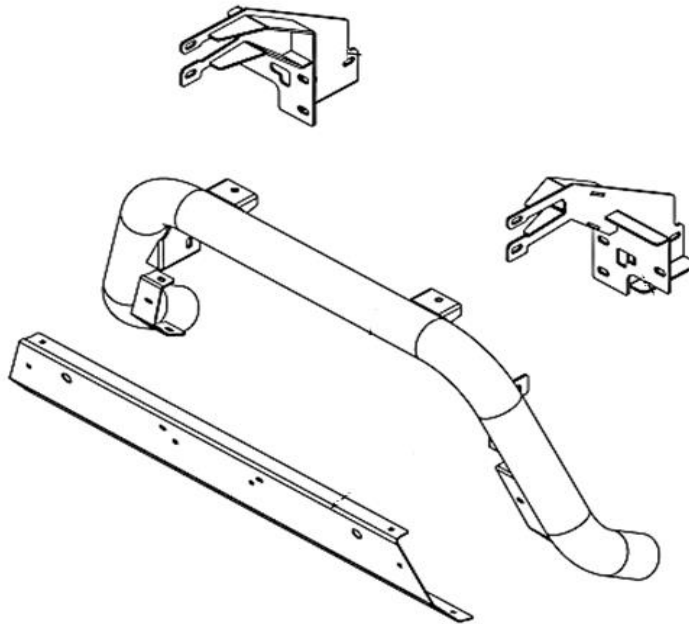

TORQUE SETTING OF FASTENER

Mounting bolts must be tightened to torque's specified following ;

Bolt Diameter (mm.)	Torque (Nm)	Torque (ft.lb)
M6	9	7
M8	22	16
M10	44	32
M12	77	57

FITTING PROCEDURE



1 Locate the vehicle in a suitable position.

2 Rest the Nudge bar on a surface that will not scratch the bar.

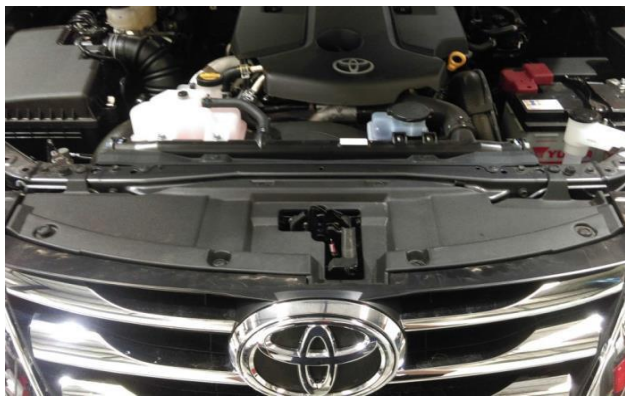

3 Open bonnet and remove the 8x screws to remove the grille cover plate.

4 Remove 4x screws retaining the grille and pull firmly to remove from vehicle

5 Remove 3x screws holding bumper & 2x screws



6 Remove screws and x screw from wheel arc.



7 Remove 9x screws from the bottom of the bumper bar.

8 Remove 6x screws from under body plastics & 2x screws.

FITTING PROCEDURE



9

Pull firmly on bumper to remove.

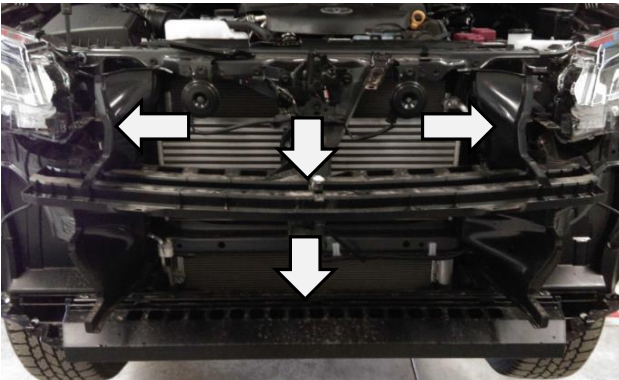

10

Remove 3x plastic air flow panels and discard.

11

Remove impact beam cover .

12

Remove impact beam by removing 4x

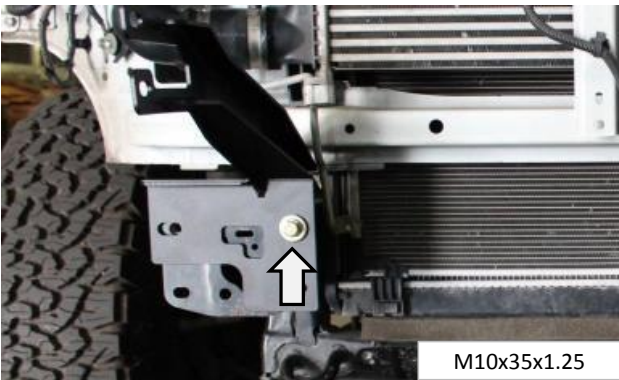

13

Place LH mounting bracket onto the chassis.

14

Secure with M10 bolt (M10x35x1.25), spring washer, flat washer and flange nut as shown.

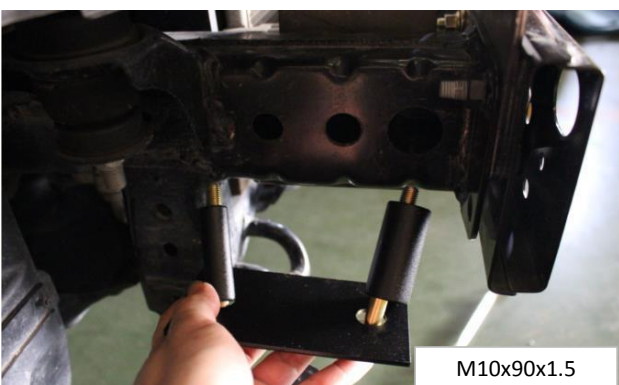

15

Place two M10 bolts (M10x90x1.5), spring washers and flat washers to 4 mm. spacer and place Ø16 mm. spacer tube and Ø25 mm. space tube to the bolts.

16

Place all to the chassis of vehicle and mounting bracket.

FITTING PROCEDURE

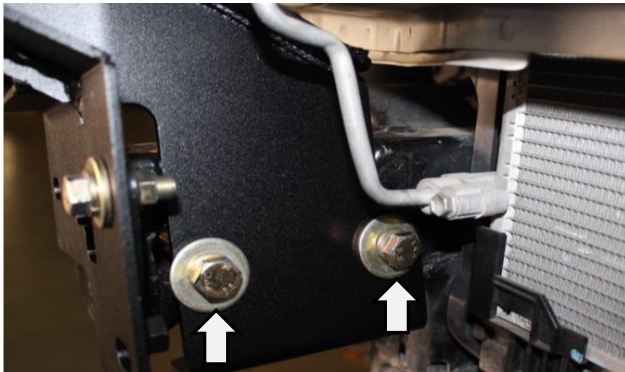

- 17** Secure with two M10 flat washers and hex nuts as shown.

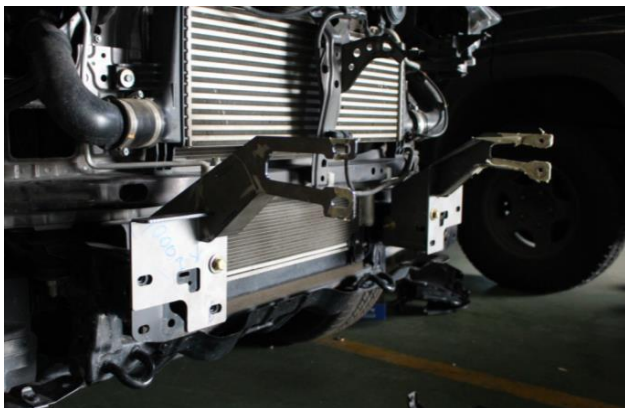

- 18** Repeat in step 13-17 for the opposite side.

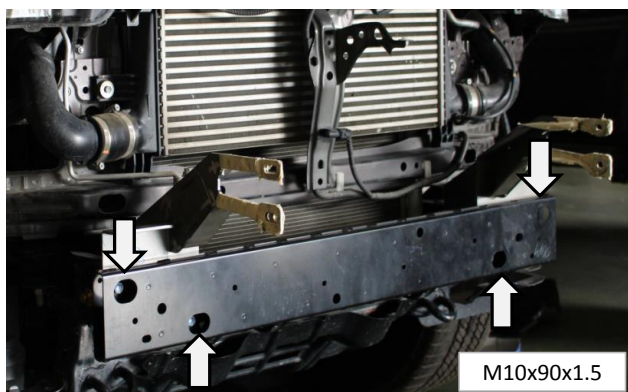

- 19** Re-fit the front intrusion beam by using four M10 bolts (M10x35x1.25), spring washer and flat washers as shown.



- 20** Re-fit the upper air guides to either sides of the vehicle as shown

FITTING PROCEDURE



- 21** Re-install the front bumper and place the chassis mount through the grill as shown.



- 22** Lift the Nudge bar fit to the chassis mount.

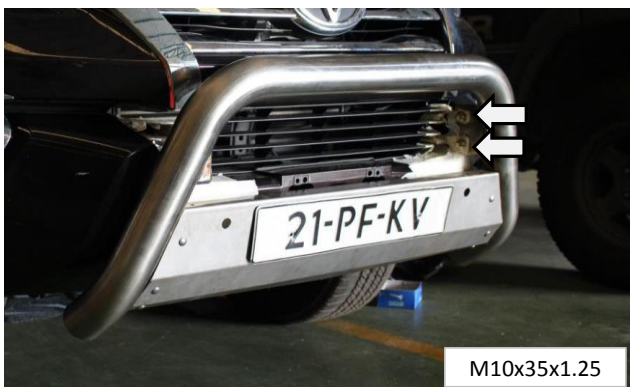

- 23** Secure the Nudge bar and chassis mounts by using two M10 bolts(M10x35x1.25), spring washers, flatwashers and flange nuts.