



ROCKRUNNER SPORT BAR

FITTING INSTRUCTIONS



MITSUBISHI TRITON DOUBLE CAB 2015-2019 ON

PK330MT19DC

Fitting Time : approx. 1 hours.



SPORT BAR SAFETY NOTICE:

INSTALLATION SHOULD ONLY BE DONE BY APPROPRIATELY QUALIFIED OR EXPERIENCED PERSONS IN ACCORDANCE WITH THESE INSTRUCTIONS.

IT IS THE RESPONSIBILITY OF THE INSTALLER TO ENSURE THAT THE PRODUCT IS CORRECTLY FITTED.

WARNING:

Do not attach Vehicle Frontal Protection System (VFPS) to the vehicle using anchorages not intended for this purpose. (e.g. engine mounting bolts)

Do not use this product for any vehicle make or model, other than those specified by the VFPS manufacturer.

Do not remove the plaque or label from the VFPS.

Do not modify the structure of the VFPS in any way.

The VFPS has been produced to provide continued functionality of parking sensors and other "driver assist" features as closely as possible to Original Equipment. However, as all possible road conditions and combination of other accessories fitted to the vehicle which may affect functionality characteristics cannot be anticipated, ***the driver remains responsible at all times for properly controlling the vehicle, monitoring all "driver assist" features and intervening where required to ensure the vehicle is safely operated.***

IMPORTANT INFORMATION:

Before installing the VFPS:

Check that all components, as listed in the assembly table, are available.

Thoroughly read all instructions.

This product or its fasteners must not be modified in any way.

These instructions are accurate as at the revision date and do not take into account any changes made by the vehicle manufacturer to vehicle design after the revision date or other accessories that are or have been fitted to the vehicle. PIAK cannot be held responsible for such changes and appropriate enquiries should be made before installation.

Before installing, inspecting and/or maintaining the VFPS, the work space should be safe and clear of fuel, debris, electrical or other components.

During installation:

It is the responsibility of the installer to confirm correct operation/clearance of all components.

All holes drilled shall have all burrs and swarf removed then coated with a suitable rust preventative paint.

Ensure that all hardware is fastened to torque list as detailed in these instructions.

MAINTENANCE AND CARE:

To ensure continued safety and correct operation of the product, the VFPS must be routinely inspected and regularly serviced (including bolt torque checked for correct tension) by an appropriately qualified or experienced person.

The high tensile fasteners supplied with this product were used to achieve the specified rating. If replacement of the fasteners is required, fasteners of the same rating and quality must be used.

If this VFPS is fitted with a hinged number plate bracket, extra care must be taken when returning back to public roads following the use of the winch or conducting a deep water crossing.

The driver must ensure that the number plate bracket is returned back to the down position allowing full visibility of the number plate when returning to public roads.

EQUIPMENT:

These safety products should, at a minimum, be used when fitting or working on the product.



Protective Glasses



Hearing Protection

Installation in accordance with these instructions and adherence to warnings will ensure compliance with relevant regulatory and safety standards as at the revision date.

Failure to adhere to these instructions may affect the roadworthiness of the vehicle or cause personal injury, death or damage to property.

BY USING THIS PRODUCT YOU ACKNOWLEDGE AND AGREE THAT TO THE EXTENT PERMITTED BY LAW PIAK WILL NOT ACCEPT LEGAL OR OTHER LIABILITY FOR ANY LOSS, INJURY OR DAMAGE CAUSED BY INCORRECT OR INAPPROPRIATE INSTALLATION OR USE OF THE PRODUCT.

TOOLS REQUIRED

1. Socket wrench
2. Combination Wrench
3. Marker
4. Drill \varnothing 9 and \varnothing 10 mm.
5. Tape
6. Wiring harness

PARTS LIST



Important : Check contents of fitting kit before commencing fitment and report any discrepancies.

Sport Bar			
Item	Component Name	Q'ty	Remarks
1	Sport Bar L/R	2	
2	Mounting Bracket Sport Bar	2	
3	Button Head Bolt M10x1.5x30	4	
4	Flat Washer M10 OD27	4	
5	Spring Washer M10	4	
6	Button Head Bolt M8x1.25X35	10	
7	Flange Nut M8x1.25	4	
8	Flat Washer M8 OD16	8	
9	Flat Washer M8 OD22	6	
10	Spring Washer M8	10	
11	Plate Nut M8x1.25	6	
Box Center			
Item	Component Name	Q'ty	Remarks
12	Box Center	1	
13	Lock Sport Bar	2	
14	Button Head Bolt M6x1.0x25	4	
15	Flat Washer M6 OD14	4	
16	Spring Washer M6	4	
17	Cage Nut M6x2T	4	

COMPONENTS OVERVIEW

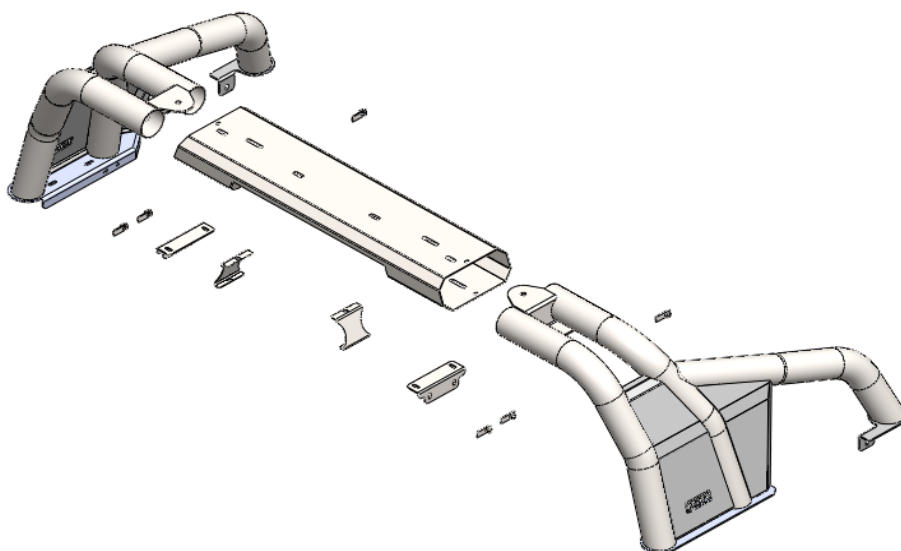

TORQUE SETTING OF FASTENER

Mounting bolts must be tightened to torque's specified following ;

Bolt Diameter (mm.)	Torque (Nm)	Torque (ft.lb)
M6	9	7
M8	22	16
M10	44	32
M12	77	57

FITTING PROCEDURE



- 1 Vehicle before installation of Rockrunner Sport Bar .

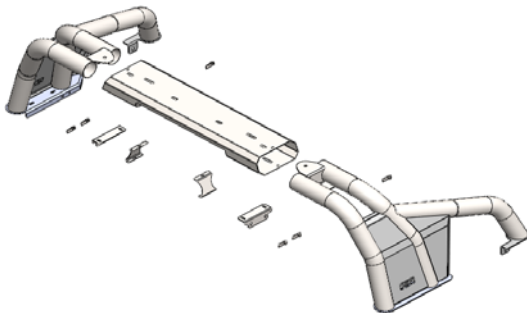

- 2 Place Rockrunner Sport Bar face down on a surface that will not scratch the bar.

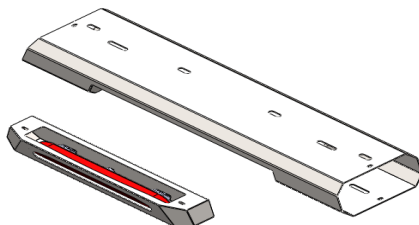

- 3 Remove the light box from the box center.

FITTING PROCEDURE

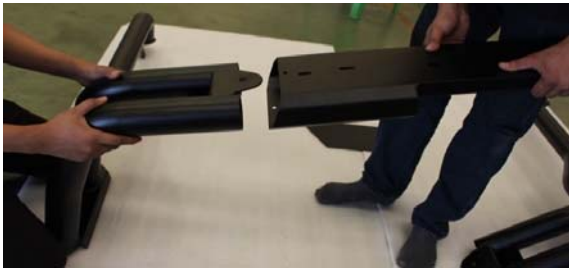

4

Install the sport bar left and sport bar right to the blox center



5

Attach top side the sport bar left and sport bar right to the blox center with two M10x1.5x30 Button Head Bolt , two flat washer M10 OD27, two spring washer M10.
Do the same on both sides.



6

Attach Bottom side the sport bar left and sport bar right to the blox center with two M10x1.5x30 Button Head Bolt , two flat washer M10 OD27, two spring washer M10.
Do the same on both sides.

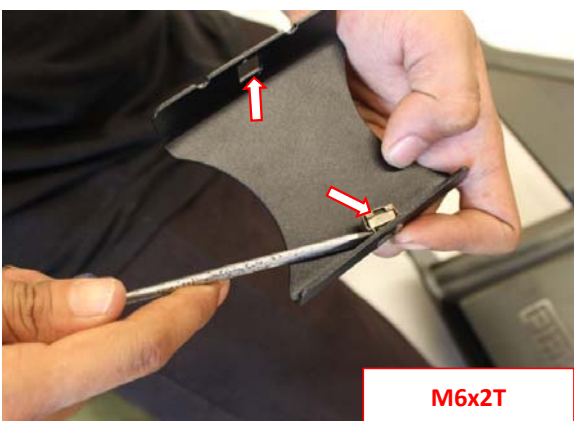

7

Assembly Two cage nut M6x2T to the lock sport bar both hole top and bottom.
Do the same on both sides.

FITTING PROCEDURE



- 8** assembly lock sport bar to the box center .
Do the same on both sides.

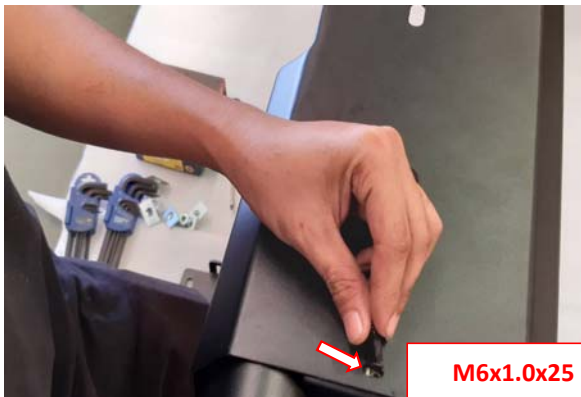

- 9** Attach top side the box center to the lock sport bar with two M6x1.0x25 button head bolt, flat washer M6 OD14, spring washer M6.
Do the same on both sides.



- 10** Attach top side the box center to the lock sport bar with two M6x1.0x25 button head bolt, flat washer M6 OD14, spring washer M6.
Do the same on both sides.



- 11** Lift the rockrunner sport bar place on the mitsubishi triton.
Adjust the distance rockrunner sport bar appropriately with Pick-up edge.

FITTING PROCEDURE



- 12** brace Mounting Bracket Sport Bar to the Pick-up edge.
Do the same on both sides.



- 13** Mark position at front Pick-up edge under base sport bar for drill .
Do the same on both sides.



- 14** Mark position at rear Pick-up edge under base sport bar for drill .
Do the same on both sides.



- 15** drill the Pick-up edge at position mark both front and rear with Drill Ø 9mm.
Do the same on both sides.

FITTING PROCEDURE



- 16** Hole position after drilling.
the same on both sides with hole \varnothing 9mm.

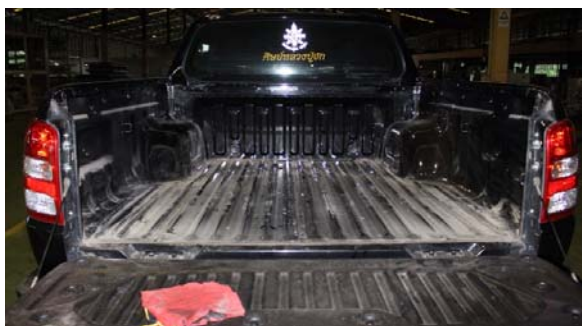

- 17** Remove the maxliner from the mitsubishi triton



- 18** Drill holes for wearing brake lights with drill \varnothing 10 mm.



- 19** Attach tree plates Nut M8x1.25 to the inner edge of the rim to match the hole drilled using glue 3M. Do the same on both sides.

FITTING PROCEDURE



20 Remove the rear lights for brake lights.



21 Connect the end of the power cable to the original brake light



22 The brake line along the pick-up line.
Assemble the rear light to the same place.



23 The brake line along the pick-up line.

FITTING PROCEDURE



24

Pull out the end of the brake light set at the hole drilled on the front of the pickup truck.

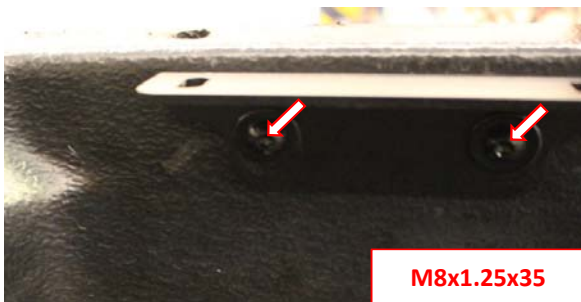

25

Assembling Mounting Bracket Sport Bar to the pickup edge By Using two Button Head Bolt M8x1.25x35, flat Washer M8 OD22, spring washer.



26

Raise the rockrunner sport bar extended , place it on the edge of the pickup truck again, then wire the wires from the hole under the base of the sports bar to the center box.



27

Connect the brake cable to the brake light unit and the light box.

Assemble the light box to the middle box as before.

FITTING PROCEDURE



- 28** Install base sport bar to the Mounting Bracket Sport Bar With two Button head bolt M8x1.25x35 , Four flat washer M8 OD16 , two spring washer M8 .
Do the same on both sides.



- 29** Install bracket rear sport bar to Pick-up edge With button head bolt M8x1.25x35 , flat washer M8 , spring washer M8 .
Do the same on both sides.



- 30** Sports bar after installation on the car is completed.