



PIAK SIDE RAILS

FITTING INSTRUCTIONS



FORD RANGER 2022
FORD EVEREST 2022
PK402FR22/FE22

Fitting Time : approx. 1 hours



SIDE RAILS SAFETY NOTICE:

INSTALLATION SHOULD ONLY BE DONE BY APPROPRIATELY QUALIFIED OR EXPERIENCED PERSONS IN ACCORDANCE WITH THESE INSTRUCTIONS.

IT IS THE RESPONSIBILITY OF THE INSTALLER TO ENSURE THAT THE PRODUCT IS CORRECTLY FITTED.

WARNING:

Do not attach the side rails to the vehicle using fasteners other than provided.

Do not use this product for any vehicle make or model, other than those specified.

Do not remove the plaque or label from the side rails

Do not modify the structure of the side rails in any way.

IMPORTANT INFORMATION:

Before installing the PIAK Products:

- Check that all components, as listed in the assembly table, are available.
- Thoroughly read all instructions.

This product or its fasteners must not be modified in any way.

These instructions are accurate as at the revision date and do not take into account any changes made by the vehicle manufacturer to vehicle design after the revision date or other accessories that are or have been fitted to the vehicle. PIAK cannot be held responsible for such changes and appropriate enquiries should be made before installation.

Before installing, inspecting and/or maintaining the PIAK Products, the work space should be safe and clear of fuel, debris, electrical or other components.

During installation:

- It is the responsibility of the installer to confirm correct operation/clearance of all components.
- All holes drilled shall have all burrs and swarf removed then coated with a suitable rust preventative paint.
- Ensure that all hardware is fastened to torque list as detailed in these instructions.

MAINTENANCE AND CARE:

To ensure continued safety and correct operation of the PIAK Products. It must be routinely inspected and regularly serviced (including bolt torque checked for correct tension) by an appropriately qualified or experienced person.

The high tensile fasteners supplied with this product were used to achieve the specified rating. If replacement of the fasteners is required, fasteners of the same rating and quality must be used.

EQUIPMENT:

These safety products should, at a minimum, be used when fitting or working on the product.



Protective Glasses



Hearing Protection

Installation in accordance with these instructions and adherence to warnings will ensure compliance with relevant regulatory and safety standards as at the revision date.

BY USING THIS PRODUCT YOU ACKNOWLEDGE AND AGREE THAT TO THE EXTENT PERMITTED BY LAW PIAK WILL NOT ACCEPT LEGAL OR OTHER LIABILITY FOR ANY LOSS, INJURY OR DAMAGE CAUSED BY INCORRECT OR INAPPROPRIATE INSTALLATION OR USE OF THE PRODUCT.

TOOLS REQUIRED

1. Torque , Socket wrench
2. 8 mm. drill bit
3. Open spanner

Part Listing

⚠ Important : Check contents of fitting kit before commencing fitment and report any discrepancies.

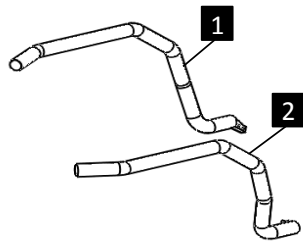
Side Rail			
Item	Component Name	Q'ty	Remarks
1	Side Rail (RH)	1	
2	Side Rail (LH)	1	

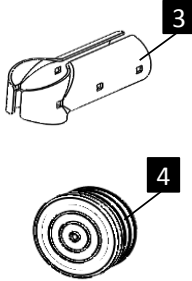
Fasteners				
Item	Component Name	Q'ty	Remarks	
3	Side Rail Clamp (2.5") 85 degree (LH/RH)	2		
4	Rubber Cover 2.5"	2		
5	Botton Head Bolt M8x85x1.25	6		
6	Flat Washer M8 OD16	12		
7	Nyloc Nut M8x1.25	6		
8	Hex Bolt M8x35x1.25	4		
9	Spring Washer M8	4		
10	Flat Washer M8 OD22	8		
11	Flange Nut M8x1.25	4		

Torque Setting of Fastener

Mounting bolts must be tightened to torque's specified following ;

Bolt Diameter (mm.)	Torque (Nm)	Torque (ft.lb)
M6	9	7
M8	22	16
M10	44	32
M12	77	57

COMPONENTS OVERVIEW

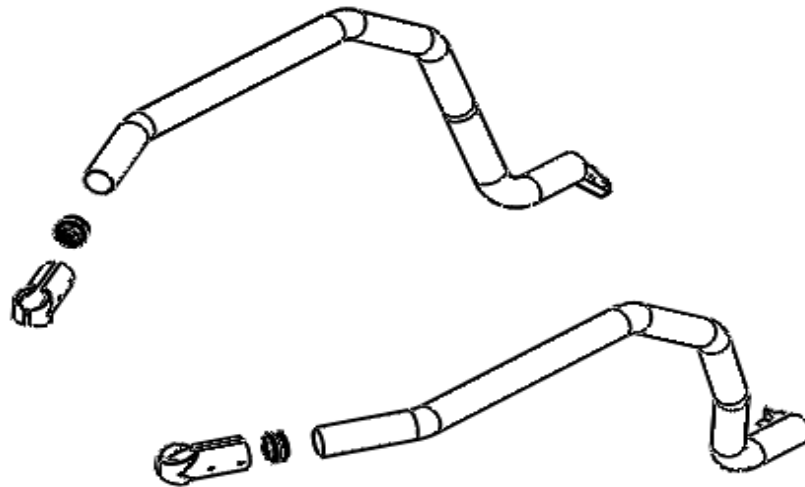

Fitting Procedure



1

Locate the vehicle in a suitable area. Remove any existing steps installed on vehicle and discard.



2

Remove head side step to install side rails and retain the four M8 bolts, washers and nuts .

Fitting Procedure



- 3 If it exists with a pair of pliers break off the step in-fill piece and file of any sharp edges.



- 4 Connect the side rail into the side step.

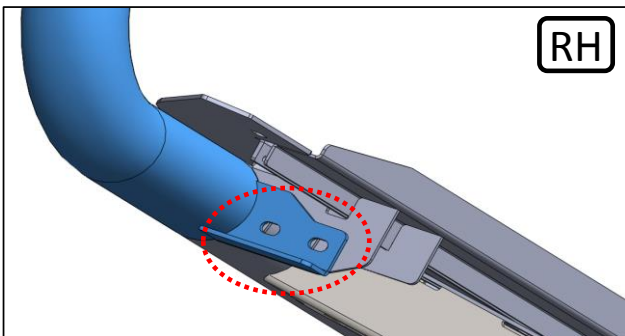

- 5 Secure the side rail to the side step with a M8 hex bolt, M8 flat washer and M8 flange nut removed from the side step.

Fitting Procedure



6 Clamp the side rail to the bullbar.



7 Drill holes through the side rail using the holes in the side rail as a guide.

*Drill at loop of bumper.



8 Drill three holes through the side rail using the holes in the side rail as a guide.

*Drill at side rails.



9 Secure with three M8 boltsbutton head, flat washers and nyloc nut.

Tighten all bolts with the correct torque.

Repeat in step 2-9 for the LH side

