



ELITE REAR TOW BAR WITH SIDE PROTECTION

FITTING INSTRUCTION



FORD RANGER

2011-2018

PK204FR11E/FR15E/FR18E

Fitting Time : approx. 1.5 hours



TOW BAR SAFETY NOTICE:

INSTALLATION SHOULD ONLY BE DONE BY APPROPRIATELY QUALIFIED OR EXPERIENCED PERSONS IN ACCORDANCE WITH THESE INSTRUCTIONS.

IT IS THE RESPONSIBILITY OF THE INSTALLER TO ENSURE THAT THE PRODUCT IS CORRECTLY FITTED.

WARNING:

Do not attach the tow bar to the vehicle using fasteners other than provided.

Do not use this product for any vehicle make or model, other than those specified.

Do not remove the plaque or label from the tow bar.

Do not modify the structure of the tow bar in any way.

This product has been produced to provide continued functionality of parking sensors and other "driver assist" features as closely as possible to Original Equipment. However, as all possible road conditions and combination of other accessories fitted to the vehicle which may affect functionality characteristics cannot be anticipated, the driver remains responsible at all times for properly **controlling the vehicle, monitoring all "driver assist" features and intervening where required to ensure the vehicle is safely operated.**

This product is for towing purposes only. Exceeding the specified towing capacity of the vehicle is dangerous and can void vehicle warranties. Please always refer to the vehicle owner's manual or the manufacturer for towing capacity specifications.

IMPORTANT INFORMATION:

Before installing the product:

Check that all components, as listed in the assembly table, are available.

Thoroughly read all instructions.

This product or its fasteners must not be modified in any way.

These instructions are accurate as at the revision date and do not take into account any changes made by the vehicle manufacturer to vehicle design after the revision date or other accessories that are or have been fitted to the vehicle. PIAK cannot be held responsible for such changes and appropriate enquiries should be made before installation.

Before installing, inspecting and/or maintaining the product, the work space should be safe and clear of fuel, debris, electrical or other components.

During installation:

It is the responsibility of the installer to confirm correct operation/clearance of all components.

All holes drilled shall have all burrs and swarf removed then coated with a suitable rust preventative paint.

Ensure that all hardware is fastened to torque list as detailed in these instructions.

MAINTENANCE AND CARE:

To ensure continued safety and correct operation of the product, the product must be routinely inspected and regularly serviced (including bolt torque checked for correct tension) by an appropriately **qualified or experienced person**. Pull Pins and "R" clips must be regularly checked for proper installation. Replace any worn or defective parts.

Tow ball mounts, tongues or lugs should be removed when not actually towing so as to produce an unobscured view of the vehicles registration plate, and to also provide maximum available departure angle.

It is recommended that the tongue, Pull Pin and R-clip are removed when not towing and stored in a safe, clean and dry place.

PIAK recommends that you check your tow ball to ensure that it complies with the Australian Standard AS 4177.2.

EQUIPMENT:

These safety products should, at a minimum, be used when fitting or working on the product.



Protective Glasses



Hearing Protection

Installation in accordance with these instructions and adherence to warnings will ensure compliance with relevant regulatory and safety standards as at the revision date.

Failure to adhere to these instructions may affect the roadworthiness of the vehicle or cause personal injury, death or damage to property.

BY USING THIS PRODUCT YOU ACKNOWLEDGE AND AGREE THAT TO THE EXTENT PERMITTED BY LAW PIAK WILL NOT ACCEPT LEGAL OR OTHER LIABILITY FOR ANY LOSS, INJURY OR DAMAGE CAUSED BY INCORRECT OR INAPPROPRIATE INSTALLATION OR USE OF THE PRODUCT.

TOOLS REQUIRED

1. Metric socket and spanners
2. Torque wrench
3. Phillips and flat head screw driver
4. Masking Tape

PARTS LIST



Important : Check contents of fitting kit before commencing fitment and report any discrepancies.

Item	Component Name	Q'ty	Remarks
1	Elite Rear Tow Bar With Side Protection		
Fitting Kit			
Item	Component Name	Q'ty	Remarks
2	D Shackle 3/8"	2	
3	Sensor plug 28 mm.	4	
4	Hex Bolt M12x1.75x35	5	
5	Hex Bolt M12x1.5x35	8	
6	Plate Nut M12x1.5	8	
7	Spring Washer M12	13	
8	Flat Washer M12OD33	13	

COMPONENTS OVERVIEW

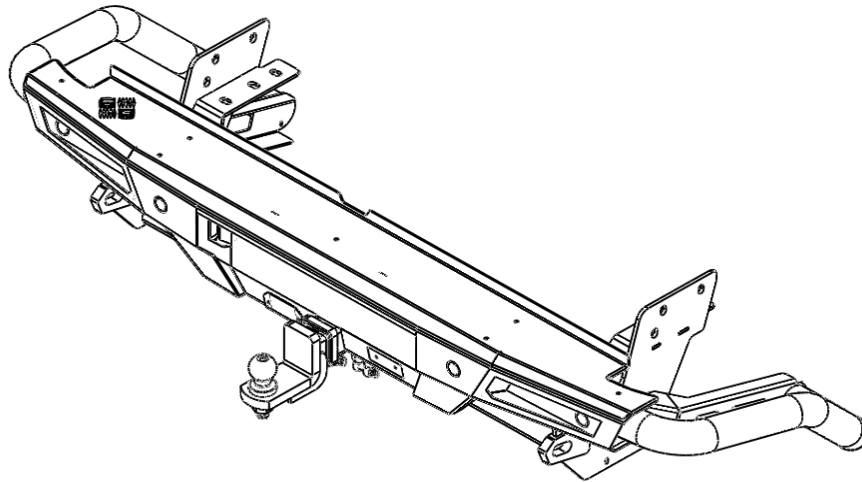

TORQUE SETTING OF FASTENER

Mounting bolts must be tightened to torque's specified following ;

Bolt Diameter (mm.)	Torque (Nm)	Torque (ft.lb)
M6	9	7
M8	22	16
M10	44	32
M12	77	57

FITTING PROCEDURE



1 Locate the vehicle in a suitable position.



2 Remove the original bumper from vehicle and place on a soft surface.

3 Unclip the wiring looms coming from behind the bumper bar.

4 Carefully remove the bumper from the vehicle.
If unsure about bumper removal refer to the workshop manual



5 Carefully remove parking sensors mount bracket from bumper making sure not damage the bracket in the process.

*****Note the location of each parking sensor.*****

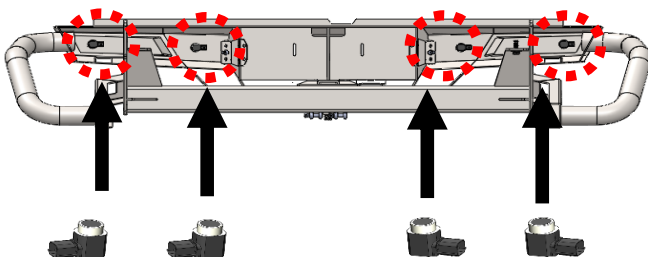

6 Re - install the parking sensor surround and parking sensors to the rear bar.

FITTING PROCEDURE

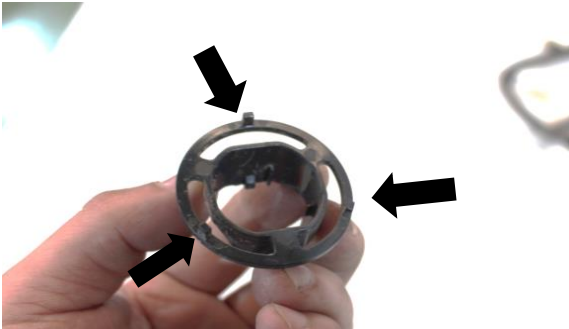

7

Cut three Plastic Sensor housing 3 mm gap as shown.

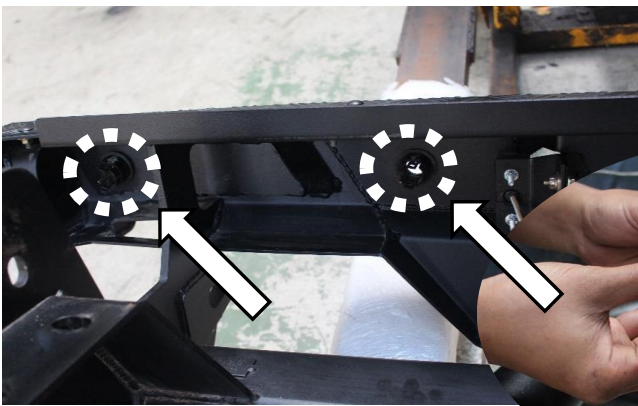

8

Re - install the parking sensor surround brackets and parking sensors brackets to the rear bar.

*****Repeat for the opposite side.*****



RH

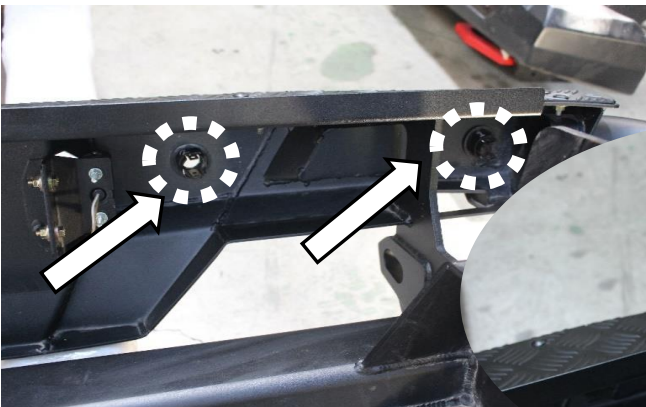

9

Re - install the parking sensor surround brackets and parking sensors brackets to the rear bar.

*****Repeat for the opposite side.*****



LH

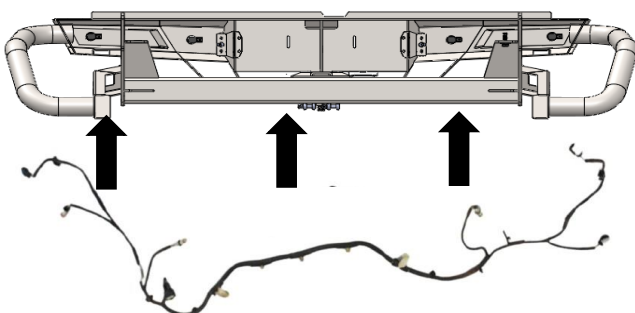

10

Re - install the wiring into parking sensors surround and parking sensors to the rear bar.

FITTING PROCEDURE



11 Lift the rear bar onto the chassis of vehicle.

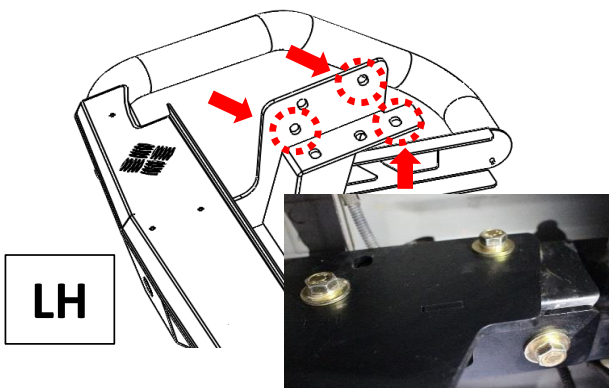

12 Secure with three M12 bolts (M12x35x1.75), spring washers and flat washers beside the LH mounting bar as shown.

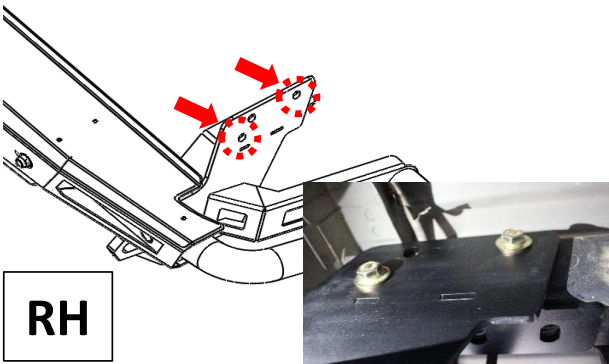

13 Secure with two M12 bolts (M12x35x1.75), spring washers and flat washers beside the RH mounting bar as shown.

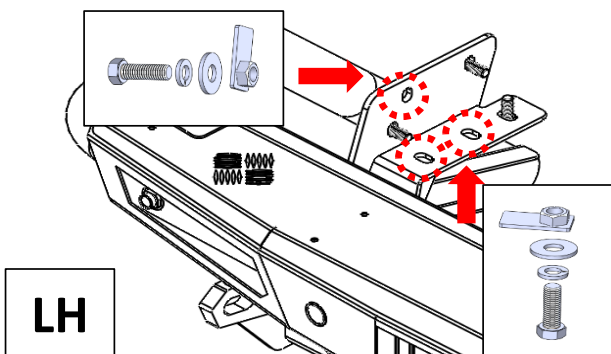

14 Secure with three M12 bolts (M12x35x1.5), spring washers, flat washers and plate nut beside the LH mounting bar as shown.

FITTING PROCEDURE

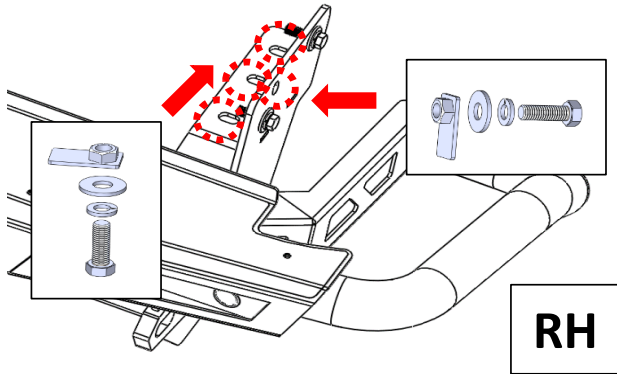

- 15** Secure with four M12 bolts (M12x35x1.5), spring washers, flat washers and plate nut beside the RH mounting bar as shown.

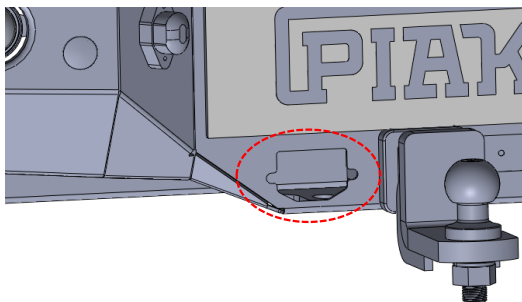

- 16** Location for installing trailer plug the position as shown .

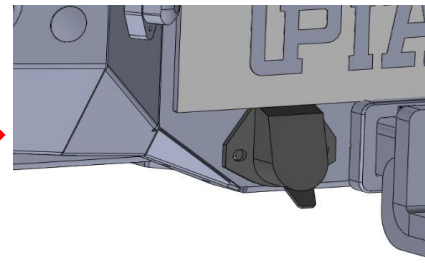
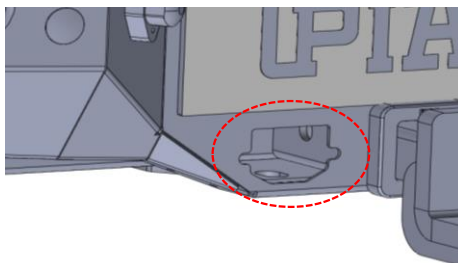
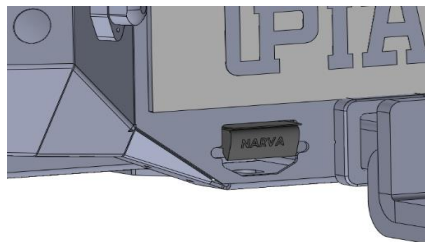
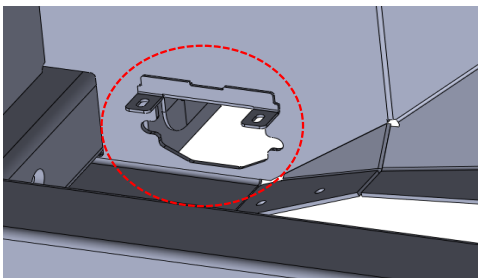

FITTING PROCEDURE

