

Installation Guide

Rear Sway Bar

Suits: V.A.G. A5(PQ35) AWD + FWD PLATFORM

(Always refer to the current catalogue for complete application listings)

N.B: These instructions should be used in conjunction with the workshop manual

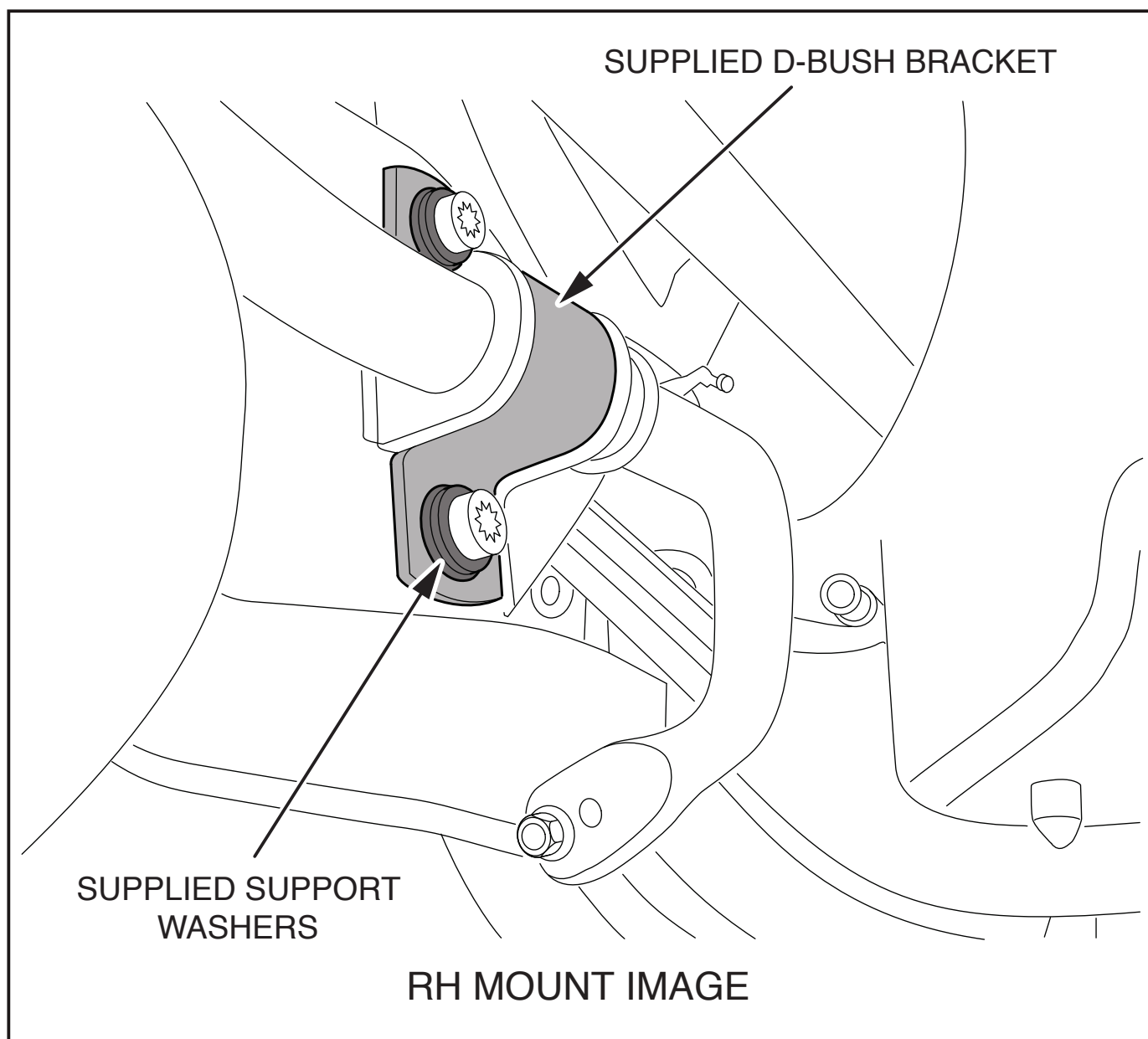

NOTE: Caution must be taken when installing the BWR21XZ 24mm rear sway bar to the vehicle without fitting the front BWF19 series or BWF20 series front swaybars as the balance of the vehicle will be altered. This may cause the vehicle to oversteer during sudden braking/steering manoeuvres.

N.B: It is recommended that a licenced workshop or trades person carry out the above procedure and that workshop manual and relevant safety procedures are followed in addition to the above.

Installation Guide

Alloy Lateral Lock Kit

Z 5160

(Always refer to the current catalogue for complete application listings)

Alloy high performance lateral locks are designed to maintain Swaybar centralization.

1. Once you have your Swaybar in position and central with links attached, attach the lateral locks next to the mounting bush (leave approx 3-4mm gap). This can be either side of the mounting bush but its best to aim for the most accessible area on the Swaybar. If there is little room to physically tighten the lateral locks, it may be best to mark your Swaybar then remove from vehicle then attach the lateral locks prior to fitment.
2. Tighten the lateral lock bolts down evenly and use mild force to secure.
Note : Please don't over tighten.
3. After test driving the vehicle, recheck Swaybar position and adjust lateral locks if necessary.

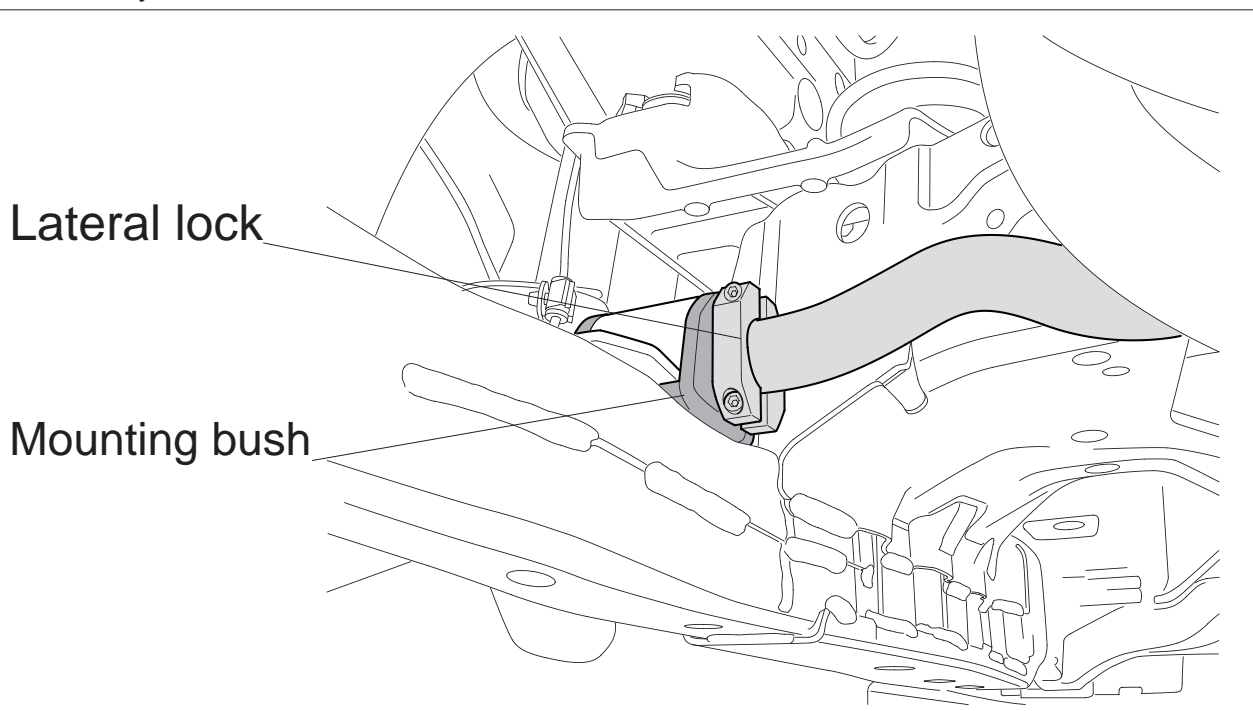

N.B: It is recommended that a licenced workshop or trades person carry out the above procedure and that workshop manual and relevant safety procedures are followed in addition to the above.

GREASE FREE TECHNOLOGY



Introducing Grease Free Technology Bushings

Bushings supplied in this kit feature not only the latest synthetic elastomer bushing material technology but a high performing PTFE inner lining boasting an extraordinary low coefficient of friction. This inner lining eliminates the need to lubricate the bushing on installation and therefore makes these bushing 'grease free'!

Superior friction management

- reduces heat build up known to deform or degrade bushing over time
- dramatically reduces high frequency noises (squeaking)
- eliminates the need for maintenance/ greasing

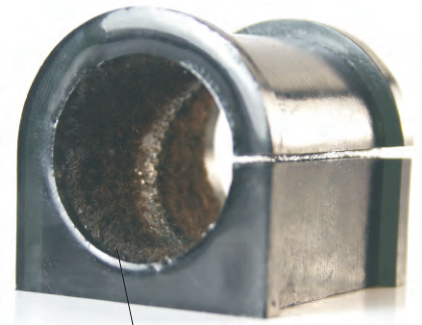

PTFE LINING

Installation tip

Ensure a clean mating surface when installing these bushings for optimum performance!

Frequently Asked Questions

What happens if I do apply grease to the lining?

Don't stress, simply wipe away as much of the lubricant from the surface as possible and install. Adding grease does not further improve the bushings function/ performance nor does traces of lubricant impede the function/ performance.

Do I need to grease other areas of the bushing?

Simply, no! Unless the kit is supplied with a grease packet and lubrication instructions, no other area of the bushing requires lubrication.

Do these bushings require maintenance?

Significant improvements in grease retention within bushing design has dramatically improved over recent years, however this new grease free technology does away with all lubricants and subsequent or periodical maintenance.

Is this technology available across the entire range?

For the most up to date offering of grease free technology bushings visit the website!

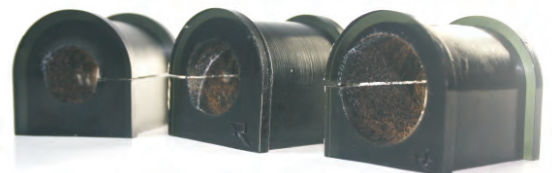
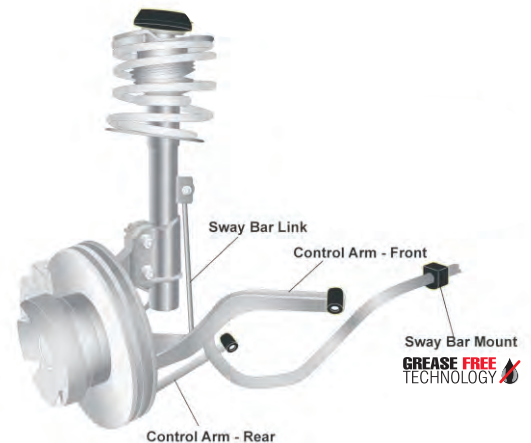

FRICION FREE | SILENT OPERATION | MAINTENANCE FREE