

Front Sub-frame to Chassis Bushings

N.B: This instruction sheet should be used in conjunction with the workshop manual and proper safety procedures followed.

- Raise vehicle evenly and safely support with stands.

Never rely on a Jack only.

- Proceed to remove front wheels and un-bolt control arms from hubs.

- Un-bolt and remove sub-frame. The original bushings can be pushed out with a hammer and chisel.

- Push in new supplied bushings **91966** and **91967** in to clean sub-frame - refer image below.
- Apply small amount of grease to bushing internal diameter. Place supplied washer between vehicle floor and bushing 91966.
- Re-fit sub-frame to vehicle. A wheel alignment is recommended after install.

Application - Nissan Xtrail - T31
- Nissan Dualis J Series

Always refer complete catalogue listing

Contents - 2x bushing 91966
- 2x bushing 91967
- 2x steel tubes 30x18.5x140
- 2x steel washers 46x20.5x2
- Grease

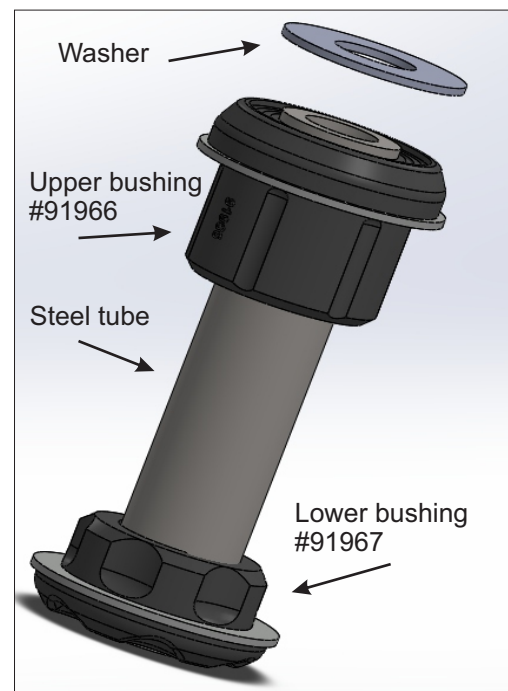

N.B: It is recommended that a licenced workshop or tradesperson carry out the above procedure and that workshop manual and relevant safety procedures are followed in addition to the above.