

Fitting Instructions #2821IS

Mazda RX7 Series VI,VII,VIII (FD1031) 4/1992 – 2002

Control Arm Upper-Inner Kit (Front)



Note: Polyurethane bushings must be fitted to both sides of the vehicle.

SPF2821K – standard replacement kit

SPF2821XK – camber +/- both sides, approx 0.5 degree change (has 4 bushes & 4 offset tubes)

- Wheel-align the vehicle before the job is started and note settings.
- With the vehicle on jack stands, remove the front upper control arms.
- With the use of a hydraulic press and suitable pressing tool, remove the factory bushes.
- Clean housing areas to remove any old original bushing materials.
- Using the appropriate pressing tools support the control arm and press in the new bushes according to the orientation shown in Figure 1.
- Apply the grease supplied to the bore of the bush and the outside of the steel crush tube and then, push the crush tube in according to your desired settings (Refer to Table).
- Refit the front upper control arms to the car, making sure you tighten the bolts with the arm held at 90 degrees to the mounts to give you the maximum camber offset.
- Ensure that all fasteners are torque to manufacturer's specification and carry out a wheel alignment.

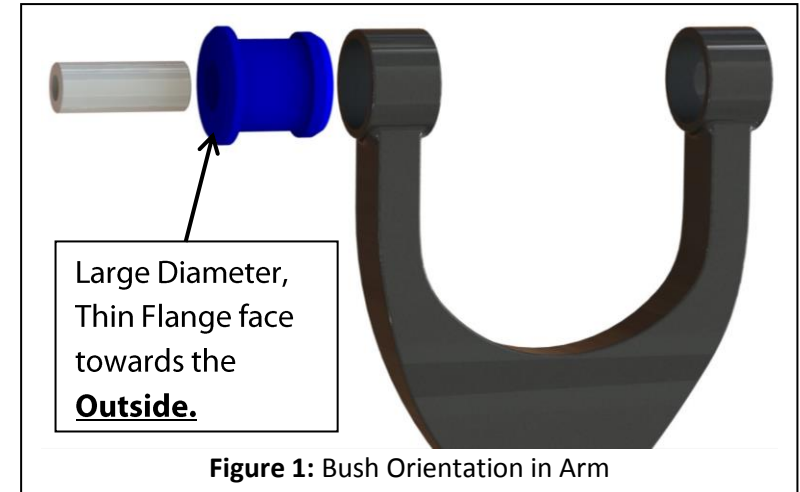

Figure 1: Bush Orientation in Arm

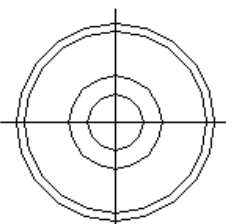
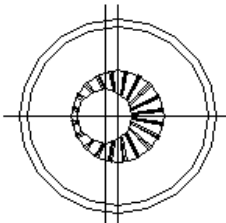
As Viewed from LHS Rear	
	SPF2821
	SPF2821XK

Table 1: Illustration of Camber Settings