

# Fitting Instructions #TRC0043IS

Toyota Fortuner 2015-On

## Centre Bearing Kit



- This kit helps to reduce driveline vibration in a 2" lifted vehicle
- Remove original centre bearing fasteners;
- Fit the kit as per picture below – 10mm spacer on top, and the supplied fasteners on the bottom;
- Drop loctite on the thread and tighten the bolt to manufacturer's specification;
- Remaining spacers and fasteners are used to space down the safety loop to gain clearance on the drive shaft, which are fitted in the same orientation as the centre bearing.

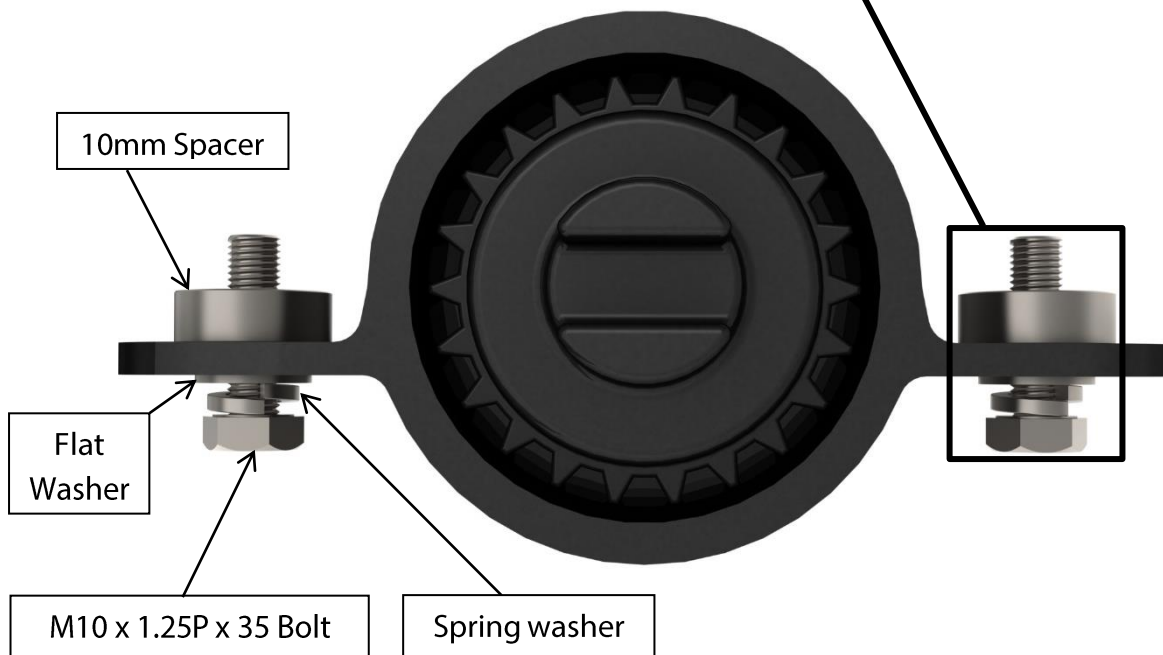
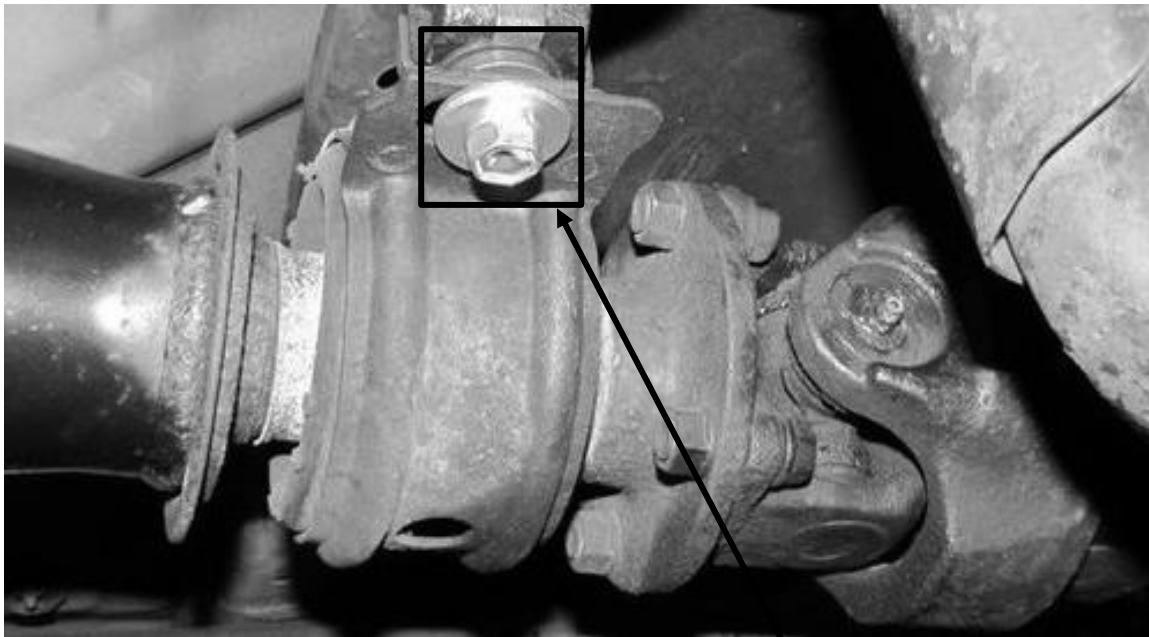

### Kit Contents

4 x M10x1.25Px35 Bolt;      4 x M10 Spring Washer;      4 x M10 Flat Washer;      4 x 10mm Spacer