

Fitting Instructions #5191IS

Dodge Hellcat

Differential Pinion Mount Bush kit

Note it is recommended that the rear bushes be replaced with SPF5165K

- With the vehicle on a hoist, remove the differential Centre from the vehicle
- Discard the OE washers and remove original shell parts from the housing with suitable press tools.
- Clean housing areas to remove any old original bushing materials ensuring the bores are smooth and free of burrs;
- Grease the bore of the housing and using the image as a guide insert "5191" bushing into housing.
- Grease the bore of the bush and using multigrips or similar press crush tubes into the bush.
- Fit new washers to the upper and lower position and offer assembly back into sub frame
- Ensure that all fasteners are torqued to manufacturer's specification.

Figure 01 – Front diff bushing installation

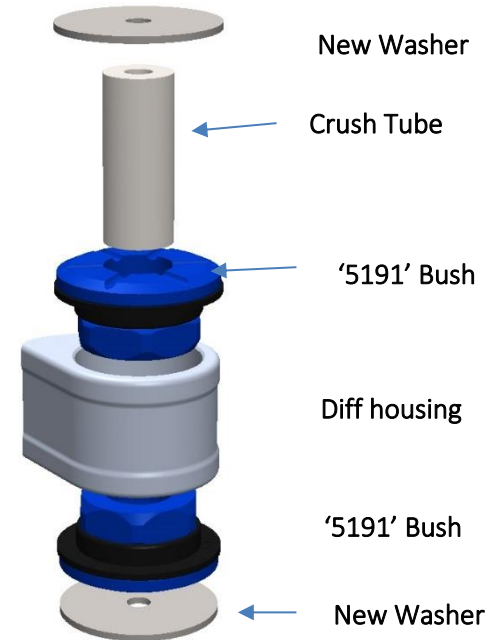

Exploded view of bushing installation

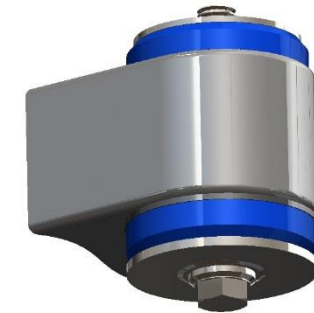

Figure 02 –Assembly