

Fitting Instructions #3886IS

Nissan 370Z

Control Arm Front Bushing

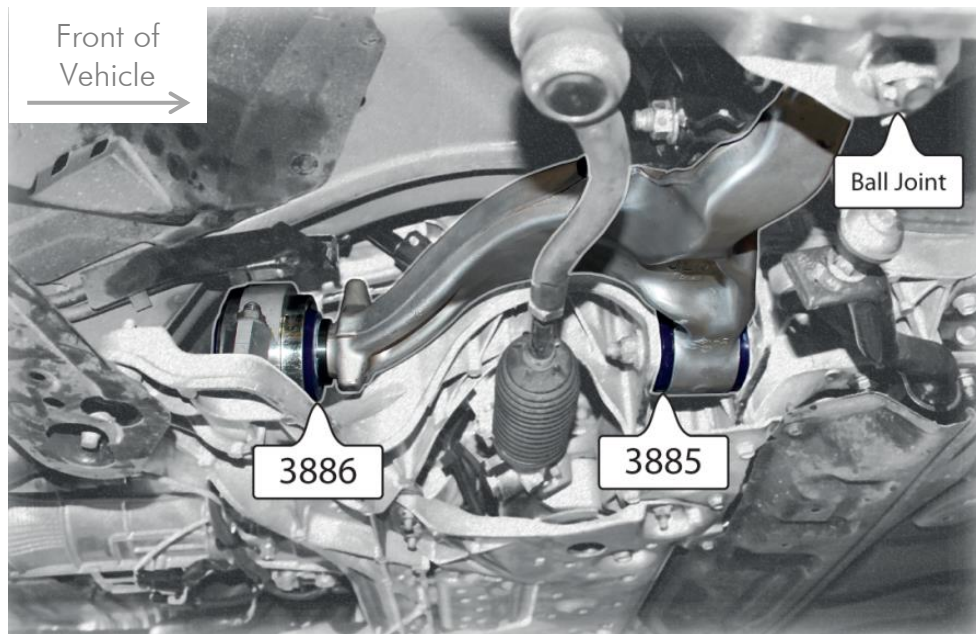

- With the vehicle on jack stands/hoist, remove the control arms;
- Use a hydraulic press to remove the OE bushes and the shell part from the arms and brackets;

Control Arm Front Bush:

- Apply the grease supplied to the housing bore and to the bush outer diameter surfaces;
- Install the new '3885' bushes into the front bush housing as shown in Figure 01 and Figure 02;
- Using the grease supplied, liberally apply it to the polyurethane bore of the bush, the outside of the steel crush tube, and then push the tube into the bush, Figure 02;

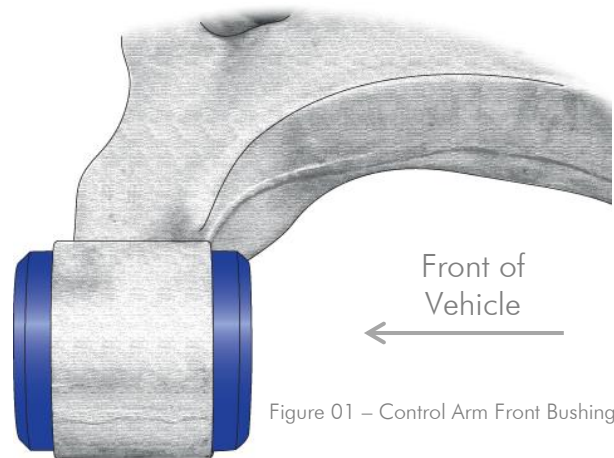

Figure 01 – Control Arm Front Bushing

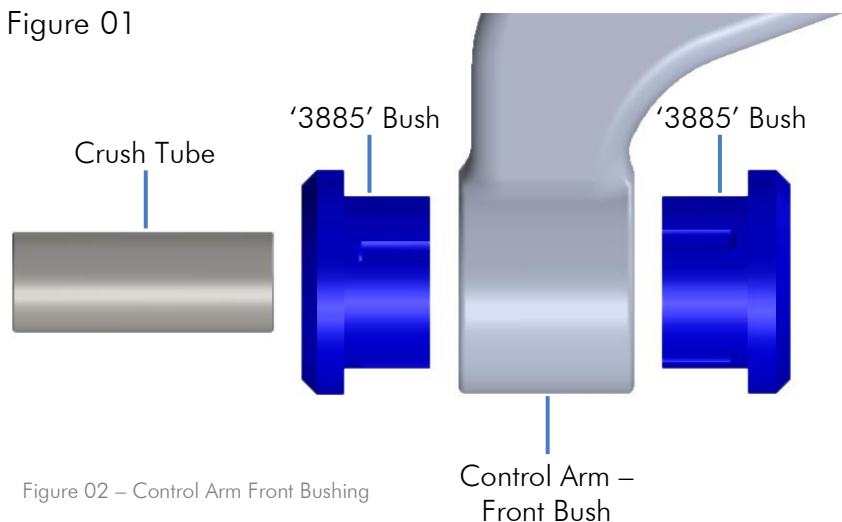

Figure 02 – Control Arm Front Bushing

Control Arm Rear Bush:

- Install the new aluminium sleeve to the control arm peg, Figure 03 and Figure 04;
- Press the new '3886' bush into the original brackets, noting that the step on the shell should face the control arm and the offset should be positioned towards the wheel. Press the bush plus bracket against the arm peg with the sleeve installed. See Figure 03, Figure 04 and Figure 05 for details;

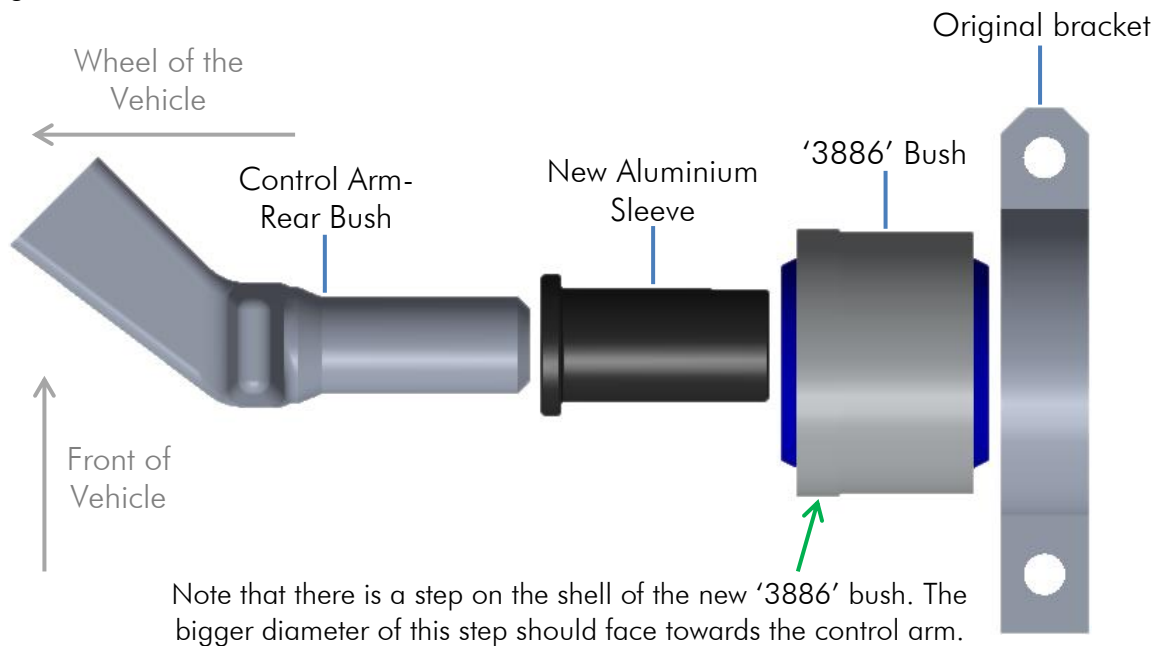

Figure 03 – LHS Control Arm Rear Bushing – Top View

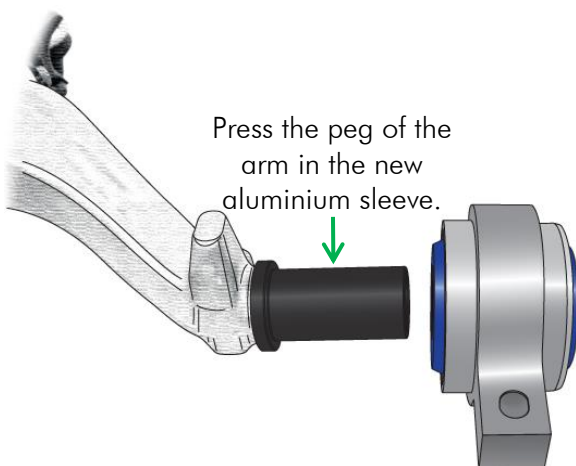

Figure 04 – RHS Control Arm Rear Bushing

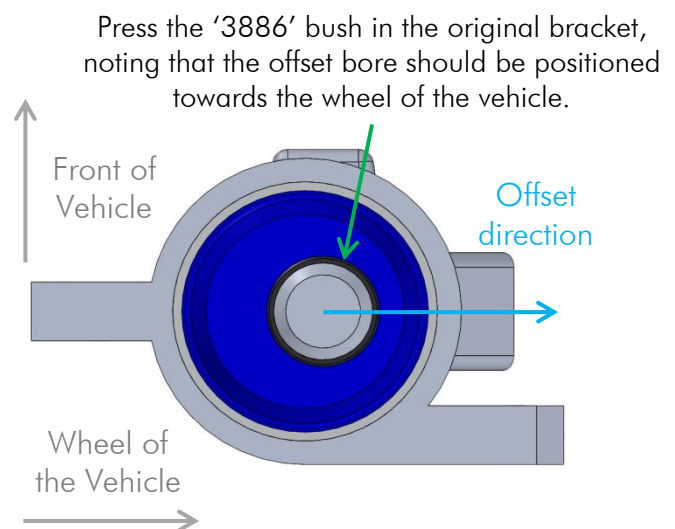

Figure 05 – RHS Control Arm Rear Bushing Offset direction – View from Rear of the vehicle

- Refit the control arms to the vehicle and tighten all bolts to the manufacturer's torque specifications;
- Re-assembly the rest of the car. Carry out a wheel alignment.

Note: Polyurethane bushings must be fitted to both sides of the vehicle. This kit should be installed by a Qualified Motor Mechanic.