

Fitting Instructions #4189IS

Nissan Pulsar N16 (07/2000-11/2005)

Suspension Link Bushing (Rear)

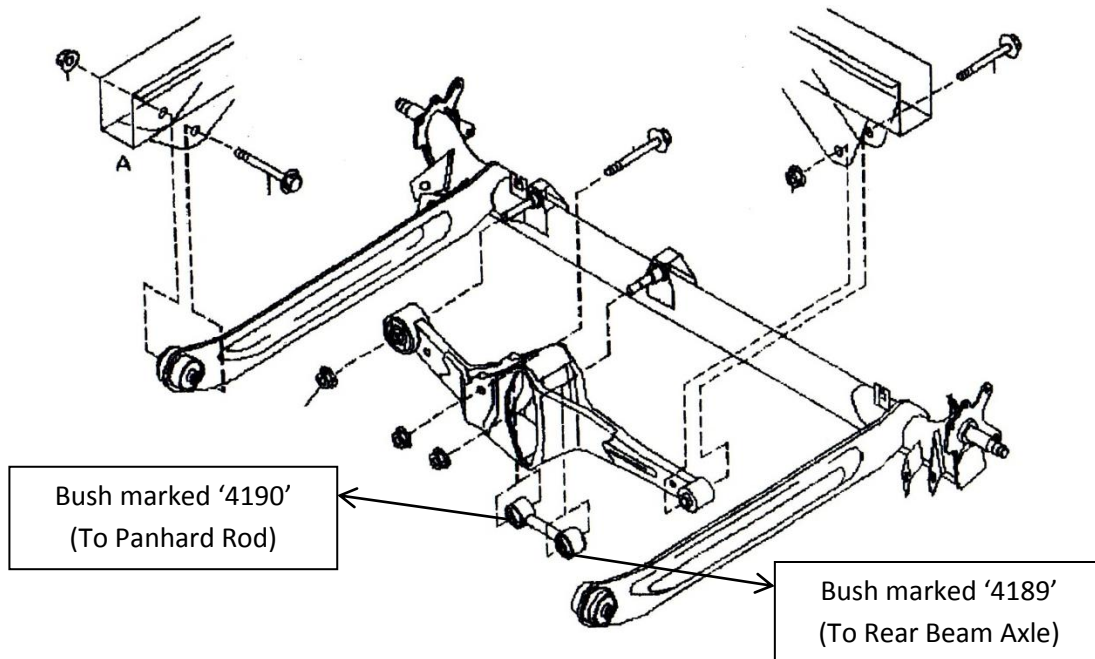

- Jack the vehicle and place on floor stands or raise on a two-post hoist;
- Remove the rear suspension link from the vehicle;
- Remove original bushings of the rear suspension link with the use of a hydraulic press and suitable pressing tools;
- Clean housing areas to remove any old original bushing materials before installing new bushes;
- Lubricate the body of the new polyurethane bushes and press into the rear suspension link with reference to the diagram above for position;
Note: bush marked '4189' has bigger OD compared to '4190'. Make sure that you fit the bushes into the correct housing (see diagram above), cross check with a vernier caliper or ruler prior to installation.
- Next, generously lubricate the outside of the steel crush tube, the bore of the new bush and then, push the crush tube in. Note: 40mm long crush tube goes with '4189' bush, and 45mm long crush tube goes with '4190' bush.
- Refit the suspension link to the vehicle and ensure that all fasteners are torque to manufacturer's specification.