

# Fitting Instructions #3256IS

## Mazda MX5 / RX8

### Front Lower Control Arm Rear Bushing (To suit Right-hand drive vehicles)

**Note:** Polyurethane bushes must be fitted to both sides of the vehicle.

- Wheel align the vehicle before the job is started and note castor settings;
- Following manufacturer's recommendations, remove the front lower control arms from the vehicle;
- Remove original shell part and/or front factory rubber bushing from the control arms with the use of a hydraulic press and suitable pressing tools;
- 1 ○ Clean housing areas to remove any old original bushing materials;
- For the front bush: lubricate the body of the bushes and push them into the arm. Next, lubricate the bore of the new bushes and the outside of the steel crush tube. Then, use an arbour press to push the steel crush tube into the bushes (See Figure 1 below);
- For the rear bush: Using the appropriate pressing tools support the control arm and press in the new bushes with reference to Table 1 below so that the offset rear bush is positioned to give the desired castor result;
- Using the grease supplied, generously lubricate the outside of the steel crush tube and the inside of the new polyurethane shell parts. Then, push the steel crush tubes into the new bushings, a hand press may be required to insert the steel tube, as there can be significant crush;

- Grease the faces of the spacer washers, and push them onto the tubes. The spacers are to be arranged as depicted in Figure 2 below. (Larger face of spacers must face the new bushing)
- Lubricate the side faces of the new bushings and the areas on the chassis that contact the new bushings and refit the front lower control arm.
- Tighten all fasteners to manufacturer's specifications with the vehicle at ride height, get the vehicle wheel align and check new settings.

Left Hand Side Shown

Front of Vehicle

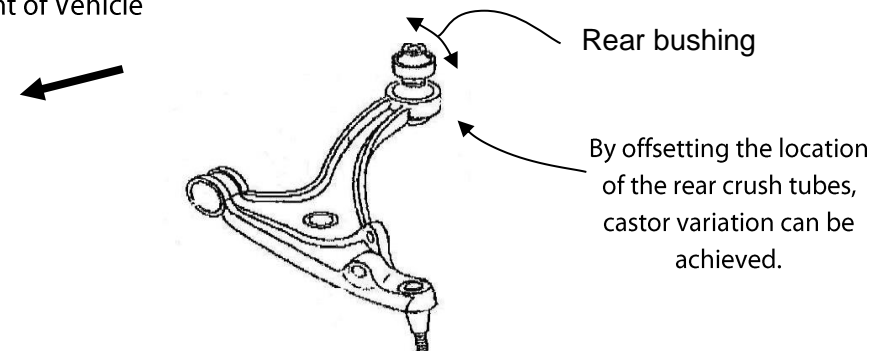
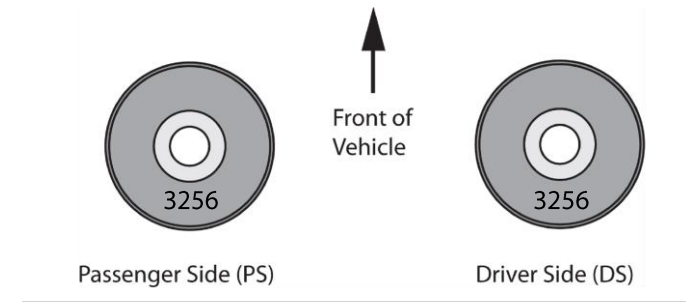

**Figure 1**

# Fitting Instructions #3256IS

As viewed from the top of the control arm, looking down on rear bushing.

**Kit #3477K** – Standard Replacement, no castor change



**Kit #3487K** – To counteract a slight pull to the left  
Single Offset, Passenger side castor Increase (Right Hand Drive Vehicle)

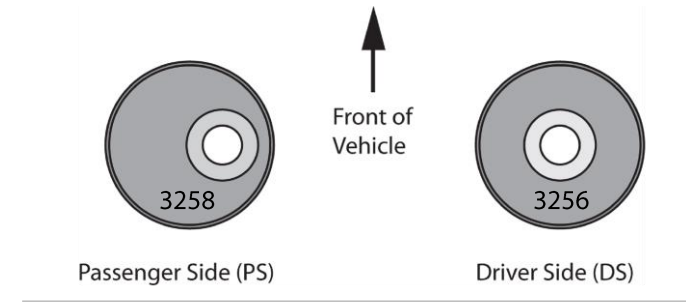

**Kit #3478K** – Performance settings  
Double Offset, Increase castor both sides

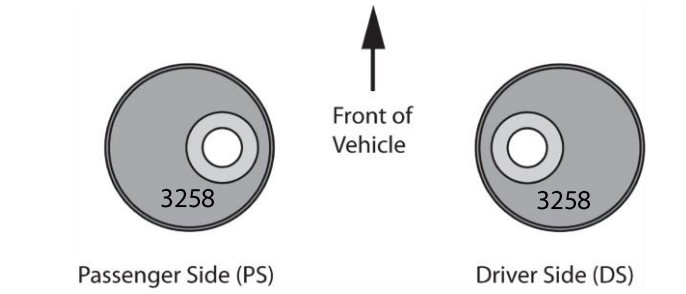

**Table 1:** Illustration of Castor Settings

Side view of assembled new part in control arm

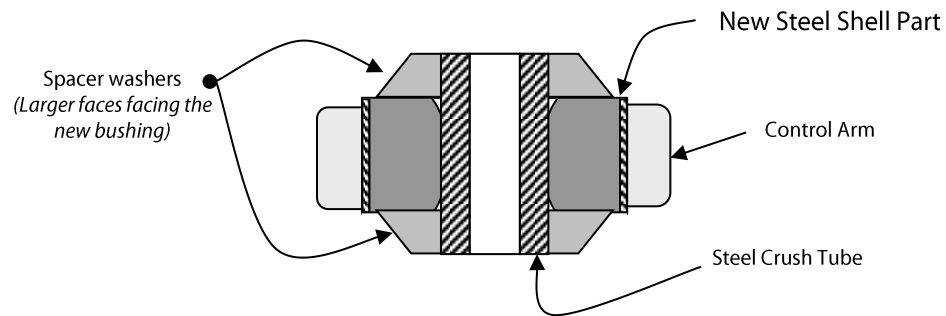

**Note** the orientation of the Spacer Washers.

**Figure 2:** Spacers Arrangement.