

Fitting Instructions #3111IS

Mitsubishi Outlander / Mitsubishi Lancer

Front Lower Control Arm Inner Rear Bushing (To Suit Right-Hand Drive Vehicles)

Note: Polyurethane bushings must be fitted to both sides of the vehicle.

- Wheel-align the vehicle before the job is started and note settings;
 - With the vehicle on jack stands/hoist remove the front wheels and remove the lower control arms;
 - Remove original shell part from the housing with the use of a hydraulic press and suitable pressing tools, take care to prevent stretching arm;
 - With reference to the diagrams and the settings required, align the bushing with the bracket so that the hole in the bush is positioned to give the desired result.
 - Press the bushes into the housings;
 - The crush tubes can now be fitted to the bushes. A generous amount of the white grease supplied must be applied to both the bore of the bush and the outside of the crush tube.
- Fit the spacers supplied over the crush tubes top and bottom, use the white grease supplied to lubricate the spacers;
 - Refit the control arms;
 - Wheel-align vehicle and check new settings;
 - All mounting bolts are to be torqued to manufactures specifications.

Left hand side shown

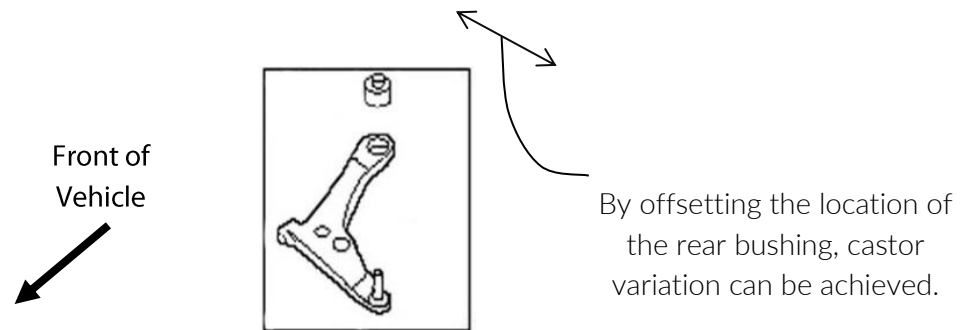

Fitting Instructions #3111IS

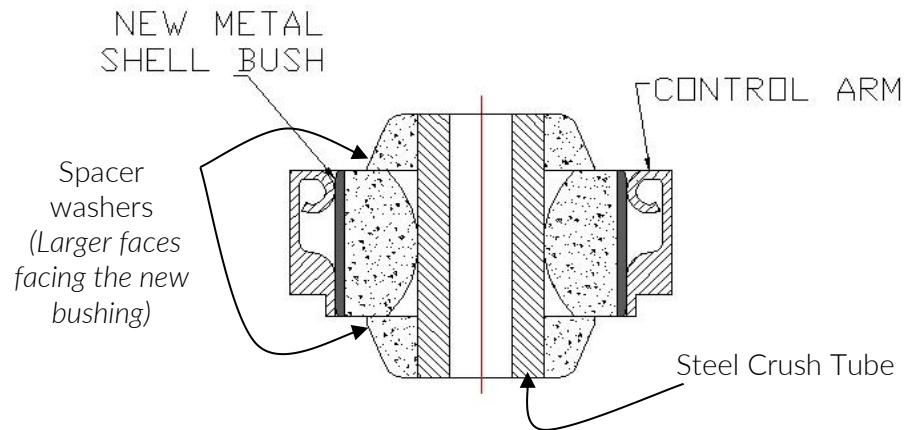

Note the orientation of the Spacer Washers.

As viewed from the top of the control arm.

Kit #3111K – Standard Replacement. No castor change.

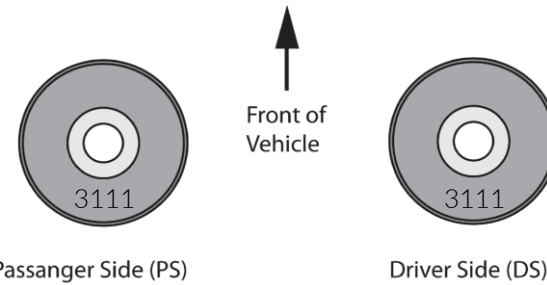

Kit #3112K – To counteract a slight pull to the left
Single Offset, Passanger side castor increase (+0.5 degree).

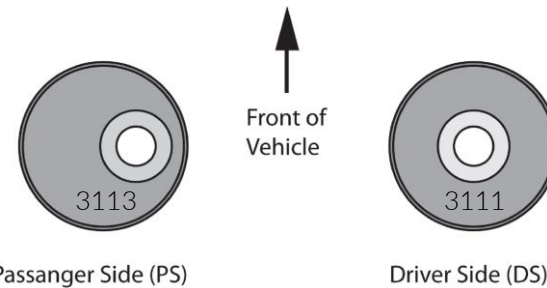

Kit #3113K – To counteract a strong pull left
Double Offset, passanger +0.5 degree and driver -0.5 degree castor.

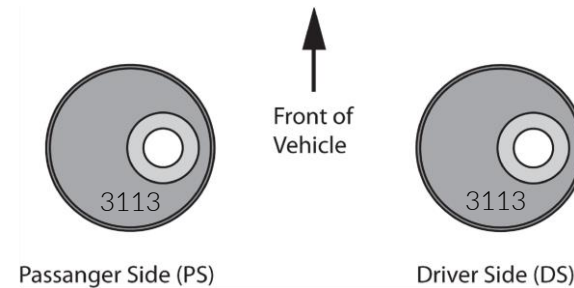

Table 1: Illustration of Castor Settings