

Fitting Instructions #TRC481IS

Toyota Landcruiser Prado 120 series

Front Camber Lower Control Arm standard and offset



As viewed from the rear of Right Hand Side	
TRC481K - Standard	TRC482K - Negative Camber Increased for Raised Vehicles
	 Gives 0.6 degree camber change with maximum offset

NOTE: These components must be fitted by qualified persons only, to factory specifications, as per factory service manual. Photos are indication and may vary slightly in appearance from actual product

1. Before beginning any alignment work, always check for loose or worn parts, proper tyre pressures, and odd tyre wear patterns. Replace any loose or worn parts before setting alignment;
2. Raise vehicle by the chassis and support with jack stands. Remove front tyre and wheel assemblies;
3. Remove the factory front lower control arms and clean the chassis area.
4. Install the control arms to the vehicle;



5. Use the supplied camber pins, shank coated with anti-seize, to tighten the arm onto the chassis (see camber bolt diagram for correct installation) but reuse the factory bolt for the ball joint bracket;
6. Re-install the tyre and wheel assembly. Lower the vehicle and take alignment readings. Adjust the camber pins to achieve the desired setting;
7. When final caster/camber settings are achieved, torque the camber pins assembly to 140 Nm and road test the vehicle.

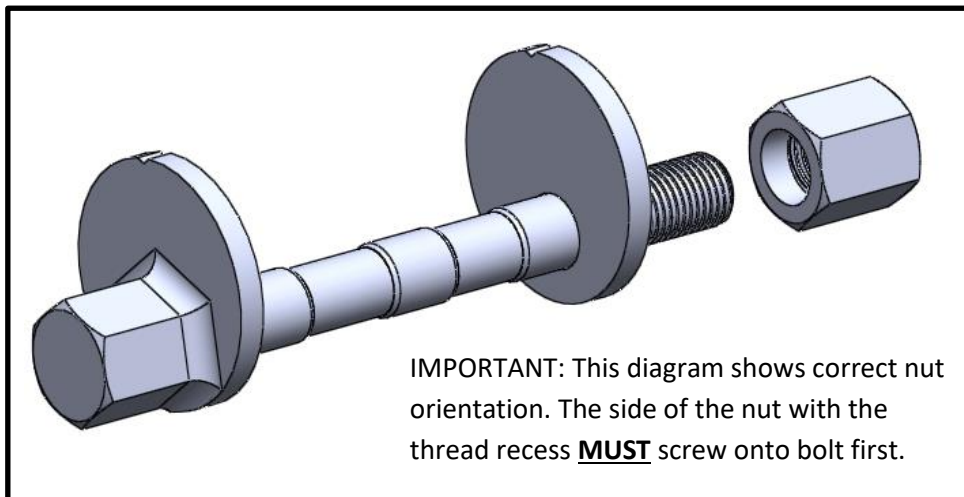

IMPORTANT: This diagram shows correct nut orientation. The side of the nut with the thread recess **MUST** screw onto bolt first.

Camber Bolt installation diagram