

Fitting Instructions #TRC497IS

Toyota Prado 150 series

Rear Adjustable Lower Trailing Arm

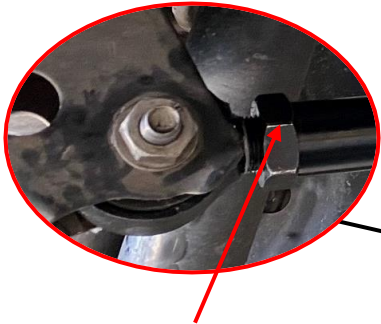

IMPORTANT: Adjustable side (Rod End) of the Lower Arm **MUST** be installed on Differential side.

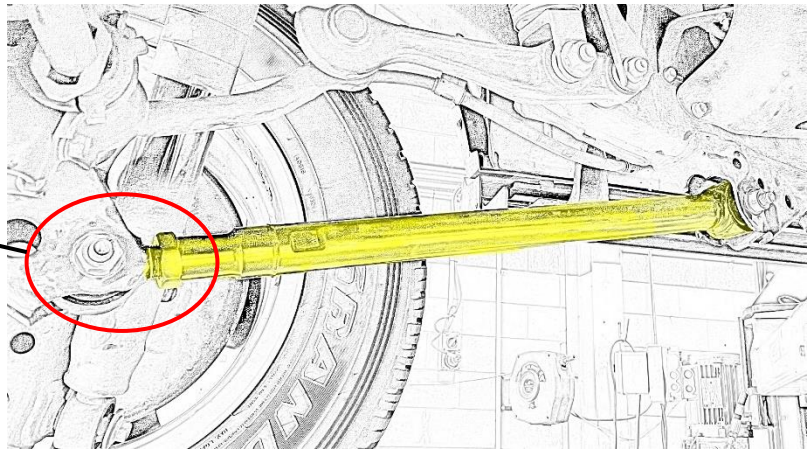

NOTE: These components must be fitted by qualified persons only, to factory specifications, as per factory service manual. Photos are an indication and may vary slightly in appearance from actual product

1. With the vehicle at ride height, measure and record the angle of the output shaft face of the transfer case and the input shaft face on the differential. Measure difference in angle and calculate the required arm length for faces to be parallel. Refer to diagram on page 2.

Note: the shaft face on the differential must be parallel to the transfer case face (or as near as possible).

2. Raise vehicle by the chassis and support on hoist.
3. Support the rear diff with long adjustable stands/under hoist stands;
4. Remove the factory Rear Lower Trailing Arm and clean the chassis area.
5. Apply the grease supplied on all bushing contact areas;
6. Set the new rear adjustable control arm to the desired length (based on the difference in angle recorded earlier). **Note:**
 - a. If pairing with TRC498 (Rear Upper Adjustable Trailing Arm), Set length initially to OE length, then adjust both Upper and Lower Control arms to centre the differential in the rear wheel arch, then adjust lengths to correct pinion angle (refer diagram on page 2).
7. Install the new Rear Lower Trailing Arm to the vehicle. *Ensure to tighten the lock nut once the desired length is achieved.*

Note: Adjustable side (Rod End) of the Lower Arm **MUST** be installed on Differential side.

8. Lower the vehicle to ride height and double check the pinion angle, readjust as required.
9. Manufacturer's torque setting must be used on all bolts.
10. Recheck all bolts after 1000km or 1 month;

Fitting Instructions #TRC497IS

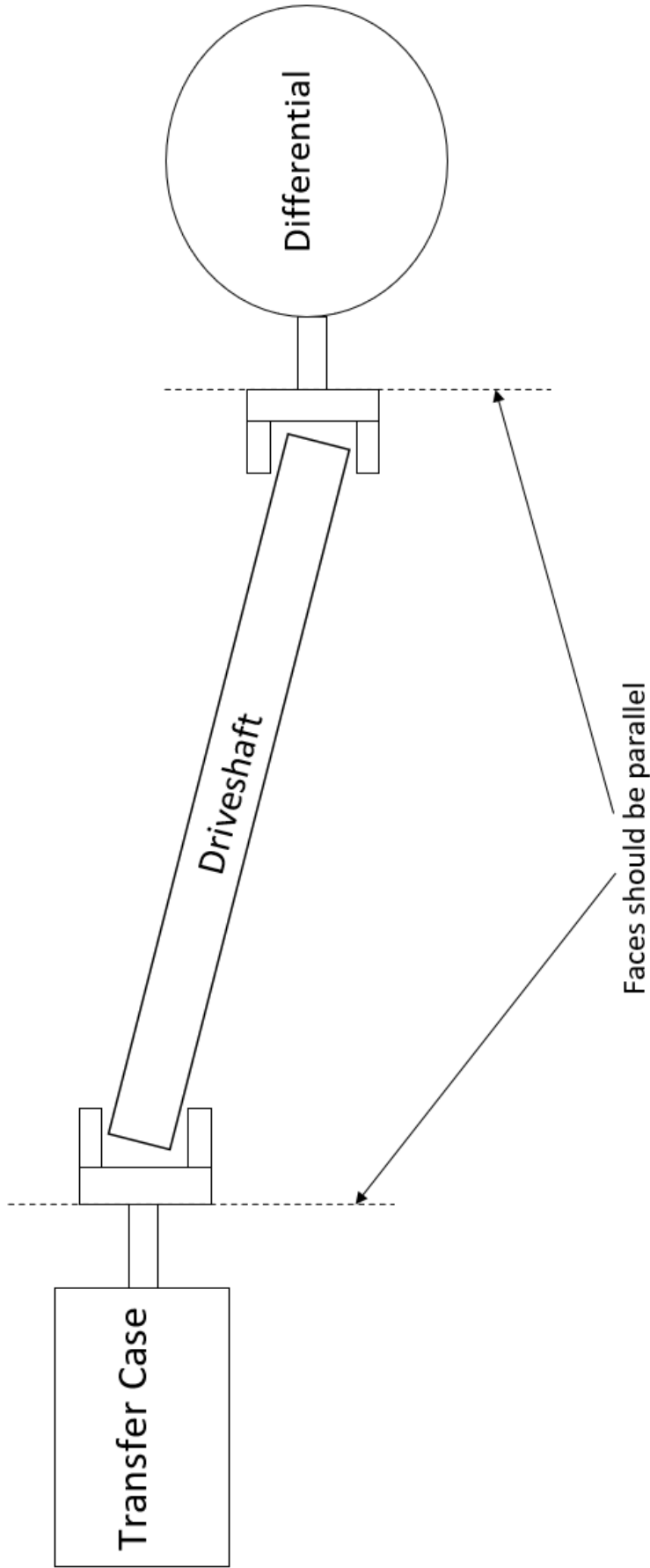

To correct pinion angle, use an inclinometer to measure the difference in angle between the faces on the transfer case and the differential and adjust the trailing arms as required until difference in angle is 0 degrees.

For example: Angle of transfer case face from level: 86°

Angle of differential face from level: 83°

Difference in angle = $86 - 83$

= 3°