

Fitting Instructions #3424IS

Honda Civic "TYPE R" 8th Generation

Front Lower Control Arm Inner Front Bushing

Note: Polyurethane bushings must be fitted to both sides of the vehicle.

- Wheel-align the vehicle before the job is started and note settings;
- Jack the vehicle up and support on jack stands;
- Remove the lower control arms;
- Remove original shell part from the housing with the use of a hydraulic press and suitable pressing tools;
- With reference to the diagrams and the settings required, align the bushing with the bracket so that the hole in the bushing is positioned to give the desired result;
- Apply the white grease supplied to the bore of the bush, the outside of the crush tube and the inside of the polyurethane spacers;
- Push in the crush tube and fit the polyurethane spacers;
- Refit the control arm to the vehicle. Tighten all bolts to manufactures torque settings;
- Carry out a wheel alignment.

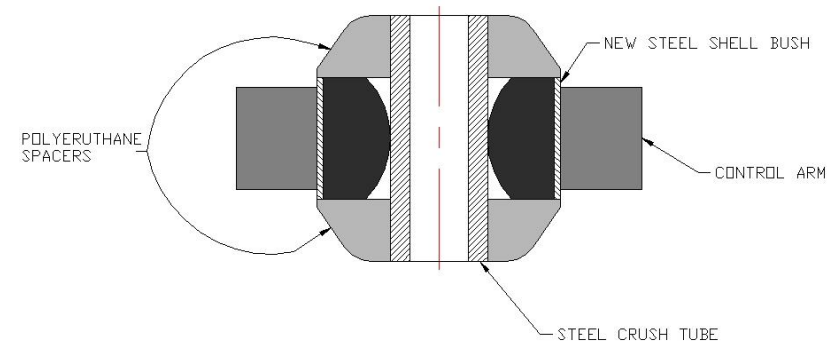
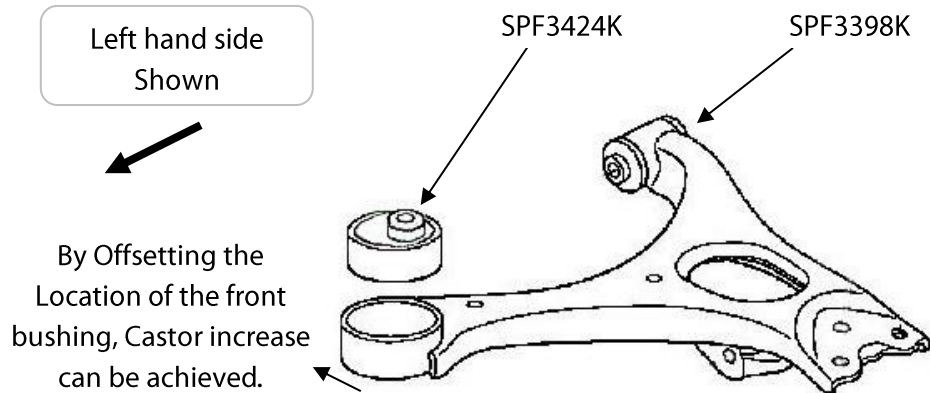

As viewed from the top of the control arm.

Kit #2306FK – Standard Replacement. No castor change.

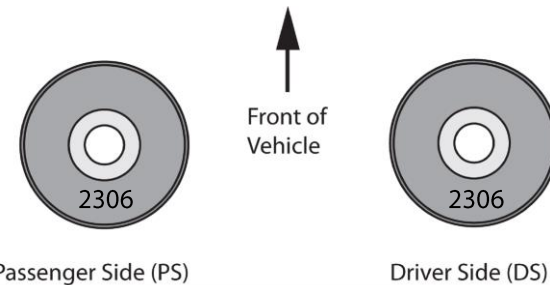

Kit #3424K – Performance Settings.
Castor Increase both sides.

