

# Fitting Instructions #1799IS

## Nissan Various Models

### Rear Cross-member Supplement Washers

**Note:** Polyurethane bushings must be fitted to both sides of the vehicle. Manufactures torque settings must be used on all bolts.

- The washers are used to preload the sub frame mounts and removing the excessive compliance. By following the instructions and locating the washers in different positions varies settings can be achieved;
- With the vehicle resting on its wheels, ideally on a drive or hoist, loosen two sub-frame to chassis mount nuts on one side only;
- Support the sub-frame using a jack, remove the nuts and lower the sub-frame;
- Fit polyurethane washers in the desired positions according to the figure;
- Raise the sub-frame and refit mounting nuts;
- Repeat above steps on the other side of the vehicle;
- Tighten all sub-frame mounting nuts. All mounting bolts are to be tightened to manufactures specifications with the vehicle at ride height.

*Note: When fitting bushes above the sub frame, the technician can opt to cut the bush axially for ease of fitment.*

As viewed from the side of the vehicle

#### Performance Setting

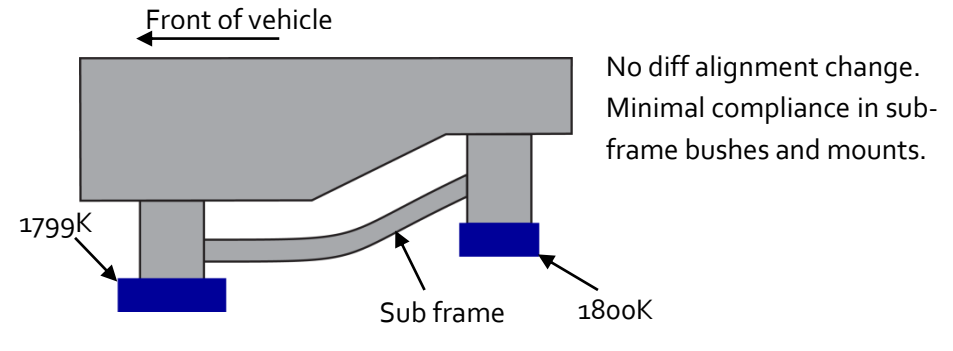

#### Traction Setting

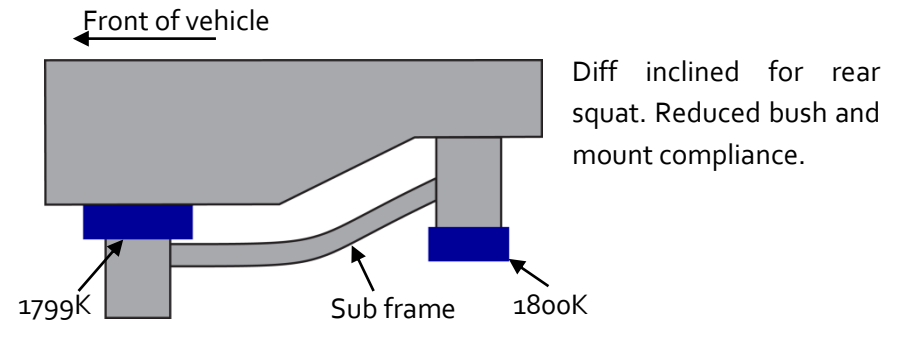

#### Drift Setting

