

Fitting Instructions #1610IS

Ford Mondeo HC, HD, HE

Control Arm Lower Rear Bushing



Note: In some applications a thin steel insert is used inside the original crush tube. This insert must be removed before attempting to remove the arm from the vehicle. During installation the insert should be re-installed into new steel tubes.

- Use a hydraulic press to remove the OE bushes from the arms, and replace with the supplied steel shell parts;
- Using the grease supplied, generously lubricate the outside of the steel tube, the polyurethane inside of the steel shell parts, and the inside of the spacer washers;
- Push the steel crush tubes into the bushes. An Arbour press may be required to insert the steel tube, as there can be significant crush;
- Grease the faces of the spacer washers, and push them onto the tube. The spacers are to be arranged as depicted in the following diagram.

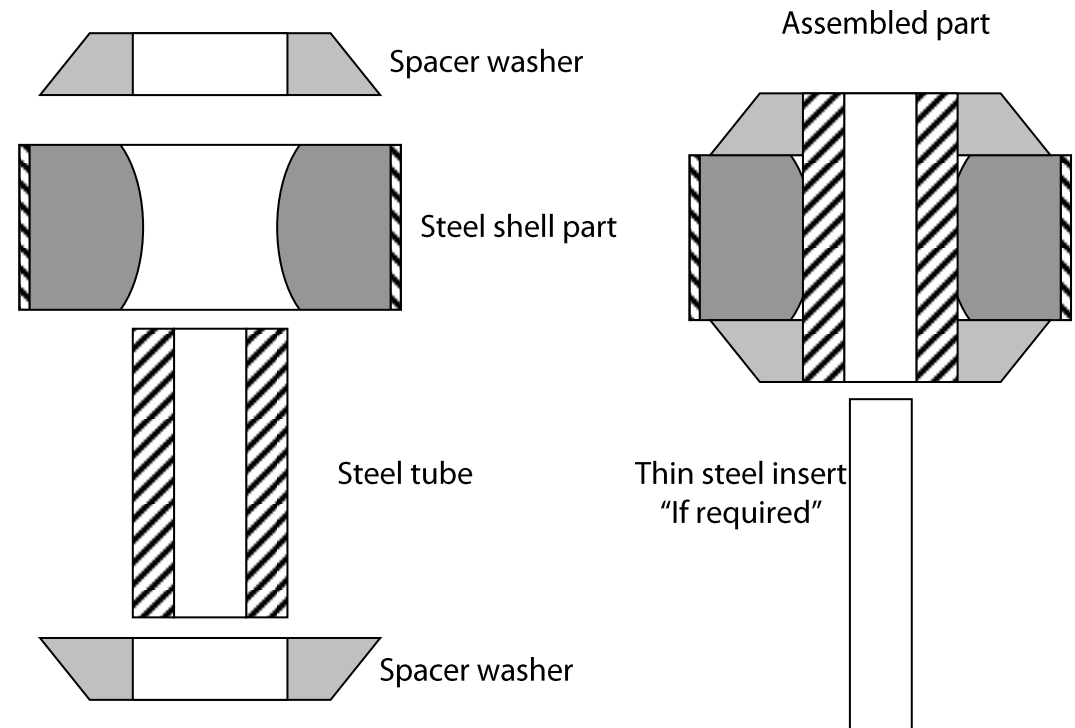

▫ *Note the orientation of the Spacer*