

Fitting Instructions #3952IS

BMW 1 SERIES E81, E82, E87 & E88 / BMW 3 SERIES E90, E91, E92 & E93

Rear Lower Control Arm Inner Bushing

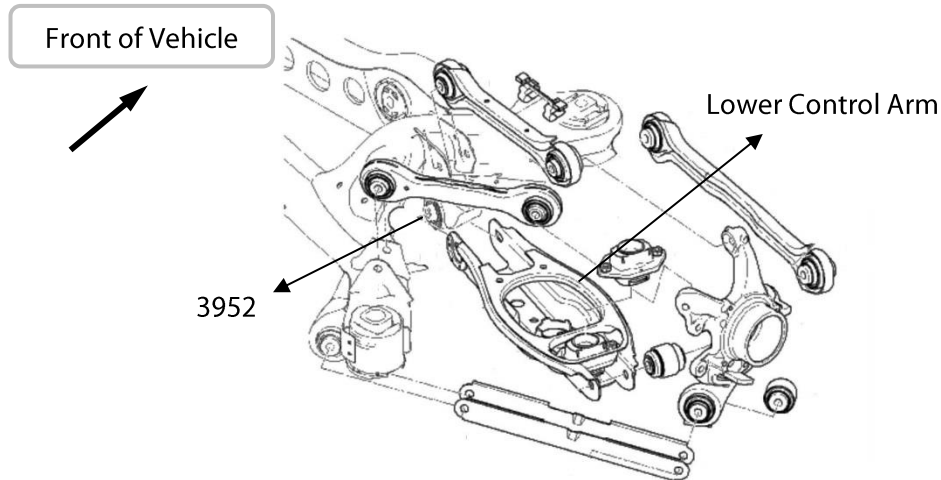

Note: Polyurethane bushes must be fitted to both sides of the vehicle.

- Following manufacturers recommendations remove rear lower control arms from the vehicle;
- The rear lower control arm bush is located in the subframe. To remove, you will need the following items (Refer to Figure 1): 1 x threaded rod and 2 matching nuts, (A) 1 x metal spacer where it's OD is slightly smaller than the ID/bore of the Diff mount housing, (B) 1 x metal spacer where it's ID is slightly bigger than the ID/bore of the Diff mount housing, (C) heavy gauge washers one to sit outside on each of the metal spacer, (D) old pinion style bearing, 2 matching spanners;

- Set the tools up according to the figure below and draw the bushes out;

Note: excessive force is not necessary, make sure the metal spacers are lined up correctly. Also cover the bearing with a rag in case of failure, appropriate safety equipment must be used;

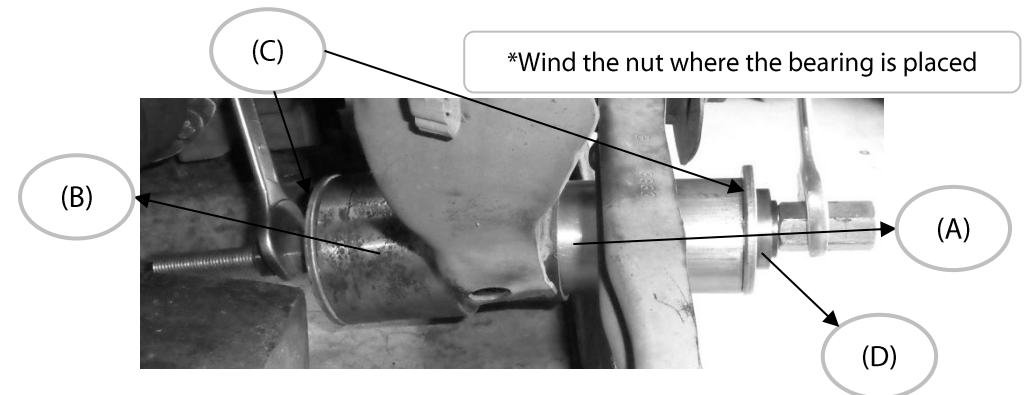

Fitting Instructions #3952IS

- Clean housing areas to remove any old original bushing materials before installing new bushes. Apply the grease supplied to the housing and the outside of the bush, then push the new bushes in (As shown in the diagram below);

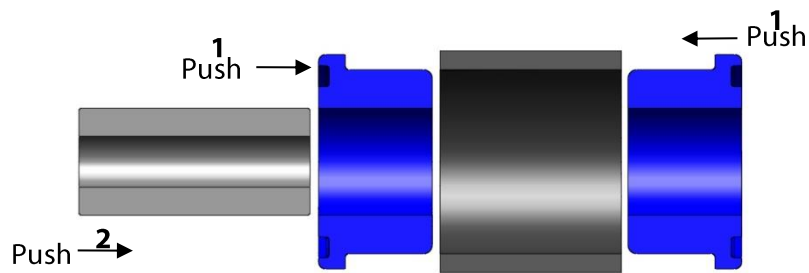

- To fit the crush tube into the bushes, apply the grease supplied to the bore of the bush and the outside of the crush tube. Then, push it in;

- Repeat process to install the rest of the bush;
- Refit the control arms into the vehicle. Tighten all fasteners to the manufacturer's specifications with the vehicle at ride height and get the vehicle wheel-aligned.

Note: use a pair of multi grips to aid installation if necessary.